

1/2 In-Hole Photocell

MS-PUNVC01



Features

- AC input voltage range: 90~305V.
- Low power consumption and high reliability.
- 8-15S delay when turn off.
- Strong anti-interference ability.
- Maximum working load: 750W filament lamps.
120Vac, 5A electronic ballast.
277Vac, 3A electronic ballast.
- Switch life is greater than 5000 cycles.
- Approved application patent.
- Suitable for dry and humid environment.



Product Description

The MS-PUNVC01 1/2 in-hole photocell is suitable for roadway light, advertising light boxes, signs and other equipment used in various places such as roads, outdoor lighting, building corridors, and park district lighting. Reliable function and high sensitivity. This product has a wide voltage range to meet the voltage requirements of each region. In addition, the preset 8-15 second delay prevents malfunctions caused by lightning, flashlights, car taillights, etc. at night. This product has passed UL certification and complies with UL773A standard for non-industrial light control switches.

Product Parameters

Model No	MS-PUNVC01
Voltage Rating	90~305Vac (Certificated Input range: 100~277Vac)
Rated Frequency	50/60Hz
Switch Illumination	10~20Lx when turn on, 60~80Lx when turn off
Maximum Load	750W filament lamp 120 Vac, 5 A electronic ballast/LED 277 Vac, 3 A electronic ballast/LED
Power Consumption	0.7W
Ambient Temperature	-40°F ~ 176°F
Ambient Humidity	≤99%RH
Net Weight	40g±2g
Product Size	2.36"(L) x 1.41"(W) x 1.79"(H)
Wire Length	7.09" (180mm) also customizable (AWG#18)

Installation Instruction

- Disconnect power before installation.
- Drill a 0.67" (17mm) diameter hole on the side of the luminaire with a hammer or punch.
- Unscrew the nut from the photocell.
- Pass the threaded portion of the photocell through the drilled hole.
- Screw the nut and secure it in right place.
- Wire the photocell according to the wiring diagram

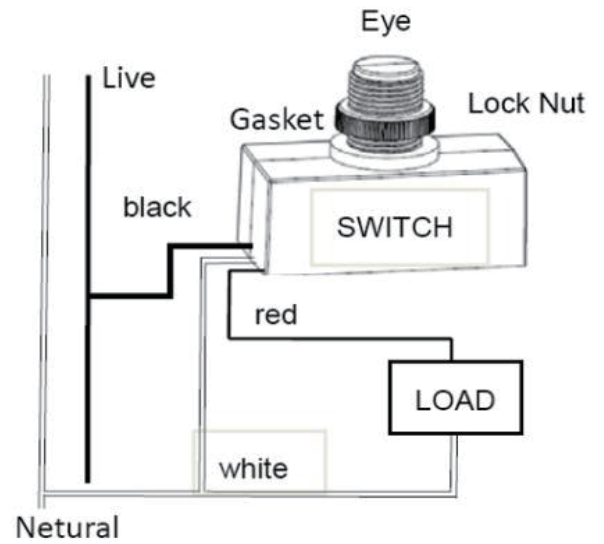

Structure Dimensions (inches-mm)

