

LED SPEC-SELECT™ DESIGNER STRIP

INSTALL INSTRUCTIONS

PLEASE FIND A QUALIFIED ELECTRICIAN FOR INSTALLATION. Please read the instructions before you install and use the luminaire. WARNINGS, CAUTIONS AND OPERATING INSTRUCTIONS

- To reduce the risk of death, personal injury or property damage from fire, electric shock, falling parts, cuts/abrasions, and other hazards read all warnings and instructions included with and on the fixture box and all fixture labels.
- Before installing, servicing, or performing routine maintenance upon this equipment, follow these general precautions.
- Commercial installation, service and maintenance of luminaires should be performed by a qualified licensed electrician.
- For the installation: If you are unsure about the installation or maintenance of the luminaires, consult a qualified licensed electrician and check your local electrical code.
- To prevent wiring damage or abrasion, do not expose wiring to edges of sheet metal or other sharp objects.
- Do not make or alter any open holes in an enclosure of wiring or electrical components during kit installation.

WARNING: RISK OF FIRE OR ELECTRICAL SHOCK

- Turn off electrical power at fuse or circuit breaker box before wiring fixture to the power supply.
- Turn off the power when you perform any maintenance.
- Verify that supply voltage is correct by comparing it with the luminaire label information.
- All wiring connections should be capped with UL approved wire connectors.

CAUTION: RISK OF INJURY

- Avoid direct eye exposure to the light source while it is on.
- Account for small parts and discard packing material, as these may be hazardous to children.
- Risk of burn. Disconnect power and allow fixture to cool before handling fixture.
- Green ground screw provided in proper location. DO NOT RELOCATE.
- Use minimum 194°F supply conductors.
- Suitable for Dry or Damp locations.

WARNING - TURN OFF POWER SUPPLY FROM MAIN CIRCUIT BREAKER BEFORE INSTALLING OR SERVICING.

GENERAL WIRING DIAGRAM

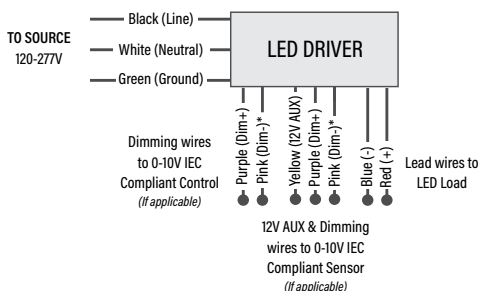

**Per NEMA rule-change Dim (-) control wires changed from gray to pink after Jan. 01, 2022.*

Note: If not connecting to an external 0-10V dimmer circuit, make sure fixture's 0-10V pink and purple leads are capped off separately. Failure to do so may cause fixture to perform incorrectly, and void warranty.

FIELD ADJUSTABLE WATTAGE & CCT

The end users may adjust the color temperature and lumen output, respectively, by the two slide switches integrated into the driver. Each switch has 3 options (left, middle and right), each position corresponds to 3 color temperatures (3500K, 4100K, and 5000K) and 3 wattages, which can be adjusted to the desired combination.

1. Switches are located on the driver.
2. Select a wattage and color temperature by sliding switch left or right respectively to the desired value.

Check to make sure the luminous part is snapped back into place. Gently pull down on the luminous part to ensure it is securely attached and does not shift.

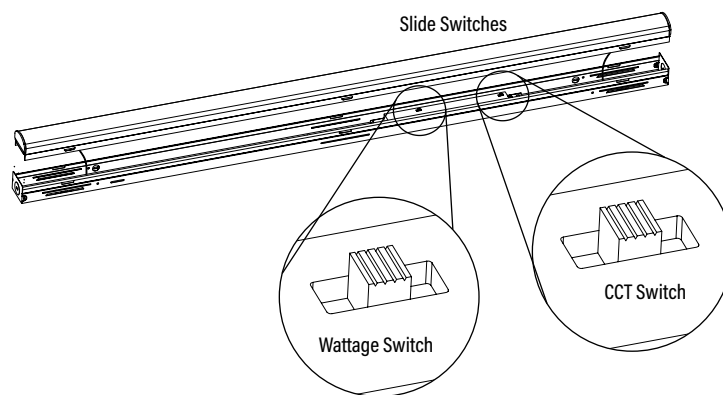

LED SPEC-SELECT™ DESIGNER STRIP

INSTALL INSTRUCTIONS

WARNING - TURN OFF POWER SUPPLY FROM MAIN CIRCUIT BREAKER BEFORE INSTALLING OR SERVICING.

SURFACE MOUNT INSTALLATION

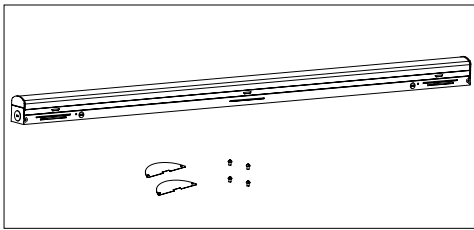

1. Remove fixture and accessory kit from the package.

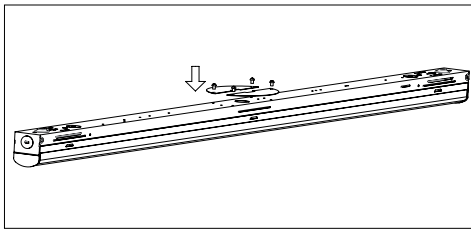

2. Attach baffle to the back of the fixture.

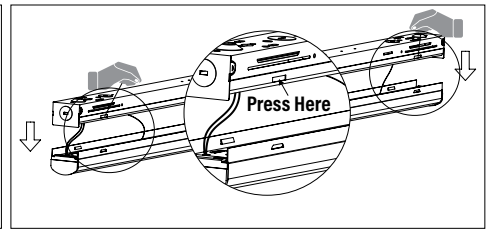

3. To open the fixture, press the areas between the narrow strip-type hole and snap-locks, to detach the snap-locks that hold the lens & led assembly, and gently lower the assembly.

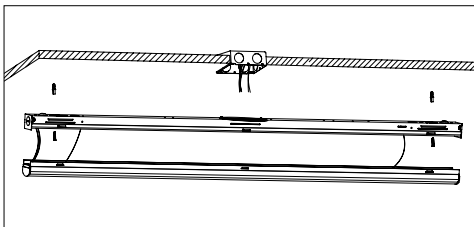

4. Pull AC wires and dimming wires (if applicable) through the outlet hole, then secure the luminaire to the ceiling with anchors and screws (not included).

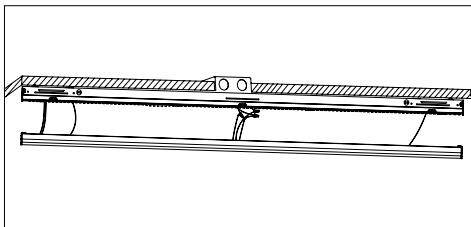

5. Use appropriate UL approved wire connectors as required by code to complete connection with main power and dimming wires. *NOTE: If needed, dimming wires must be connected to 0-10V control circuit.*

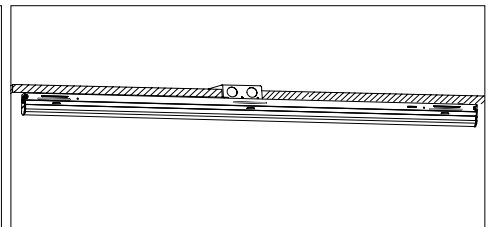

6. Reattach the luminous part upwards and make sure it is securely locked into place. Inspect lens*. The installation is complete.

CHAIN SUSPENDED INSTALLATION (V-Hooks and Chain sold separately)

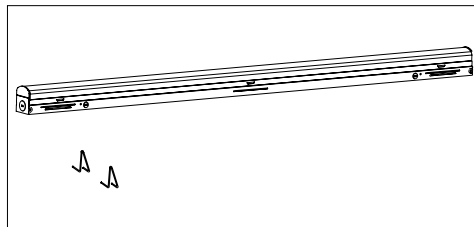

1. Remove fixture from the package.

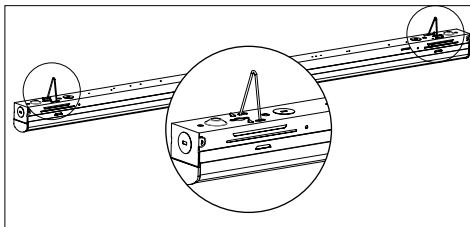

2. Connect V-hooks to the back of the fixture.

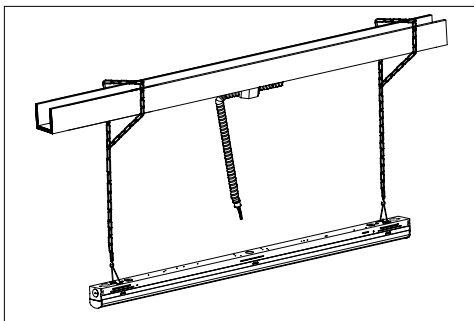

3. Attach chain to the V-hooks to hang the luminaire.

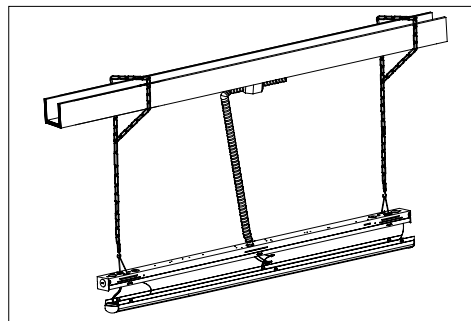

4. Attach the end of pipe to the outlet hole. Open the fixture body and connect the AC wires and dimming wires. *NOTE: If needed, dimming wires must be connected to 0-10V control circuit.*

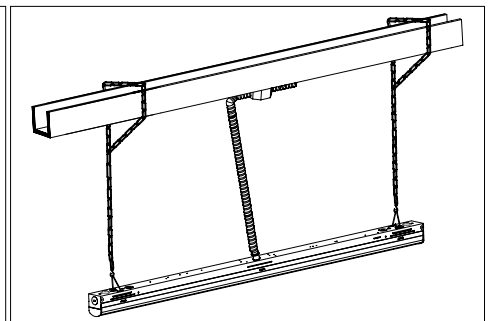

5. Reattach the luminous part to the housing. Inspect lens* to complete the installation.

INSPECTION After installation check to make sure the luminous part is snapped back into place. Gently pull down on the luminous part to ensure it is securely attached and does not shift.

LED SPEC-SELECT™ DESIGNER STRIP

INSTALL INSTRUCTIONS

! WARNING - TURN OFF POWER SUPPLY FROM MAIN CIRCUIT BREAKER BEFORE INSTALLING OR SERVICING.

CABLE SUSPENDED INSTALLATION (V-Hooks and Cable sold separately)

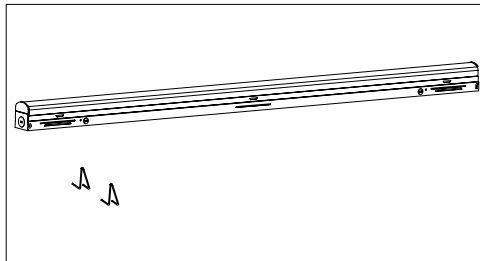

1. Remove fixture from the package.

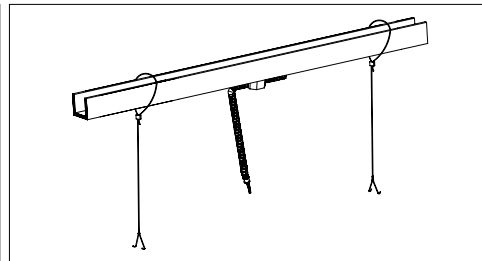

2. Connect V-hooks to cables.

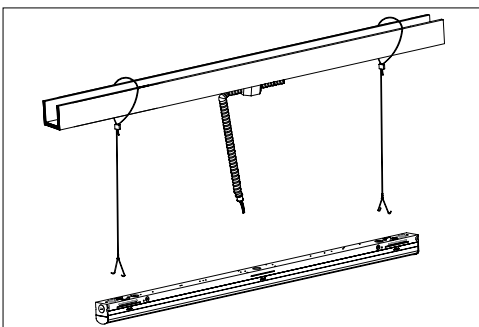

3. Attach V-hooks to fixture body to hang the luminaire.

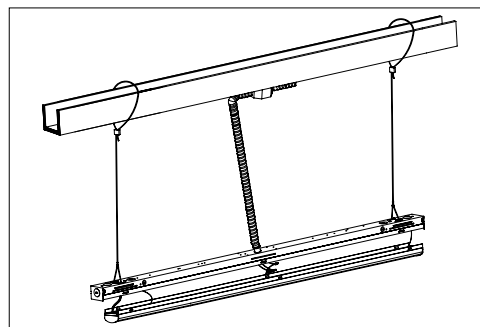

4. Attach the end of pipe to the outlet hole. Open the fixture body and connect the AC wires and dimming wires. *NOTE: If needed, dimming wires must be connected to 0-10V control circuit.*

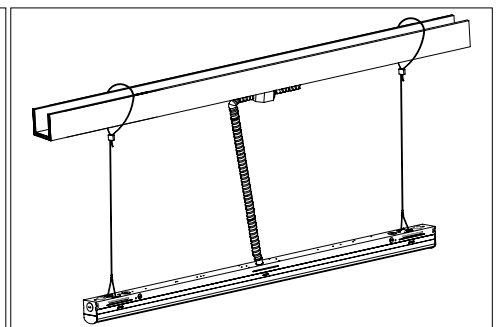

5. Reattach the luminous part to the housing. Inspect lens* to complete the installation.

INSPECTION After installation check to make sure the luminous part is snapped back into place. Gently pull down on the luminous part to ensure it is securely attached and does not shift.

FIXTURES W/ISO - INTEGRATED SENSOR OPTION

(If applicable, sensor and elbow sold separately)

For fixtures, with an integrated sensor socket.

1. Remove sensor socket cover. (Fig. 1)
2. Install elbow connector by screwing in clockwise until firmly seated. Once firmly installed, elbow socket can be carefully adjusted to desired position. (Fig. 2)
3. Install sensor by screwing in clockwise until firmly seated. (Fig. 3 & 4)

Note: If you move the sensor to a different location on the fixture, use knockout plug to cover original sensor hole.

