

# LED BACK-LIT PANELS

## INSTALL INSTRUCTIONS

**PLEASE FIND A QUALIFIED ELECTRICIAN FOR INSTALLATION.** Please read the instructions before you install and use the luminaire.

### WARNING, CAUTIONS AND OPERATING INSTRUCTIONS

- Make all electrical and grounded connections in accordance with the National Electrical Code and any applicable local code requirements.
- To reduce the risk of death, personal injury or property damage from fire, electric shock, falling parts, cuts/abrasions, and other hazards read all warnings and instructions included with and on the fixture box and all fixture labels.
- Before installing, servicing, or performing routine maintenance upon this equipment, follow these general precautions.
- Commercial installation, service and maintenance of luminaires should be performed by a qualified licensed electrician.
- For the installation: If you are unsure about the installation or maintenance of the luminaires, consult a qualified licensed electrician and check your local electrical code.
- To prevent wiring damage or abrasion, do not expose wiring to edges of sheet metal or other sharp objects.
- Do not make or alter any open holes in an enclosure of wiring or electrical components during kit installation.

### WARNING: RISK OF FIRE OR ELECTRICAL SHOCK

- Turn off electrical power at fuse or circuit breaker box before wiring fixture to the power supply.
- Turn off the power when you perform any maintenance.
- Verify that supply voltage is correct by comparing it with the luminaire label information.
- All wiring connections should be capped with UL approved wire connectors.

### CAUTION: RISK OF INJURY

- Avoid direct eye exposure to the un-louvered light source while it is on.
- Account for small parts and destroy packing material, as these may be hazardous to children.
- Risk of burn. Disconnect power and allow fixture to cool before changing bulb or handing fixture.
- Do not relocate Green ground screw provided, it is in the proper location.
- Minimum 194°F supply connectors.
- Suitable for Dry or Damp locations, Type IC

**! WARNING - TURN OFF POWER SUPPLY FROM MAIN CIRCUIT BREAKER BEFORE INSTALLING OR SERVICING.**

### RECESSED MOUNTING

1. Carefully unpack the unit and properly inspect for defects before installing. Wear work gloves to prevent dirt and oil from being transferred to the luminaire. If cleaning is needed, use gloves and a dry cloth. It is not recommended to use hazardous chemicals. (Fig. 1)
2. Lift up the four mounting clips on the sides of the luminaire. If done by hand, use gloves, or use pliers (Fig. 2).
3. Insert luminaire into T-bar ceiling grid. Secure safety cable to connection hole as needed to meet local seismic requirements. Safety cable and method of attachment to the building provided by contractor according to local building codes. (Fig. 3)

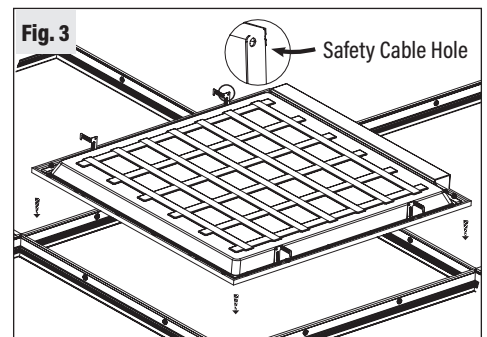
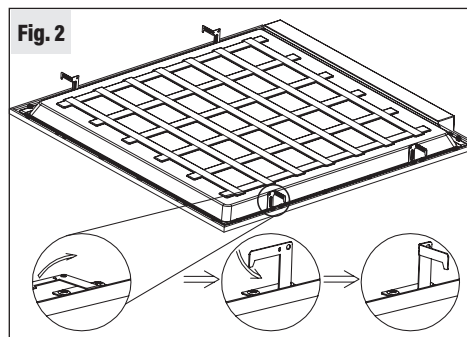
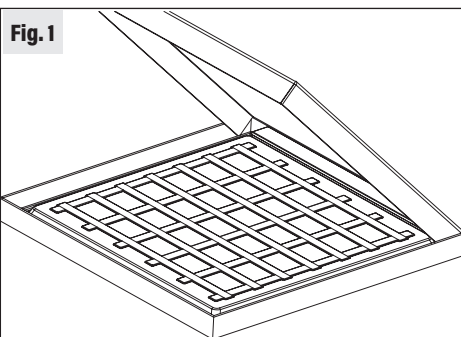

# LED BACK-LIT PANELS

## INSTALL INSTRUCTIONS

**WARNING** - TURN OFF POWER SUPPLY FROM MAIN CIRCUIT BREAKER BEFORE INSTALLING OR SERVICING.

### RECESSED MOUNTING (Cont'd)

4. Remove electrical enclosure cover. Carefully remove the knockout for AC line input wires (and 0-10V control line if needed). Install UL-listed electrical fittings in the knockout holes for wire protection if needed. (Fig. 4)
5. Plug in AC line (L, N, and GND) to the LED Driver using 18-14AWG Wire. When connecting 0-10V dimming controller, wires must run through a separate knockout hole equipped with an appropriate electrical fitting. (Fig. 5)
6. Follow wire connection instructions (Fig. 6). When using the 0-10V dimming controller, run wires from controller through a different knockout than the AC input wire. Do not forget to return the electrical enclosure cover and tighten the screws.

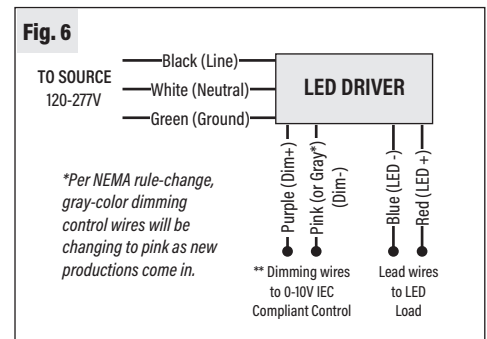
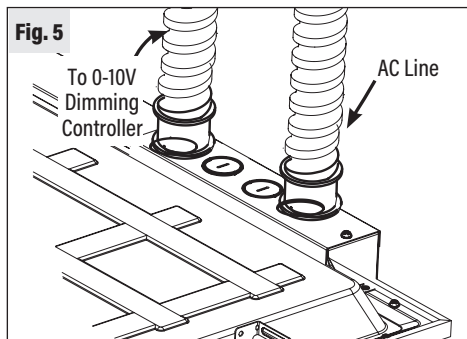
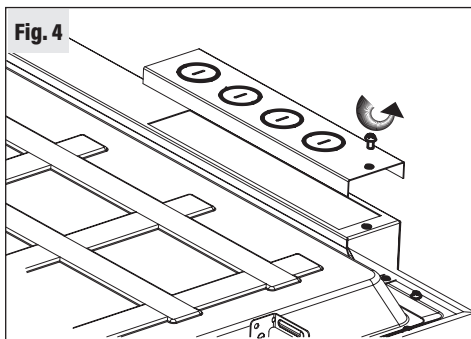

### SPEC-SELECT™ FIXTURES - FIELD ADJUSTABLE WATTAGE & CCT

(If applicable)

The end users may adjust the color temperature and lumen output, respectively, by the two slide switches integrated into the driver. Each switch has 3 options (left, middle and right), each position corresponds to 3 color temperatures (3500K, 4100K, and 5000K) and 3 wattages, which can be adjusted to the desired combination.

1. Switches are located on the driver. (Fig. 7)
2. Select a wattage and color temperature by sliding switch left or right respectively to the desired value.

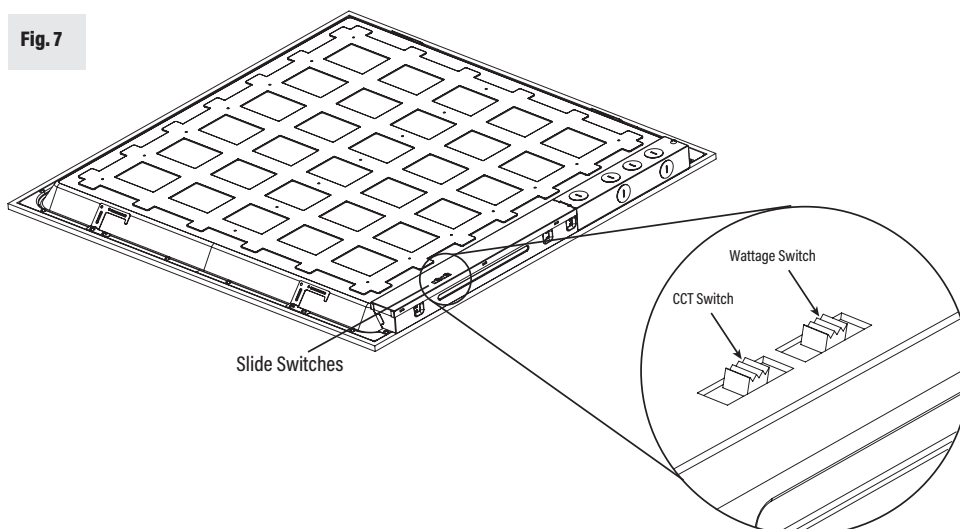

# LED BACK-LIT PANELS

## INSTALL INSTRUCTIONS



**WARNING** - TURN OFF POWER SUPPLY FROM MAIN CIRCUIT BREAKER BEFORE INSTALLING OR SERVICING.

### CABLE SUSPENDED MOUNTING *(Kit Sold Separately)*

1. Secure the round ceiling plate into the ceiling by using the expansion anchor and self-tapping screws. Confirm Cable A is fully pulled through and secure in the round ceiling plate. (Fig. 8)
2. Insert the end of Cable A into the cable gripper that is pre-attached on Cable B. Then adjust Cable A to the desired height and adjust Cable B to the desired angle. (Fig. 8)
3. Bend out earthquake brackets. Using the carabineers, connect Cable B to the large hole in the earthquake bracket and make final adjustments. (Fig. 9)
4. Connect LED driver to AC main power. (Fig. 6)

Fig. 8

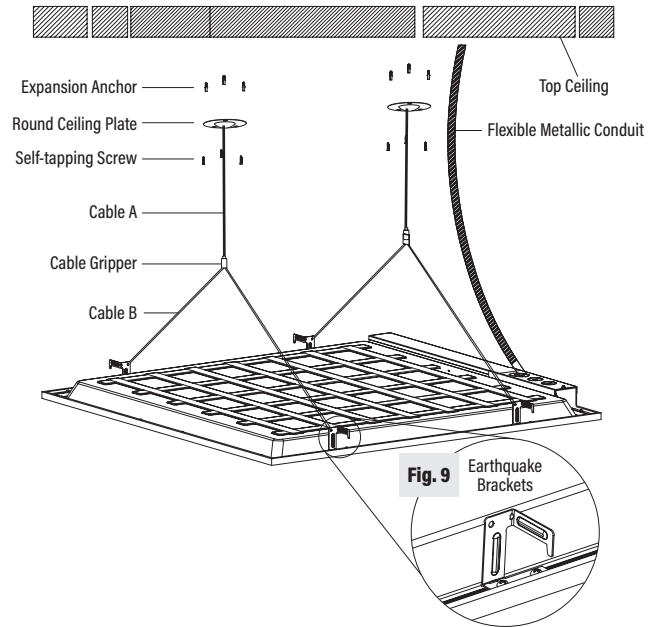

### SURFACE MOUNTING *(Kit Sold Separately)*

1. Assemble the mounting frame with the screws and the connection plate (Fig. 10).
2. Mount the frame on the ceiling with screws. Make sure that the wire is long enough for Step 4 below. (Fig. 11).
3. After mounting the frame on the ceiling, remove one side of the mounting frame (Fig. 12).
4. Connect the wires from the main to the LED driver, then slide the LED panel into the frame (Fig. 13).
5. Replace the side of the frame (Fig. 14).

