

LEDone®

LED LOC-GDHB High Bay Light HV Series



FEATURES

- IP65 rated
- Optional microwave sensor and emergency backup
- Easy installation and maintenance
- Corrosion and rust proof
- 50,000 hours lifetime

SUITABLE APPLICATIONS

- Warehouses
- Stadiums
- Factories
- Supermarkets
- Logistic Centers
- Exhibition Halls

CONSTRUCTION:

Unique design with built-in sensor. The lens has a spherical design and can emit light evenly. Each product is equipped with a shorting cap which is convenient for customers to replace the sensor.

OPTICAL SYSTEM:

Seoul SMD LED chips. 120° beam angle

WARRANTY

5-year limited warranty. Actual performance may differ as a result of end-user environment and application.

ELECTRICAL:

Available as 120-347V or 277-480V input. 8FT cord comes standard on 120-347V. 5FT cord comes standard on 277-480V. -40°F to 122°F

INSTALLATION & MOUNTING:

Hanging hook or U-Bracket.

CONTROLS & DIMMING:

0-10V dimming comes standard. Suitable for use with LED dimmers. Motion sensor and remote-control options available.



277-480V Models – 5FT cord comes standard

MODEL NUMBER – 5,000K	WATTAGE	LUMENS	EFFICACY	CRI	POWER FACTOR	THD	REPLACES
LOC-GDHB-150W-50KD-HV	150W	22,110LM	146lm/W	70	0.9	10.2%	400W – 600W HID
LOC-GDHB-200W-50KD-HV	200W	29,537LM	146lm/W	70	0.9	10.6%	600W – 750W HID
LOC-GDHB-250W-50KD-HV	250W	36,855LM	146lm/W	70	0.9	9.2%	750W – 1,000W HID

MEASUREMENTS (277-480V)

200W – 250W w/ Hook

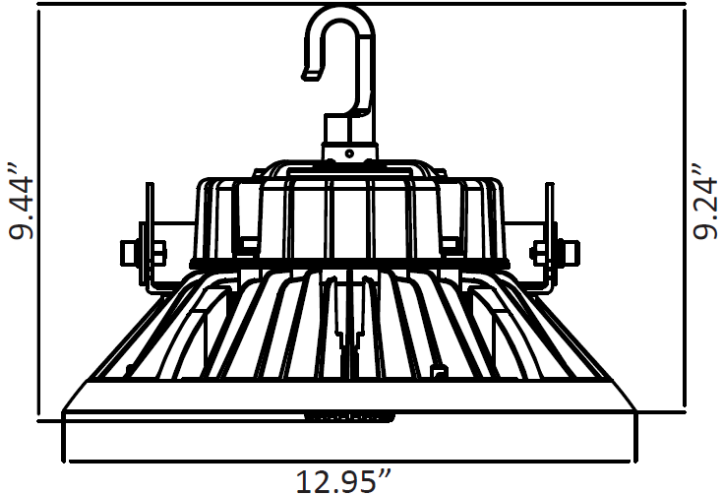

200W – 250W w/ U-Bracket

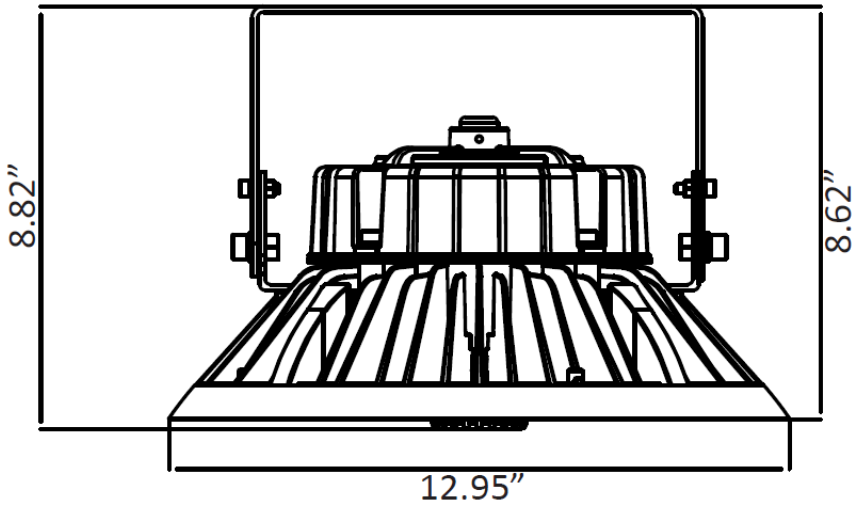

200W

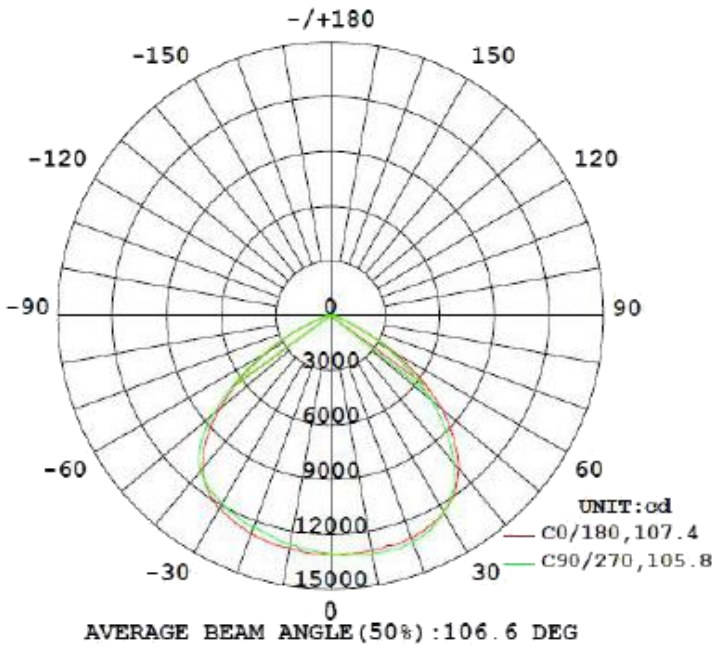

AAI Figure

Test: U:120.17V I:1.6828A P:201.76W PF:0.9977 Freq:60.01Hz Lamp Flux:30893.8x1 lm		
NAME: LED Fixed Luminaire	TYPE: LED	WEIGHT: N/A
SPEC: N/A	DIM: .	SERIAL No.: N/A
MFR.: LED One Corporation	SUR: .	Shielding Angle: N/A

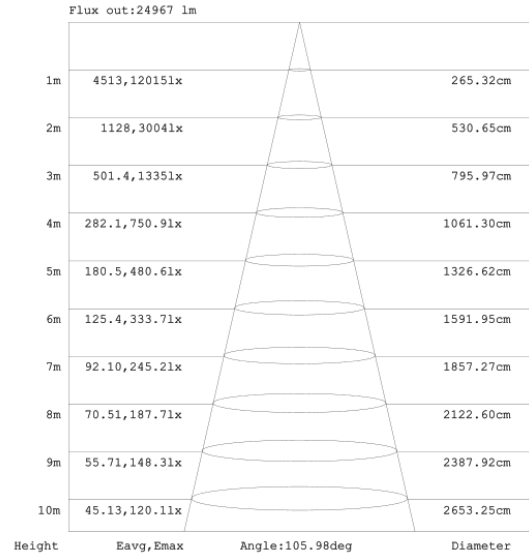

Note: The Curves indicate the illuminated area and the average illumination when the luminaire is at different distance.

250W

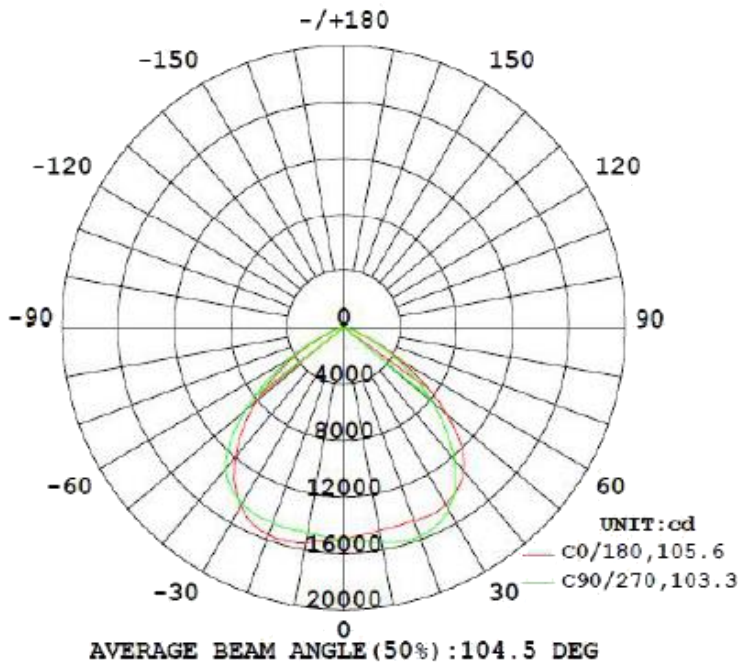

AAI Figure

Test: U:120.08V I:2.1233A P:254.36W PF:0.9977 Freq:60.01Hz Lamp Flux:38835.4x1 lm		
NAME: LED Fixed Luminaire	TYPE: LED	WEIGHT: N/A
SPEC: N/A	DIM: .	SERIAL No.: N/A
MFR.: LED One Corporation	SUR: .	Shielding Angle: N/A

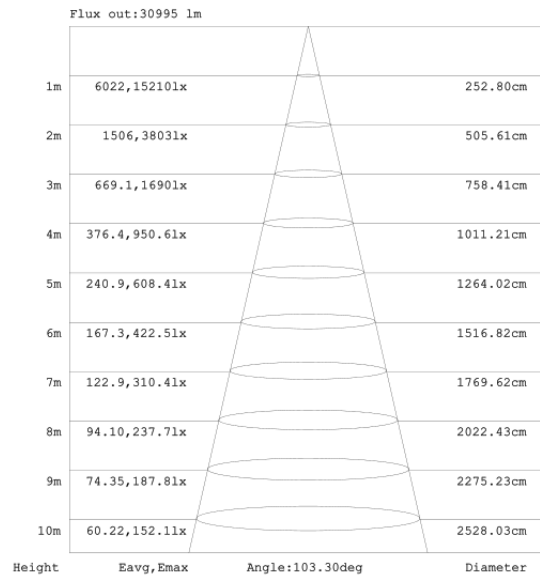

Note: The Curves indicate the illuminated area and the average illumination when the luminaire is at different distance.

MOUNTING OPTIONS



U-Bracket (optional) or Hook

OPTIONAL ACCESSORIES



Emergency Driver
LO-LOC-HBEMDR-25WHV