

LEDone®

LED LOC-ELHB High Bay Light Family Series

FEATURES

- **Multi Watt Models Only:**
 - Default Wattage is the highest wattage
 - 250W
 - Default CCT: 5,000K
- IP66 rated
- SPD 6KV
- Corrosion resistant
- Easy installation and maintenance
- 50,000 hours lifetime



180W / 200W / 250W

CONSTRUCTION:

Corrosive resistant polyester powder coat finish. PC3000U lens. Aluminum Alloy.

OPTICAL SYSTEM:

Philips Lumiled 3030 LED chips. 120° beam angle standard.

WARRANTY:

5-year limited warranty. Actual performance may differ as a result of end-user environment and application.

ELECTRICAL:

Available as 277-480V input.

Operating Temperature: -22°F to 122°F

SUITABLE APPLICATIONS

- Warehouse
- Manufacturing facilities
- Convention centers
- Sporting Arenas
- Big-box retail stores
- Cold storage facilities
- Gymnasiums

INSTALLATION & MOUNTING:

Hook mount.

DIMMING:

0-10V dimming



U-Bracket
(For multi watt models)



LED LOC-ELHB High Bay Light Family Series

LOC-ELHB-MW(180/200/250)MCCT(30/40/50)-HV

WATTAGE SELECTABLE	CCT SELECTABLE	LUMENS	EFFICACY	VOLTAGE	CRI	POWER FACTOR	THD	REPLACES
180W	3000K / 4000K / 5000K	24,300LM	135lm/W	277-480V	70	0.9	15%	600W – 1,000W HID
200W	3000K / 4000K / 5000K	27,000LM	135lm/W	277-480V	70	0.95	15%	600W – 1,000W HID
250W	3000K / 4000K / 5000K	33,750LM	135lm/W	277-480V	70	0.95	15%	600W – 1,000W HID

MEASUREMENTS

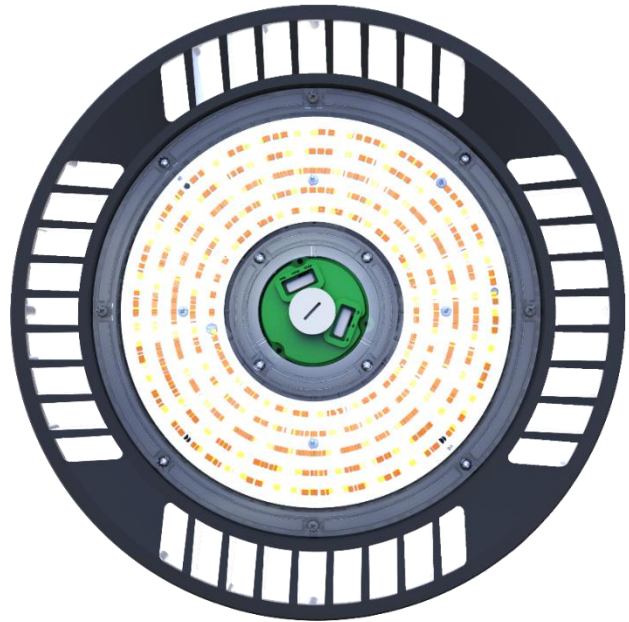
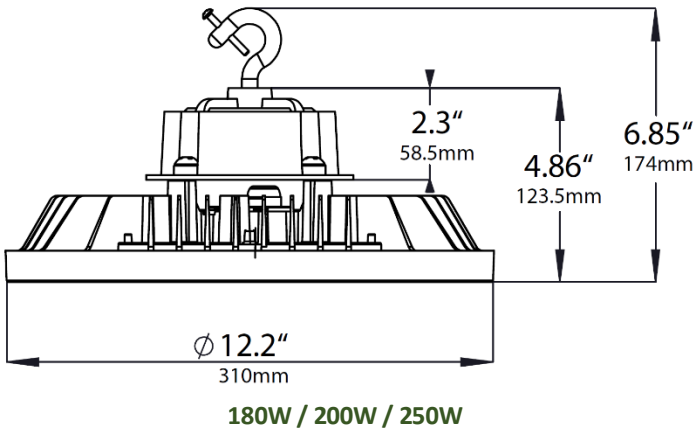

Multi Wattage Multi CCT Model

MOUNTING GUIDE

180W / 200W / 250W

RECOMMEND INSTALLATION HEIGHT 12-25FT

LOC-ELHB-MW(180/200/250)-50KD-LV 120°

The recommended installation distance is 1- 2H installation height.



Power	Equivalent	Height of Installation(FT)	Coverage(FT)	Center E(FC)
180W	400/600W HID	12-22	Dia36-66	20-70
200W	400/600W HID	12-23	Dia36-69	20-70
250W	600/1000W HID	14-25	Dia42-75	20-70

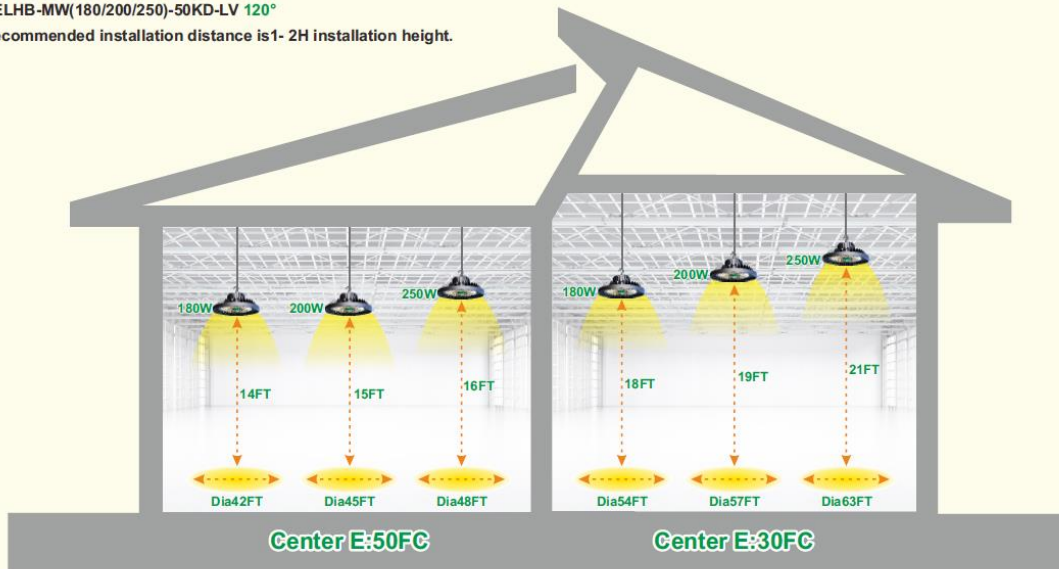

Roll over image to zoom in