

# 200W SHOEBOX PARKING LOT LED LIGHT

This wet-rated LED area light includes a Dusk to Dawn photocell sensor and 1-10V dimming. It features a durable, aluminum alloy housing and is easily installed in parking lots, campuses, parks, stadiums, or as a replacement for streetlights.

## MODELS

SB\_D2D-200W-5K-#PK

## LIGHT DISTRIBUTION ANGLE

LUMINOUS INTENSITY  
DISTRIBUTION DIAGRAM

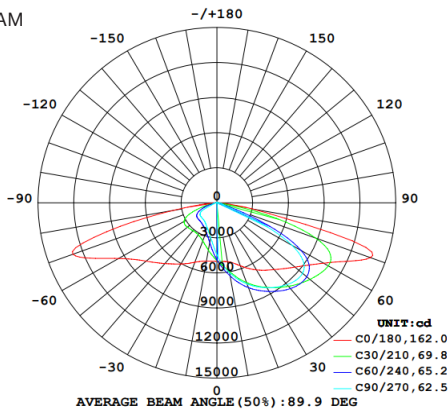

SPECTRUM  
TEST REPORT

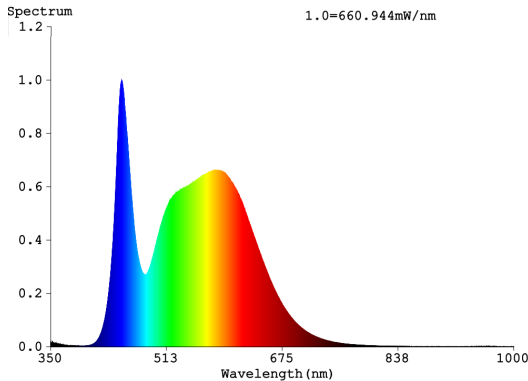

## CERTIFICATIONS

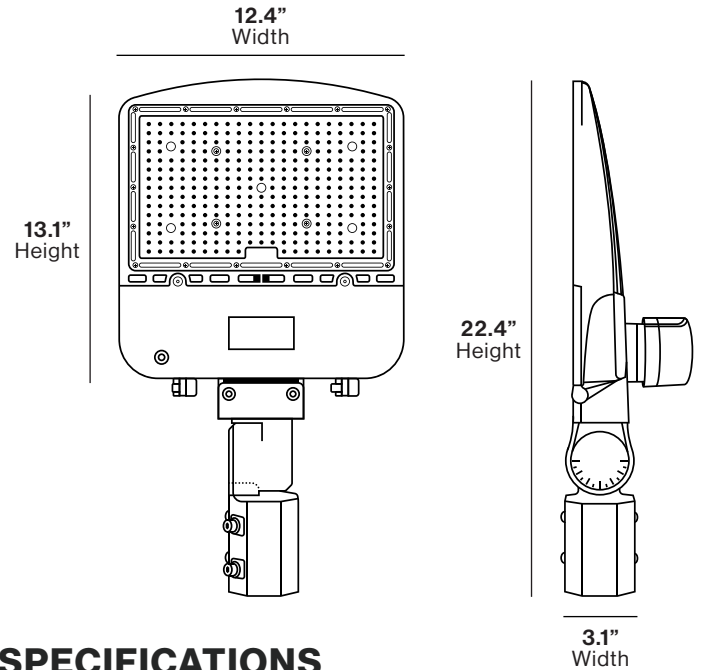

## SPECIFICATIONS

Voltage	100V-277V
Wattage	200
Current	1.85A
Power Factor	>0.9

## LIGHTING PERFORMANCE

Lumens	26,000
Equivalency	600W
Color Temperature	5000K
Color Rendering Index (CRI)	80
Beam Angle	155°/70°
Dimmable	Yes
Efficacy (lm/w)	130
Frequency	50/60 Hz

## ENVIRONMENT

Operating Temperature	-40°F to 113°F
Moisture Rating	Wet

## CONSTRUCTION

Housing Material	Aluminium
Weight	10 lbs

## LIFETIME

Average Lifetime	50,000+ hr
Switching Time	50,000
Warranty	7 Years