

150W SHOEBOX PARKING LOT LED LIGHT

This wet-rated LED light includes a Dusk to Dawn photocell sensor and 1-10V dimming. It features a durable, aluminum alloy housing and is easily installed in parking lots, campuses, stadiums, or as a replacement for streetlights.

MODELS

SB_D2D-150W-5K-#PK

LIGHT DISTRIBUTION ANGLE

LUMINOUS INTENSITY
DISTRIBUTION DIAGRAM

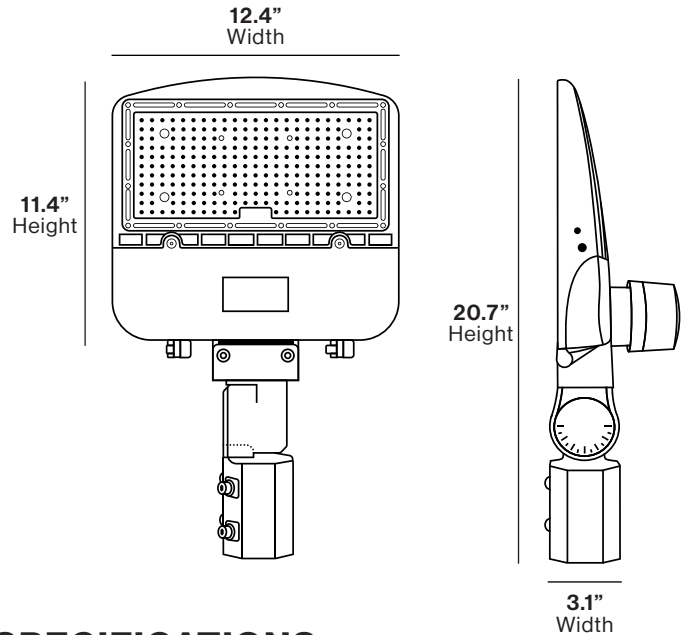
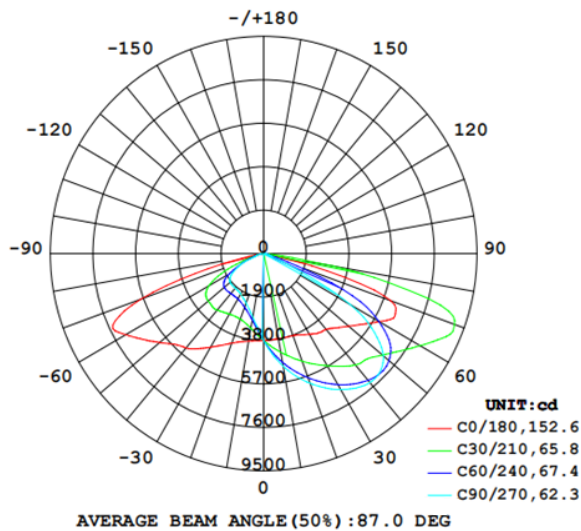

SPECIFICATIONS

Voltage	120-277
Wattage	150
Current	1.4A
Power Factor	>0.9

LIGHTING PERFORMANCE

Lumens	19,500
Equivalency	450W
Color Temperature	5000K
Color Rendering Index (CRI)	80
Beam Angle	155°/70°
Dimmable	Yes
Efficacy (lm/w)	130
Frequency	50/60 Hz

ENVIRONMENT

Operating Temperature	-40°F to 113°F
Moisture Rating	Wet

CONSTRUCTION

Housing Material	Aluminium
Weight	10 lbs

LIFETIME

Average Lifetime	50,000+ hrs
Switching Time	50,000
Warranty	7 Years

CERTIFICATIONS

