



Item#: **96655**

## LED 2X2 BACK-LIT PANEL

2X2 LUMINARIES FOR AMBIENT LIGHTING OF INTERIOR COMMERCIAL SPACES

### FEATURES

- High Efficiency, Energy Saving
- Up to 36% Savings vs. T8 Fluorescent
- Low glare, bright consistent lighting
- For covered ceilings only
- Earthquake proof hooks included

### APPLICATION

Ideal for offices, conference rooms, hospitals, lobbies, hotels, classrooms, workshops, cafeterias and other common areas.

### ELECTRICAL

Wattage	28W
Voltage	120-277V
Current	0.23-0.1A
Power Factor	0.9
Total Harmonic Distortion (THD)	11.1

### LIGHTING PERFORMANCE

Lumens	3584
Lumens Per Watt (LPW)	128
Color Temperature (CCT)	3500K
Color Rendering (CRI)	84
R9 (Red Value)	44
R13 (Skin Tones)	--
Beam Angle	120°
Light Distribution	Type VS
BUG Rating (Backlight, Uplight, and Glare)	--
Dimmable Lighting Control	<i>Dimmable</i> 0-10V, Range 10% - 100%

### ENVIRONMENT

Operating Temperature	-4° ~ 113°F
Suitable Location	<b>DAMP</b>
Ingress Protection Rating	IP40

### LIFESPAN

Average Life (Hours)	50,000
Warranty (Years)	<b>5</b>

### COMPONENTS

LED Light Source	--
Driver	--

### CONSTRUCTION

Housing	Aluminum
Lens	Frosted
Base / Power Supply	Hard Wired
Finish	White

### QUALIFICATIONS



Visit [www.designlights.org/search](http://www.designlights.org/search) to confirm qualification. • Published lumens on LED products are approximate and may vary slightly. • Specifications are subject to change without notice.

Item#: **96655**  
**LED 2X2 BACK-LIT PANEL**

**DIMENSIONS** (Inches)

Length	23.7"
Width	23.7"
Height	1.6"
Weight (Lbs)	--

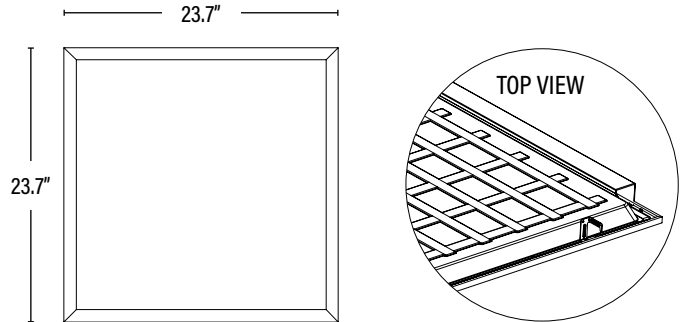

**SUPPORTING DOCUMENTS** (Grey = not available at this time.)

Product Sheet	VIEW
Install Instructions	VIEW
IES Download from Web Item	VIEW
LM79	VIEW
LM80	VIEW

PACKAGING		UPC	DIMENSIONS (LxWxH)	GROSS WEIGHT (Lbs)
Master Carton	2	10811768027591	--	--
Individual Box	1	811768027594	N/A	--
Country of Origin	China			
HS Tariff	9405.10.6020			

**ORDERING**

ITEM#	DESCRIPTION	CASE
96655	LED 2X2 PANEL/BLP/28W/35K/DIMM/120-277V - DLC®	2

**ACCESSORIES**

82155	2X2 FLANGE KIT FOR PANEL & TROFFER/WHT	1
13555	2X2 SURFACE MOUNTED KIT FOR LED BACK-LIT PANEL/WHT	1
54455	SUSPENDED CABLE MOUNTING KIT FOR LED PANEL	100
49355	EMERGENCY PACK FOR LED PANEL 8W/90 MIN	10
39355	MOUNTING BRACKET AND WIRE BOXES FOR 55394 EMERGENCY PACK FOR LED 2X2 OR 2X4 PANEL	20

**ADDITIONAL INFORMATION:**

Family Item(s): 07655/4000K