



Item#: **69845**
OCCUPANCY SENSOR
 FIXTURE ACCESSORY

FEATURES

- Includes two lenses
- 30' range sensitivity detector
- Pre-stripped color coded wire leads
- Uses infrared energy as its control signal source
- Smart timing detection logic

APPLICATION

Designed for use with indoor fixtures in warehouses, work stations, hallways and offices.

360° TOP AND SIDE VIEW

LOW BAY

HIGH BAY

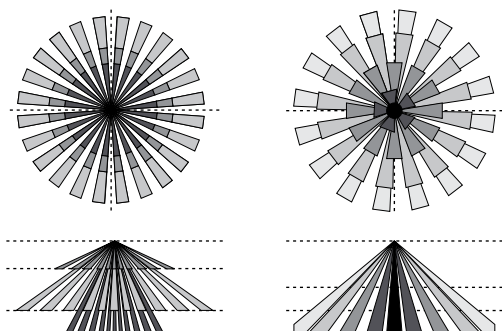

ELECTRICAL

Voltage	120V-277V • 50/60 Hz	
Load Requirements	Incandescent / Halogen	800W/1200W @ 120/277V
	Fluorescent Ballast	800W/1200W @ 120/277V
	Electronic Ballast (LED)	800W/1200W @ 120/277V

PERFORMANCE

Field of View	360°
Coverage Area	30'
Coverage Area for PIR Lens 1	25' Height
Coverage Area for PIR Lens 2	40' Height
Adjustable Time Delay	10 Sec. - 30 Min.
Adjustable Light Control	10 - 300 Lux

ENVIRONMENT

Operating Temperature	-40° ~ 167°F
Suitable Location	Indoor Only
Humidity	Max. 95% RH

LIFESPAN

Warranty (Years)	2
------------------	----------

CONSTRUCTION

Housing	PC
Mounting	½" Knockout / Hard Wired
Finish	White

QUALIFICATIONS



Specifications are subject to change without notice.

Item#: **69845**
OCCUPANCY SENSOR

ITEM INFORMATION

DIMENSIONS (Inches)

Length	4"
Width	3.2"
Height	1.7"
Net Weight (Lbs)	--

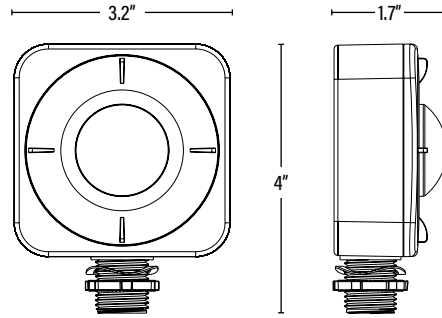

SUPPORTING DOCUMENTS (Grey = not available at this time.)

Product Sheet	VIEW
Install Instructions	VIEW

PACKAGING

		UPC	DIMENSIONS (LxWxH)	GROSS WEIGHT (Lbs)
Master Carton	50	10811768021698	19.5" x 13" x 10.8"	24.5
Individual Box	1	811768021691	3.7" x 1.9" x 4.9"	0.5
Country of Origin	China			
HS Tariff	8536.50.9065			

ORDERING

ITEM#	DESCRIPTION	CASE
69845	LOW/HIGH BAY FIXTURE OCCUPANCY PIR SENSOR 30FT DIA, 8-40FT HEIGHT 800W/1200W • 120/277V	50

ACCESSORIES

49845	EXTENDER MOUNT FOR SENSOR 69845/79845/89845	100
-------	---	-----

ADDITIONAL INFORMATION:

Included lenses:



L1
Low Bay

L2
High Bay

View of settings switch (beneath lens):

