



Item#: **49845**
EXTENDER MOUNT FOR SENSOR
ACCESSORY

APPLICATION

For use with occupancy sensors to extend the connection to the fixture.

DIMENSIONS (Inches)

Length	6.4"
Width	1.6"
Height	2"
Net Weight (Lbs)	--

SUPPORTING DOCUMENTS (Grey = not available at this time.)

Product Sheet	VIEW
---------------	------

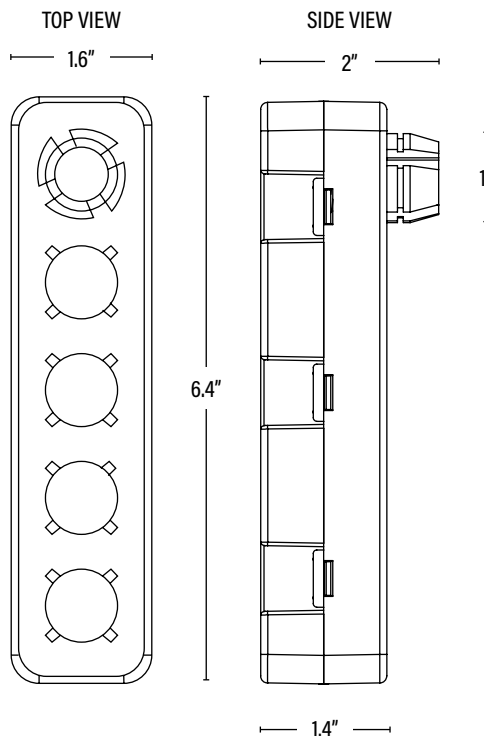

PACKAGING		UPC	DIMENSIONS (LxWxH)	GROSS WEIGHT (Lbs)
Master Carton	100	10811768025757	--	--
Individual Item	1	811768025750	--	--
Country of Origin	China			
HS Tariff	8536.50.9065			

ORDERING

ITEM#	DESCRIPTION	CASE
49845	EXTENDER MOUNT FOR SENSOR 69845/79845/89845	100