



Item#: **07555**

LED 2X2 SPEC-SELECT™ BACK-LIT PANEL

2X2 LUMINAIRES FOR AMBIENT LIGHTING OF
INTERIOR COMMERCIAL SPACES

FEATURES

Spec-Select™ Panels feature adjustable wattage and color temperature for the perfect balance of light in any application.

- Energy efficient
- No flickering

APPLICATION

Ideal for retrofitting inefficient fixtures in malls, hospitals, airports, offices, lobbies and other residential and commercial applications.

ELECTRICAL

Wattage	20W / 25W / 30W
Voltage	120-277V
Current	0.25-0.10A
Power Factor	0.9
Total Harmonic Distortion (THD)	10

LIGHTING PERFORMANCE

Lumens	2520 / 3150 / 3780
Lumens Per Watt (LPW)	126
Color Temperature (CCT)	3500K / 4100K / 5000K
Color Rendering (CRI)	82
R9 (Red Value)	12
R13 (Skin Tones)	84
Beam Angle	120°
Light Distribution	Type VS
BUG Rating (Backlight, Uplight, and Glare)	B2 - U1 - G1
Dimmable Lighting Control	<i>Dimmable</i> 0-10V, Range 10% - 100%

ENVIRONMENT

Operating Temperature	-4° ~ 122°F
Suitable Location	DAMP
Ingress Protection Rating	IP40

LIFESPAN

Average Life (Hours)	50,000
Warranty (Years)	5

COMPONENTS

LED Light Source	Runlite 2835
Driver	SIF30-I0800

CONSTRUCTION

Housing	Aluminum
Lens	Frosted
Base / Power Supply	Hard Wired
Finish	White

QUALIFICATIONS



Visit www.designlights.org/search to confirm qualification. • Published lumens on LED products are approximate and may vary slightly. • Specifications are subject to change without notice.

Item#: **07555**
LED 2X2 SPEC-SELECT™ BACK-LIT PANEL

ITEM INFORMATION

DIMENSIONS (Inches)

Length	23.7"
Width	23.7"
Height	1.5"
Weight (Lbs)	5.8

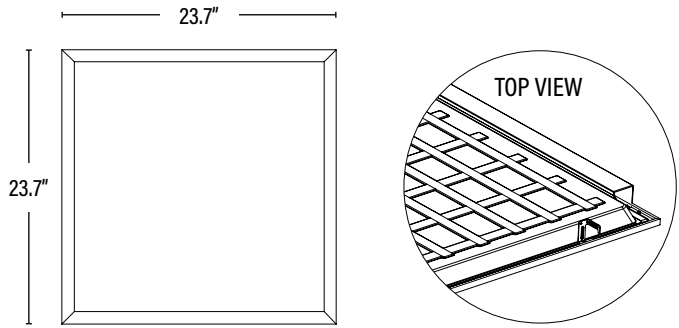

SUPPORTING DOCUMENTS (Grey = not available at this time.)

Product Sheet	VIEW
Install Instructions	VIEW
IES Download from Web Item	VIEW
LM79	VIEW
LM80	VIEW

PACKAGING

		UPC	DIMENSIONS (LxWxH)	GROSS WEIGHT (Lbs)
Master Carton	2	10811768021155	--	--
Individual Item	1	811768021158	N/A	--
Country of Origin	China			
HS Tariff	9405.10.6020			

ORDERING

ITEM#	DESCRIPTION	CASE
07555	LED 2X2 SPEC-SELECT™ PANEL/BLP/20-25-30W/35-50K/DIMM/120-277V - DLC®	2

ACCESSORIES

82155	2X2 FLANGE KIT FOR PANEL & TROFFER/WHT	1
13555	2X2 SURFACE MOUNTED KIT FOR LED BACK-LIT PANEL/WHT	1
54455	SUSPENDED CABLE MOUNTING KIT FOR LED PANEL	100
49355	EMERGENCY PACK FOR LED PANEL 8W/90 MIN	10
39355	MOUNTING BRACKET AND WIRE BOXES FOR 55394 EMERGENCY PACK FOR LED 2X2 OR 2X4 PANEL	20

ADDITIONAL INFORMATION:

- Default settings; 30W, 5000K.
- The color temperature and wattage may be adjusted by two slide switches integrated into the driver, selection should be made prior to installation.

