

# Sunco

Lighting made better.

User Manual

## 1x2 LED Selectable Ceiling Panel

SKU: PN12\_DU-WH-3550K

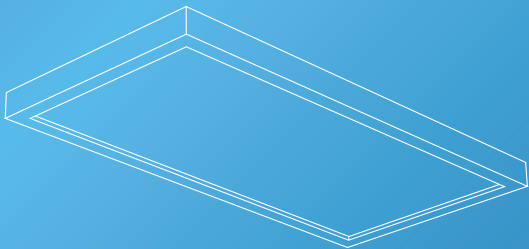

support@sunco.com  
(844) 334-9938



AMERICAN  
COMPANY

# Whats in the Box?

## Ceiling Panel

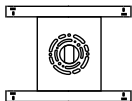
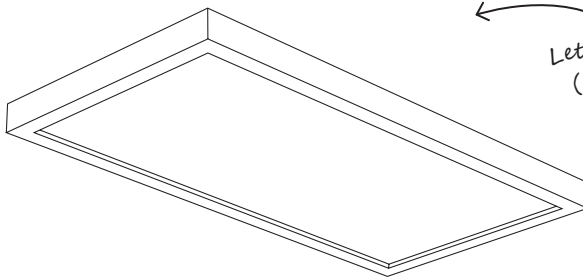

**x1**

Mounting Bracket



**x4**

Safety Cable



**x3**

Wire Nuts

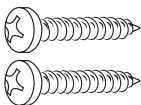

**x4**

Screws

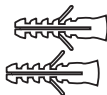

**x4**

Plastic Anchors

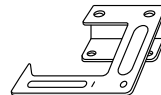

**x4**

Shockproof Hook

# Before You Start

## Safety Information

To reduce the risk of fire, electric shock, or physical injury:

- Turn off circuit breaker before installing this fixture.
- Suitable for use in Damp environments at temperatures ranging from -4°F to 113°F.
- Not for use where directly exposed to water.
- Not intended for use with emergency fixtures.
- Not compatible with photo controls.
- Not compatible with occupancy sensors.
- Not compatible with third party sensors.
- Not compatible with all dimmers. For more dimming information, please visit [www.sunco.com](http://www.sunco.com).
- Not compatible with timing devices.
- All electrical connections must be in accordance with local and National Electric Code (N.E.C.) standards.
- Please review installation manual carefully before proceeding. Consult a qualified electrician if you are unfamiliar with proper electrical wiring connections.

**⚠ WARNING:**  
Cancer & Reproductive Harm - [www.P65Warnings.ca.gov](http://www.P65Warnings.ca.gov)

This device complies with Part 15 of the FCC rules. Operation is subject to the following two conditions:  
1.) This device may not cause harmful interference.

2.) This device must accept any interference that may cause undesired operation. Please review all instructions carefully prior to installation.

## Dimensions

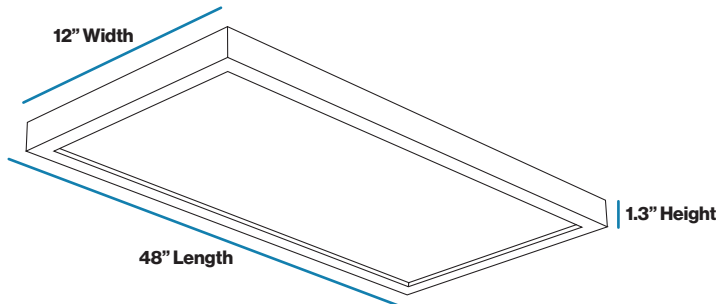

# Installation Guide

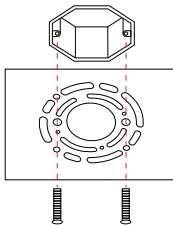

## STEP 1

- a. Turn off circuit breaker before installation.
- b. Use screws to attach mounting bracket to existing junction box  
Use with 2.1", 2.75", or 3.5" junction box.

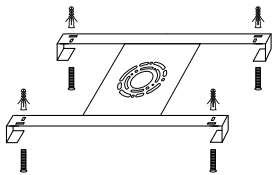

## STEP 2

- a. If no junction box is present, attach mounting bracket to ceiling using (4) plastic anchors and screws.

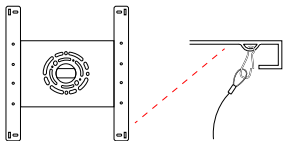

## STEP 3

- a. Clip safety cable from light to mounting bracket for added security.

# Installation Guide (Cont.)

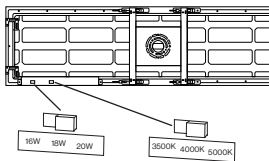

## STEP 4

a. Use switches to choose CCT and brightness settings:

Brightness	CCT
-16W : 1600LM	-3500K
-18W : 1800LM	-4000K
-20W : 2000LM	-5000K

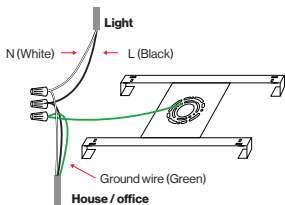

## STEP 5

a. Connect supply wires to fixture wires.

b. Black to Black (Live); White to White (Neutral); Green to Green (Ground)

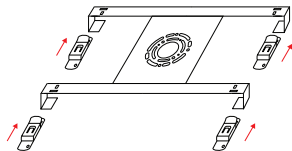

## STEP 6

a. Hold panel flush against ceiling, then slide and lock into place.

b. Turn on circuit breaker and test light.

# Product Details

## Recommended Dimmers

Brand	Model
EATON	AAL06-C1
LEVITON	R50-IPL06-10M
LEVITON	R62-06674-POW
LUTRON	CTCL-153PDH-WH
LUTRON	DVCL-153PR-WH
LUTRON	MACL-153MH-WH
LUTRON	P-PKG1W-WH-R
LUTRON	TGCL-153PH-WH

*Scan for the full compatible dimmer list!*



## Specifications

<b>Voltage</b>	120V	<b>Average Lifetime</b>	50,000 hrs
<b>Wattage</b>	16W/18W/20W	<b>Lumens</b>	1600/1800/2000lm
<b>Power Factor</b>	0.9	<b>Temperature</b>	-4°F to 113°F
<b>Beam Angle</b>	120°	<b>Frequency</b>	60HZ
<b>CCT</b>	3500K/4000K/5000K	<b>Efficacy</b>	100lm/w
<b>CRI</b>	80/90	<b>Moisture Rating</b>	Damp
<b>Dimmable</b>	0-10V	<b>Warranty</b>	7 Years

# Common Troubleshooting

Feeling in the dark about an issue with your product? No worries! Our troubleshooting section is here to shed some light and provide you with easy-to-follow solutions for any problem.

If you still need some assistance, please feel free to contact us with any questions. Our team of lighting experts are happy to help brighten your day.

## Installation

Light isn't turning on.

Double check if fixture is properly connected and circuit breaker hasn't been tripped.

Light unexpectedly fails.

For further assistance, reach out to customer support.

## Dimming

Light not dimming to lowest setting.

Ensure minimum dimmer load requirement is met.

Light not dimming smoothly.

Verify dimmer compatibility with fixture.

Light not compatible with dimmer switch.

Check light-dimmer compatibility. Consider purchasing compatible switch if necessary.

## Flickering

Light is flickering when turning on.

Check that fixture wiring connections are secure.

Light flickering with other lights on the same circuit.

Check that the lights on the same circuit are not overloading the circuit.

Light flickering when turned on.

Verify fixture compatibility and that it is grounded.

Light flickering when dimmed.

Verify dimmer switch compatibility.

## Buzzing

Fixture buzzing with power outages.

Verify light is connected to surge protector securely.

Fixture buzzing with appliances or electronic devices.

Look for nearby interferences that can cause buzzing. Such as televisions, radios, computers, etc.

Fixture buzzing when dimmed.

Verify dimmer switch compatibility.

# Light Distribution Angle

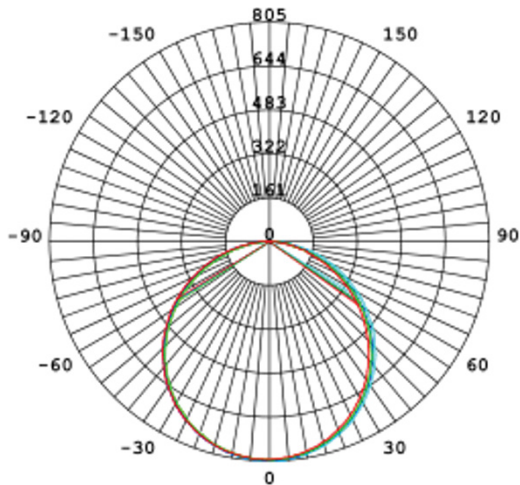

←  
*Not a lighting nerd?  
No worries, you can skip this page*

AVERAGE BEAM ANGLE (50%): 113.7 DEG

<span style="color: cyan;">—</span>	C0/180	115.6°
<span style="color: blue;">—</span>	C30/210	113.5°
<span style="color: green;">—</span>	C60/240	112.9°
<span style="color: red;">—</span>	C90/270	112.7°

UNIT:cd Luminous Intensity Distribution 1

Lighting distribution angle refers to the spread of light emitted from a light source. It is an important factor to consider when selecting a fixture or bulb, as it affects the way it will illuminate an area. There are two main types of lighting distribution angles:

A symmetric lighting distribution emits light evenly in all directions, creating a cone-shaped pattern that provides a pool of light. This type of lighting is ideal for general lighting and illuminating large areas. Common applications for symmetric lighting include general area illumination, security lighting, and perimeter lighting. Symmetric lighting is also used to a certain degree in up-lighting.

An asymmetric lighting distribution angle, also known as beam angle, creates a pattern that focuses light in a specific direction. This type of lighting is ideal for task lighting as it reduces glare and light spill in other areas. Common applications include task lighting in spaces such as landscape settings, retail stores, museums, and much more.

It is important to note that the lighting distribution angle can also be affected by other factors such as the reflector design of the light source, the type of lens used, and the distance between the light source and the surface being illuminated.



## Warranty Policy

This product is covered by our industry leading 7 year warranty.

It gets even better - scan the QR code for 2 extra years of protection!



*Scan me for two extra years!*

## 30 Day Return Policy

At Sunco, we value our customers and stand by the quality and performance of our products.

If you are not completely satisfied with your purchase, we accept returns within 30 days of your purchase date.

## Customer Service

Our Los Angeles team of lighting experts is here to assist you with all your needs! Contact us at:

Email: [support@sunco.com](mailto:support@sunco.com)

Call or Text: (844) 334-9938

# Sunco

Lighting made better.

[support@sunco.com](mailto:support@sunco.com)  
(844) 334-9938

REV1.0



AMERICAN  
COMPANY