

LED TROFFER RETROFIT FIXTURES

INSTALL INSTRUCTIONS

PLEASE FIND A QUALIFIED ELECTRICIAN FOR INSTALLATION. Please read the instructions before you install and use the luminaire.

Before installing, servicing, or performing routine maintenance upon this equipment, follow these general precautions:

- **WARNING** - Risk of Fire or Electric Shock. The electrical rating of these products are 120-277V, the installer must determine whether they have 120-277V at the luminaire before installation.
- **WARNING** - Risk of Fire or Electric Shock. LED Retrofit Kit installation requires knowledge of luminaires electrical systems. If not qualified, do not attempt installation. Contact a qualified electrician.
- **WARNING** - Risk of Fire or Electric Shock. Install this kit only in luminaires that have the construction features and dimensions shown in the photographs and/or drawings; and where the input rating of the retrofit kit does not exceed the input rating of the luminaire.
- **WARNING** - To prevent wiring damage or abrasion, do not expose wiring to edges of sheet metal or other sharp objects.
- **WARNING** - Risk of Fire or Electric Shock. Luminaire wiring and electrical parts may be damaged when drilling for installation of LED Retrofit Kit. Check for enclosed wiring and components.
- Do not make or alter any open holes in an enclosure of wiring or electrical components during kit installation.
- Turn off electrical power at fuse or circuit breaker box before wiring fixture to the power supply.
- Turn off the power when you perform any maintenance.
- All wiring connections should be capped with UL approved wire connectors.
- To reduce the risk of death, personal injury or property damage from fire, electric shock, falling parts, cuts/abrasions, and other hazards read all warnings and instructions included with and on the fixture box and all fixture labels.
- Commercial installation, service and maintenance of luminaires should be performed by a qualified licensed electrician.
- For the installation: If you are unsure about the installation or maintenance of the luminaires, consult a qualified licensed electrician and check your local electrical code.

CAUTION: RISK OF INJURY

- Avoid direct eye exposure to the un-louvered light source while it is on.
- Account for small parts and destroy packing material, as these may be hazardous to children.
- Risk of burn. Disconnect power and allow fixture to cool before changing bulb or handling fixture.
- Green ground screw provided in proper location. DO NOT RELOCATE.
- Minimum 90° supply connectors.
- Suitable for Dry or Damp location, Type IC

! WARNING - TURN OFF POWER SUPPLY FROM MAIN CIRCUIT BREAKER BEFORE INSTALLING OR SERVICING.

INSTALLATION

1. Prior to installation, disconnect all incoming power to fixture. Remove existing hardware (lens/lens frame, parabolic louver, reflectors/ballast covers, brackets, lamps/lamp holders). Leave supply and grounding leads. (Fig. 1)
- NOTE:** Follow all federal and local regulations when disposing of lamps and removed components.
2. Install LED panel end brackets to each end of the existing fixture by gently lifting it and placing LED panel end brackets between the fixture and T-grid. (Fig. 1)
 3. If there is a gap between the fixture and T-grid, LED panel side brackets can be installed between the fixture and T-grid. There are two tabs to allow for placing the side brackets into the slot of end brackets. (Fig. 2)
 4. Secure the LED panel brackets to the existing fixture using the provided #8 x 1/2" self-drilling screws. (Fig.3)
 5. Locate the LED Troffer Retrofit onto the keyholes of the end brackets, and then slide the LED Troffer Retrofit horizontally onto the end slots. (Fig. 4)

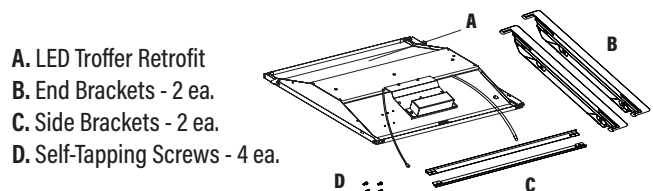

Fixture Size	Maximum Inner Dimensions
2' x 2'	24" x 23.9" x 3.1"
2' x 4'	48" x 23.9" x 3.1"

Fig. 1

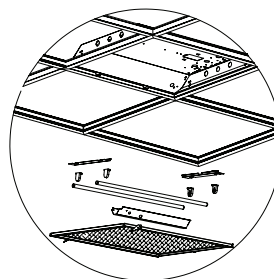
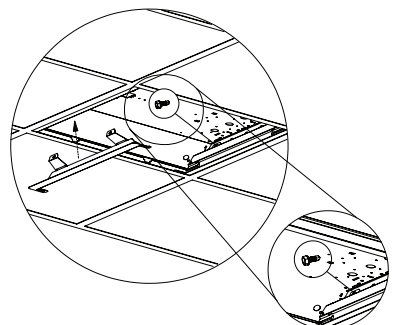

Fig. 2



LED TROFFER RETROFIT FIXTURES

INSTALL INSTRUCTIONS

WARNING - TURN OFF POWER SUPPLY FROM MAIN CIRCUIT BREAKER BEFORE INSTALLING OR SERVICING.

- Hook the safety cables into the holes positioned on the end brackets.
- Use the provided wire caps to connect the wire leads of the troffer kit to the main power leads. (Black-Live, White-Neutral and Green-Ground) (Fig. 5)
- Secure the LED Troffer Retrofit by locking the latches riveted on each end of the frame. (Fig.6)

Fig. 3

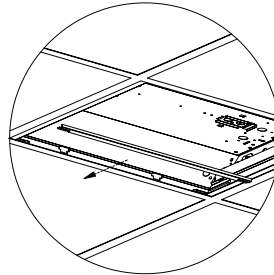

Fig. 4

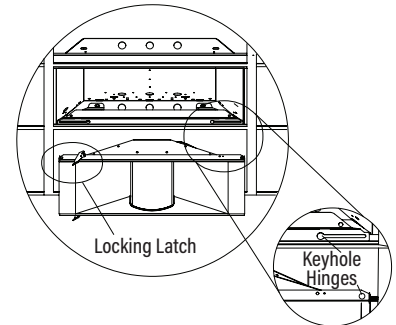

Fig. 5

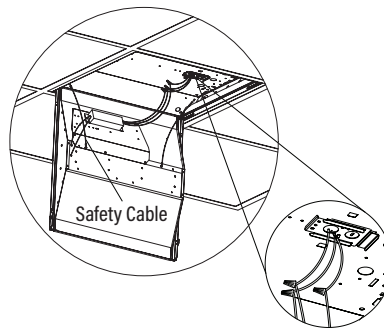
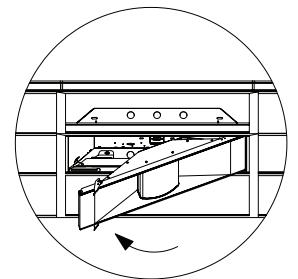
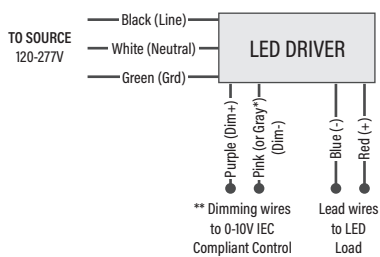

Fig. 6



GENERAL WIRING DIAGRAM



**Per NEMA rule-change, gray-color dimming control wires will be changing to pink as new productions come in.*

SPEC-SELECT™ FIXTURES - FIELD ADJUSTABLE WATTAGE & CCT (If applicable)

The end users may adjust the color temperature and lumen output, respectively, by the two slide switches integrated into the back of the fixture. Each switch has 3 options (left, middle and right), each position corresponds to 1 of 3 color temperatures (3500K, 4100K, and 5000K) and 1 of 3 wattages, which can be adjusted to the desired combination.

- Switches are located on the driver. (Fig. 7)
- Select a wattage and color temperature by sliding switch left or right respectively to the desired value. (Fig. 7)

Fig. 7

