

**HYPERLITE**

[www.hi-hyperlite.com](http://www.hi-hyperlite.com)

**HYPERLITE**

[www.hi-hyperlite.com](http://www.hi-hyperlite.com)

A good & brand new product. Congrats!  
Enjoy brighter life now.

Feel free to contact us  
Email: [service@hi-hyperlite.com](mailto:service@hi-hyperlite.com)  
Toll-free number: +1(855) 688 7879



LED String Work Light

RELIABLE SOLID BRIGHT

**FEATURES & SPECIFICATIONS**

Performance Data		HLWL-B-50L-5LED	HLWL-B-100L-10LED
General	Lumens	5000 LM	10000 LM
	Efficacy	100LM/W	
	CCT	5000K	
	CRI	≥80	
	Color finish	Yellow & White	
Electrical	Power	50W	100W
	Input voltage	AC 120V	
Physical & Listing	Length	50 ft	100 ft
	Listing	ETL	
	IP rating	IP 65	
	Warranty	3 Years	

**DIMENSION**

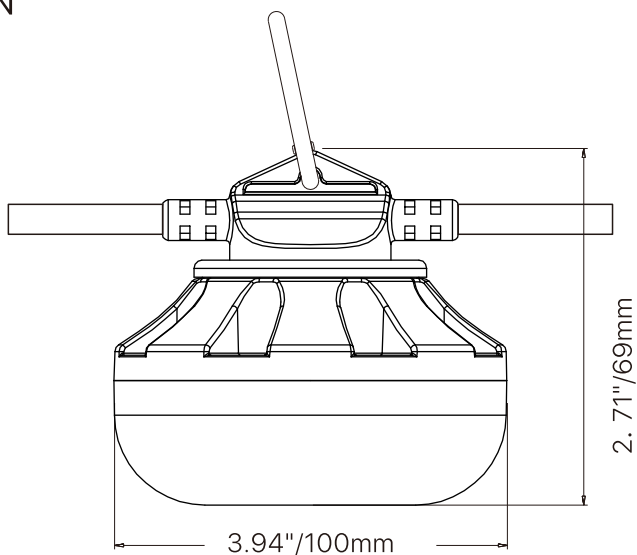

**ATTENTION**

**BEFORE YOU USE**  
Read these instructions completely and carefully.

**⚠ WARNING**

- Do not submerge the Work Light in water.
- Do not obstruct walkways or common areas with the cord.
- Do not modify this fixture. Any modifications may render the product unsafe and void warranty.

**Prepare Electrical Wiring**



**Electrical Requirements**  
The LED driver must be supplied with 120VAC, 60 Hz per product label and connected to an individual properly grounded branch circuit, protected by a 15 or 20 ampere circuit breaker.

**▲ NOTE!**

- This product is suitable for wet locations.
- Do not operate the Work Light in explosive atmospheres, such as in the presence of flammable liquids, gases or dust. The Work Light generates sparks which may ignite the dust or fumes.
- Do not leave the Work Light unattended when it is plugged into. Unplug it from its electrical outlet before leaving.

**CONNECTING STRING LIGHT**

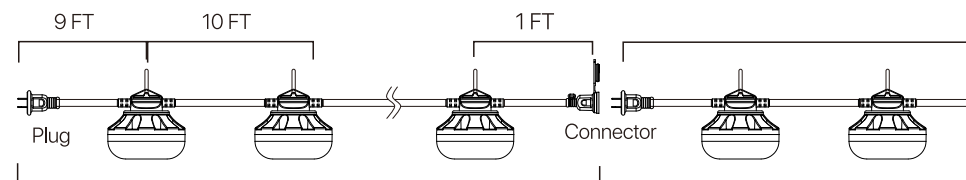

50 FT/5 lamps

Additional String Light up to 18 string lights maximum

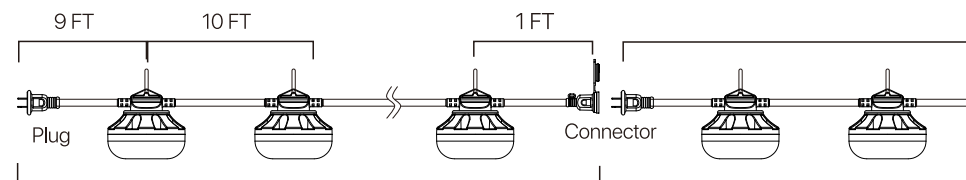

100 FT/10 lamps

Additional String Light up to 9 string lights maximum

Note: Total connection do not exceed 960 Watts.