

READ THOROUGHLY BEFORE INSTALLATION

▲ **WARNING!** FIXTURES MUST BE GROUNDED and installed in accordance with the National Electrical Code and all local codes. Failure to do so may increase the **RISK OF PERSONAL INJURY, PROPERTY DAMAGE, FIRE AND DEATH.**

▲ **WARNING!** Dangerous voltage exist within the unit and all precautions usually observed in handling high voltage equipment should be observed when replacing light engine or otherwise servicing luminaires. Disregarding this warning could result in electrical shock and possible injury to the individual installing or servicing this equipment. Installation, service and maintenance of luminaires should be done by a **qualified licensed electrician.**

▲ **CAUTION!** To reduce the risk of death, personal injury or property damage from fire, electric shock, falling parts, cuts/abrasions, and other hazards please read all warnings and instructions included with and on the fixture box and all fixture labels.

▲ NOTE!

- This equipment is only for professional installation. Non-professional personnel shall not remove or install the equipment.
- To avoid damage, falling, electric shock or fire, please do not modify the lamp or replace accessories without confirming with the supplier.
- Maintenance/installation and replacement the lamps , please confirm to cut off the power supply, and the lamps have set up a cooling. Please make sure the lamps properly installed before processing power.
- Ensure the accurate and reliable connection.
- Ensure that the product around the vent, the lamp cannot violate any fire prevention regulations when using.

Carefully read these instructions before installing product and keep it for future reference. If you do not understand these instructions, before starting any work, contact service@hi-hyperlite.com or (855) 688-7879.

HYPERLITE

www.hi-hyperlite.com

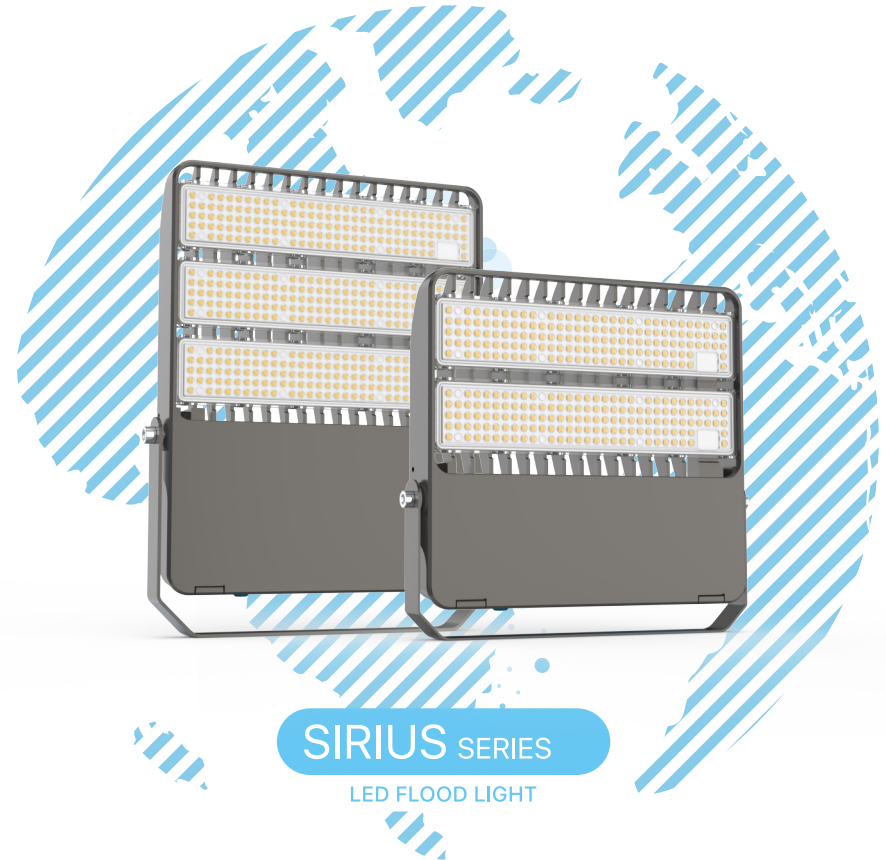

RELIABLE SOLID BRIGHT

Web: www.hi-hyperlite.com

Email: service@hi-hyperlite.com

Tel: +1(855) 688 7879

LED FLOOD LIGHT

SIRIUS Series

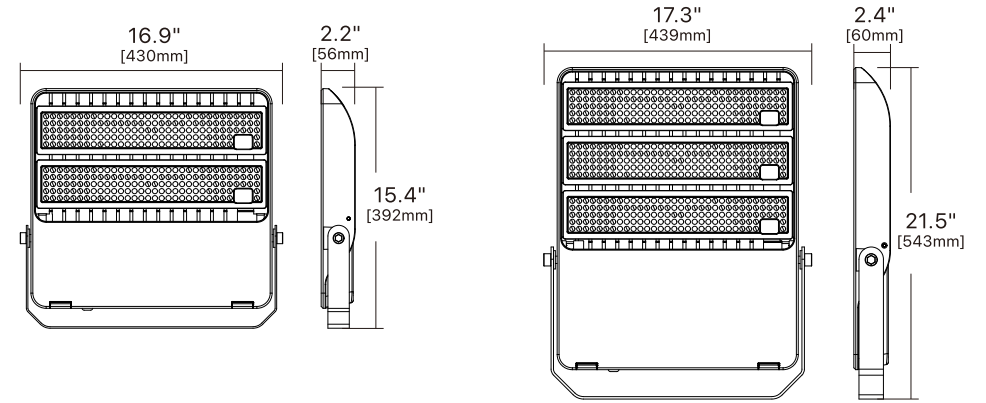

Model	Wattage	Qty/Ctn	Net Weight	Gross Weight	CTN Size
CES-LS-SI-200W	200W	1	11.5 ± 1 lbs	14.6 ± 1 lbs	19.9"*18.8"*5.3"
CES-LS-SI-300W	300W	1	16.3 ± 1 lbs	19.9 ± 1 lbs	24.7"*20.0"*5.5"

FEATURES & SPECIFICATIONS

Performance Data		CES-LS-SI-200W	CES-LS-SI-300W
General	Lumens	28000lm	42000lm
	Efficacy	140 lm/W	
	CCT	5000K	
	Beam angle	90°	
	CRI	>70	
	Life span	>50,000 hours	
	Color finish	Black	
Electrical	Power	200W	300W
	Input voltage	100 - 277V	
	Power factor	>0.9	
	Temperature	-22°F to 113°F (-30°C to 45°C)	
Physical & Listing	Wire Length	1.5 M	
	Mounting	U-bracket Mount	
	IP rating	IP 65	
	Warranty	5 Years	

INSTALLATION INSTRUCTIONS

U-bracket Trunnion Mount

1. Loosen light head adjustment screws with hex key;
2. Securely attach light to wall;
3. Connect wiring;
4. Rotate light head to desired angle and tighten adjustment screws;

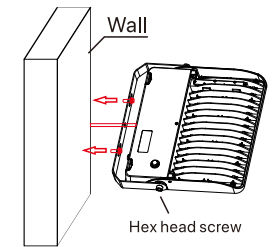

	<p>Black Wire - Line Voltage White Wire - Neutral Green Wire - Ground</p>
--	---

⚠ LIGHT MUST BE GROUNDED

