

HYPERLITE
www.hi-hyperlite.com

A good & brand new product. Congrats!
Enjoy brighter life now.

Feel free to contact us
Email: service@hi-hyperlite.com
Toll-free number: +1(855) 688 7879



LED FLOOD LIGHT

RELIABLE SOLID BRIGHT

FEATURES & SPECIFICATIONS

Model	FD03-30W	FD03-55W
Lumens	3900 LM	7150 LM
CCT	5000K	
CRI	>70	
Power	30W	55W
Life Span	>50,000 Hours	
Mounting	1/2"Knuckle	
Color	Dark Bronze	
Input Voltage	120-277V	
Power Factor	>0.9	
Operating Temperature	-40°C to -45°C(-40°F~113°F)	
IP rating	IP 65	
Warranty	5 Years	

READ THOROUGHLY BEFORE INSTALLATION

⚠ WARNING

- To prevent personal injury or product damage only licensed electricians should install.
- To avoid electric shock or component damage disconnect power before attempting installation or servicing.
- This product must be installed in accordance with the national electric code (NEC) and all applicable federal, state and local electric codes and safety standards.
- Disconnect product and allow cooling prior to servicing.
- Any alteration or modification of this product is expressly forbidden as it may cause serious personal injury, death, property damage and/or product malfunction.
- To prevent product malfunction and/or electrical shock this product must be properly grounded.
- This product must be installed in accordance with the applicable installation code by a person familiar with the construction and operation of the product and the hazards involved.
- This product is not available for several special environments, such as places with corrosive gas liquids or high pressure water vapor.

DIMENSION

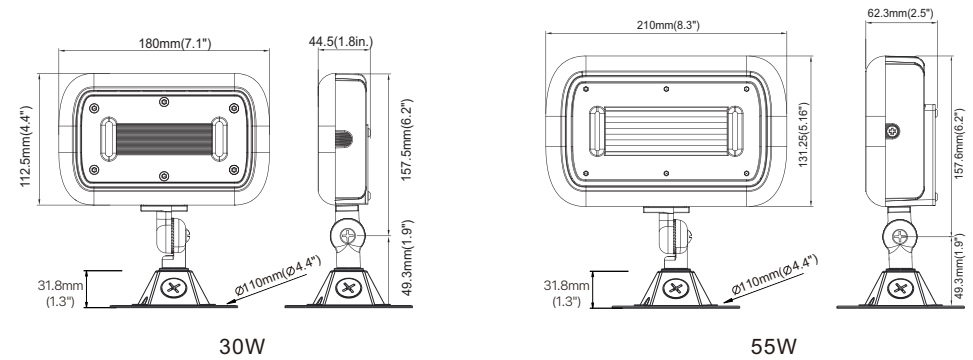

INSTALLATION INSTRUCTIONS

1/2" NPS Knuckle Mount

1. Install the fixture by knuckle bracket on the weatherproof Junction Box(supplied),and secure it by 1/2" locknut.
2. Make electrical connections from the supply ground (L/N/GND) lead to fixture ground(L/N/GND) lead respectively, making sure to follow all National Electrical Code and all applicable local codes and ordinances.
3. Aim fixture by loosening screw on knuckle of fitter and rotating fixture to desired tilt angle. Re-tighten screw.
4. While making electrical connections, ensuring water does not enter fixture through 1/2" fitter.
5. Installation and service of luminaires should be performed by a qualified licensed electrician.

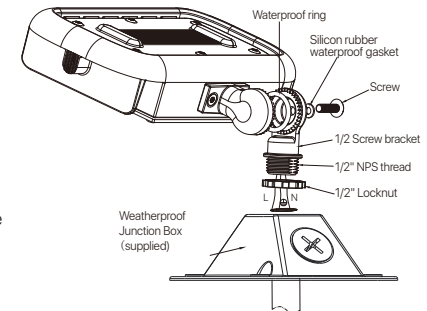

CAUTION: Seal the 1/2 " NPS thread using weatherproof silicone sealant while installing. This is especially important.

WIRE CONNECTION

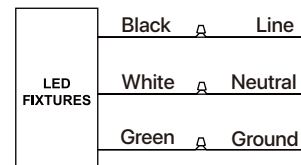

TROUBLESHOOTING

1. Check that the line voltage at the fixture is correct. Refer to wiring directions.
2. Is the fixture grounded properly.