



ZONE DAMPER

Model ZDS and ZDB

Installation Instructions



ZDB – Bottom Mount



ZDS – Side Mount

MINIMUM POSITION SETTING



The ZDs have a minimum position setting that allows the damper to remain open to a pre- set position instead of closing off fully. This minimum position provides for a small amount of air to be bypassed through the damper to lessen the need for a separate bypass damper and provide continual air circulation.

To set the minimum position, set when there is no power to the damper and it is in the open position. Loosen the long minimum position set screw and move to a desired setting shown on the minimum position label and re-tighten. When the damper is powered closed the minimum position screw will stop the damper at the position set.

NOTE: This label and screw does not indicate the position of the damper. It is only used to set the minimum position.

CHECKOUT

The ZD damper is a very simple damper to checkout. The two (2) wire spring return design simply requires a check for voltage at the motor when the damper is to be CLOSED. There must be 24 Volts AC, at the motor when the controller or switch provides power to the motor. When there is no power to the motor the damper will spring return back to its normally open position.

REPLACEMENT MOTOR

To replace the motor, loosen the locking set screw on the inside collar ring of the motor that holds the motor to the damper blade shaft, remove the motor and replace with the new motor. And re-tighten the set screw.

Bottom Mount Installation

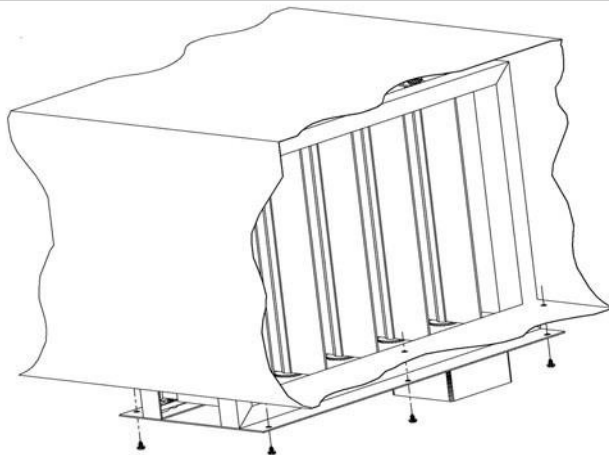

Side Mount Installation

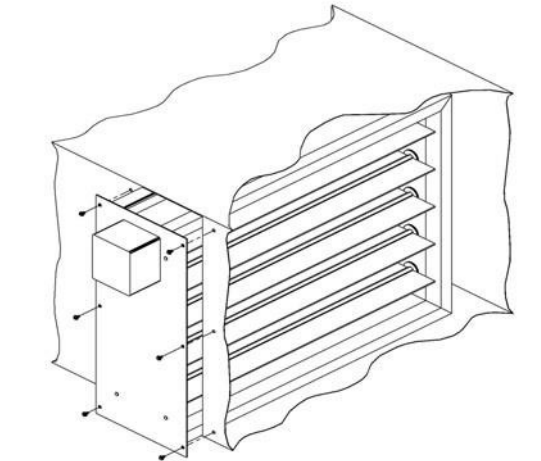

To install, Cut a 4" slot in the side of the duct the damper is to be inserted; Insert the damper and secure with sheet metal screws provided.

INSTALLATION

WHEN INSTALLING THIS PRODUCT...

Read these instructions carefully. Failure to follow the instructions could damage the product or cause a hazardous condition. Ensure that the installer is a trained, experienced service technician. After completing installation, use these instructions to check product operation.

LOCATION

The Zone Dampers are installed typically near the furnace/air handler plenum and in the air duct takeoff to the zone. Always make sure the dampers are accessible for wiring, checkout, duct cleaning and replacement of damper or motor if ever needed.

DAMPER SIZE

To ensure proper operation, the ZD must be properly sized for the air duct. To ensure proper fit, damper sizes are built slightly smaller. ¼" less than the listed dimensions. If the damper is forced into an undersized air duct, the excess pressure jams the damper blades and causes improper operation.

HUMIDIFICATION

Do not install dampers in heating systems where spray or atomizing type humidifiers are installed in the furnace plenum or air supply duct. Excessive lime or mineral deposits accumulate on damper blades and cause improper operation.

For humidification, use evaporative type humidifiers or return air type humidifiers.

INSTALLATION CONSIDERATIONS

Install Zone Dampers (ZDS) or (ZDB) in a square air duct. Frame misalignment may jam the damper blades. Do not weld dampers to air ducts.

INSTALLING A ZONE DAMPER

Ensure the ZD is correctly sized to the air duct and select a ZD location near the furnace plenum.

1. Cut a 4-inch (102-millimeter) opening in one side (shorter dimension) of the air duct at the location selected. Ensure the opening is cut fully to the top and bottom air duct seams.
2. Slide the ZDS into the cut opening of the air duct. Ensure the electric actuator is mounted toward the top of the air duct.
3. Secure the ZDS mounting plate to the air duct with the sheet metal zip screws provided.

CAUTION

Locate and install dampers in an easily accessible location for Service and Checkout.

Never force dampers into undersized air ducts. Excess pressure will jam damper blades.

Ensure high limit setting is 200qF (93qC) or lower. Higher settings can damage electric actuator.

WIRING

BEFORE WIRING – MAKE SURE ALL POWER IS DISCONNECTED TO PREVENT SHOCK AND EQUIPMENT DAMAGE.

ALL WIRING MUST CONFORM TO NEC STANDARDS AND ALL APPLICABLE LOCAL CODES.

The ZD damper is the simplest damper in the industry to wire. The ZD requires only two (2) wires for it 24 Volt AC, power-closed, spring return open operation.

The two wires from the motor wire to a normally open zone control panel to terminals M1 (Common) and M6 (Closed). See Wiring Diagram 1.

For other type of controls the two leads go direct to a 24 Volt power source and one of the motor leads is interrupted by a switch. See Wiring Diagram 2.

One 24VAC, 40VA Transformer can power up to five (5) damper motors.

To slave more than one motor together wire the motors in parallel. A total of five (5) motors should be on one 40VA transformer. When require more than five motors and isolation relay and additional transformers may be required.

WIRING DIAGRAM 1

M6/CLOSE
M4/OPEN
M1/COMMON

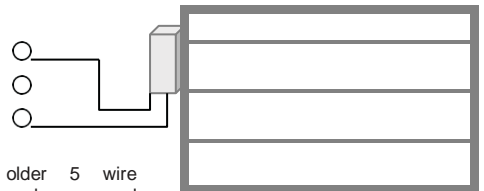

When replacing older 5 wire dampers, wire as shown and jumper M2-M5 terminals on control panel.

WIRING DIAGRAM 2

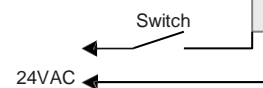

Converting from Power Closed to Power Open

Tools required – flat tip (3/16x7") screwdriver (magnetized or adhesive tape)

1. Set the damper on a flat surface with the motor on the top of damper.
2. Remove the motor and motor couplings using the flat tip screwdriver. Between the faceplate and the damper frame you will find the slotted set screw. Loosen and remove the set screw and the motor will slide off the damper blade shaft.
3. Position the damper so that you can see the damper blade linkage assembly (crankarms & drawbar), on opposite end of the damper motor. Note the position of the linkage assembly (crankarms @ approximately 1 0'clock position & drawbar to the right of the crankarms).
4. Remove linkage assembly by gently prying (use flat tip screwdriver) up on the base of the crankarm. The crankarm is attached to the damper blade bushing via a snap fitting. Disengage all of the crankarms from the blade bushings. **DO NOT REMOVE THE DRAW BAR FROM THE CRANKARMS.**
5. Rotate all of the blades counter clockwise (CCW) all the way to the CLOSED position.
6. Reattach/reposition the linkage assembly with the crankarms now positioned @ the 7 o'clock position and the draw bar positioned to the left of the crank arms. Once the linkage assembly is securely repositioned, manually rotate the blades open & closed to ensure blades move smoothly. Then position the blades CLOSED.

7. Reattach the motor. Ensure the damper blades are in tightly closed position. Slide the motor and the motor couplings back onto the blade shaft. Reinsert the set screw (may need to tape set screw to screwdriver for insertion into coupling) and tighten securely.

8. Apply power to motor to ensure damper powers open & springs closed.

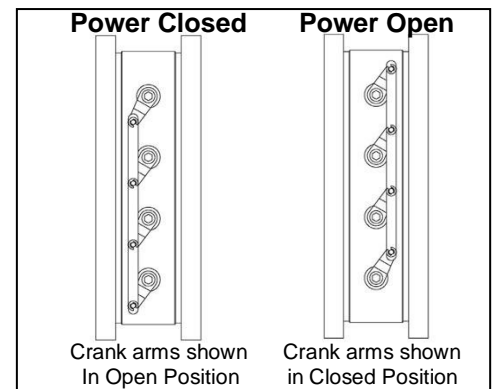

TECH TIP

Converting a ZD Damper (w/new snap in crank arms) from Power Closed to Power Open

Tools required: Flat tip (3/16 x 7") screwdriver (magnetized tip if available, if not available then will need 1" of any type of adhesive tape)

1. Place the damper on a flat surface, position the damper with the motor towards the top and to the right.
2. Remove the motor and motor couplings using the flat tip screwdriver. Between the faceplate and the damper frame you will find (ref photo #1) the slotted set screw. Loosen and remove the set screw and the motor will slide off the damper blade shaft.



Photo #1



Photo #2



Photo #3



Photo #4

3. Position the damper so that you can see the damper blade linkage assembly (crankarms & drawbar), on opposite end of the damper motor. Note the position of the linkage assembly (crankarms @ approximately 1 o'clock position & draw bar to the right of the crankarms, ref photo #3).
4. Remove linkage assembly by gently prying (use flat tip screwdriver) up on the base (ref photo #2) of the crankarm. The crankarm is attached to the damper blade bushing via a snap fitting. Disengage all of the crankarms from the blade bushings. **DO NOT REMOVE THE DRAW BAR FROM THE CRANKARMS.**
5. Rotate all of the blades counter clockwise (CCW) all the way to the **CLOSED** position.
6. Reattach/reposition the linkage assembly with the crankarms now positioned @ the 7 o'clock position and the draw bar positioned to the left of the crank arms, (ref photo #4). Once the linkage assembly is securely repositioned, manually rotate the blades open & close to ensure blades move smoothly. Position the blades **CLOSED**.
7. Reattach the motor. Ensure the damper blades are in tightly close position. Slide the motor and the motor couplings back on to the blade shaft. Reinsert the set screw (may need to tape set screw to screwdriver for insertion into coupling) and tighten securely.
8. Apply power to motor to ensure damper powers open & springs closed.