

# Manual of Solar Hot Water Pump Station SR11, SR21 Series



*Read the instruction carefully please before operation!*

## Content

|   |    |
|---|----|
| 1. Solar pump station with integrated controller .....                        | 2  |
| 1.1 Scope of delivery .....   | 2  |
| 1.2 About this manual .....   | 2  |
| 1.3 Safety instructions .....   | 2  |
| 1.4 Station dimensions .....  | 3  |
| 1.5 Specification of components .....   | 4  |
| 1.6 Technical Data: .....   | 5  |
| 2. Mounting of station .....  | 5  |
| 3. Commissioning of station.....  | 6  |
| 3.1 Flushing and filling the solar system .....                               | 7  |
| 3.2 Flow check .....  | 8  |
| 3.3 Manual /Auto in one airvent.....  | 8  |
| 3.4 Electrical connection of controller refer to the controller manual.....   | 9  |
| 4. Standard components of pump station SR11 single / SR21 double series ..... | 10 |

## 1. Solar pump station with integrated controller

- Integrated solar controller
- Outstanding design
- Safety assembly with safety valve and manometer
- High-Quality casing for reduce heat loses
- Flow rate check

### 1.1 Scope of delivery

- 1\* solar pump station
- 1\* integrated solar controller
- 1\* wall mounting bracket
- 1\* accessory bag
- 1\* manual

### 1.2 About this manual

This solar pump station is a preinstalled and leak-tested group of fitting for transferring heat from the collector to the store. It contains important fittings and safety devices for the operation of the solar thermal system:

- Ball valves in flow and return in combination with check valves to prevent gravity circulation.
- Airstopp for manual bleeding of the solar thermal system
- Flow rate check for displaying the flow rate
- Manometer for displaying the system pressure
- Safety valve to prevent inadmissible overpressure
- Flushing and filling unit (optional) for flushing, filling and emptying the solar thermal system.

### 1.3 Safety instructions

The installation and commissioning of the solar pump station as well as the connection of the electrical components requires technical knowledge commensurate with a recognized vocational qualification as a fitter for plumbing, heating and air conditioning technology, or a profession requiring a comparable level of knowledge. The following must be observed during installation and commissioning:



- The relevant regional and national regulations.
- The technical and safety instructions mentioned in this manual.



**Warning: risk of scalding**

There is danger of steam emission with safety valves. Therefore a discharge pipe must be connected to the safety assembly, please observe the enclosed instructions regarding the safety valve when doing this.



**Attention: damage of solar pump station**

- The group of fittings must be installed with sufficient spacing to the collectors because temperatures in the vicinity of the collectors can be very high. An intermediate vessel may be necessary for installation in the attic.
- It is imperative that you make sure the EPDM sealing elements of the solar pump station do not come into contact with substances containing mineral oil. Mineral oil products can cause lasting damage to the material, whereby its sealant properties are lost. If necessary, ask the manufacturer whether the solar fluid, fats or installation aids contain mineral oils. We don't assume liability nor provide warranty for damage to solar station resulting from sealants damaged in this way.

**1.4 Station dimensions**

- Height ( with insulation): 450mm
- Width (with insulation): 300mm
- Depth (with insulation): 158mm
- Distance center: 1600mm
- Distance axis/wall: 55mm
- Pipe connections: 3/4' IT( inner thread)
- Connection for expansion vessel set: 3/4'ET,
- Outlet safety valve: 1/2 IT

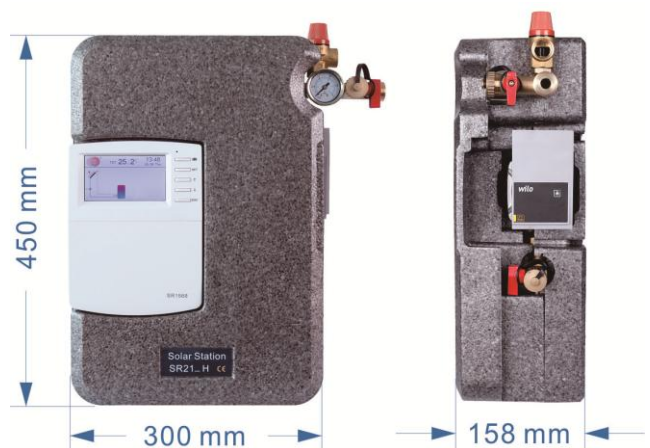

## 1.5 Specification of components

- 1) Non-return valve: opening pressure 200mm H<sub>2</sub>O
- 2) Collector return connection: 3/4 female thread
- 3) Safety valve: 6bar
- 4) Filling valve connection
- 5) Connection of expansion vessel: 3/4 male thread
- 6) Manometer: 0-6bar
- 7) Sensor on tank return pipe: NTC10K, B=3950
- 8) Circuit pump: different brand and type available
- 9) Drainage valve connection
- 10) Grundfos flow rotor VFS or fixed flowmeter
- 11) Tank return pipe connection (from tank) : 3/4 male thread
- 12) Tank flow pipe connection( to tank ) : 3/4 female thread (no this component in single pipe pump station SR11)
- 13) Integrated solar controller (different models available)
- 14) Bubble air vent valve (no this component in single pipe pump station SR11)
- 15) Temperature sensor of collector flow: NTC10K, B=3950 (no this component in single pipe pump station SR11)
- 16) Collector flow connection (to collector):3/4' IT female thread (no this component in single pipe pump station SR11)

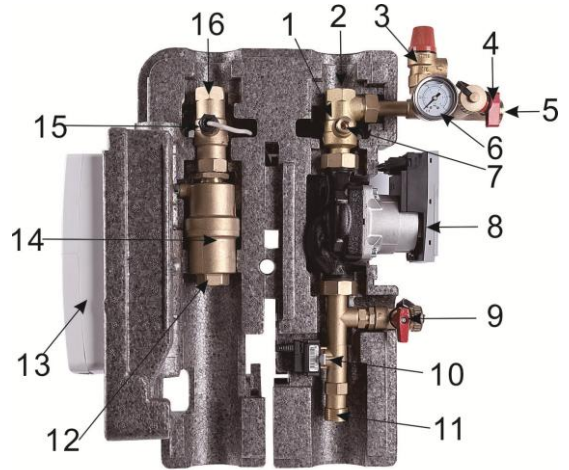

### Material of pump station:

- Fitting: brass
- Seals: PTFE
- Insulation: EPP,  $\lambda = 0.041 \text{ W / (m.K)}$

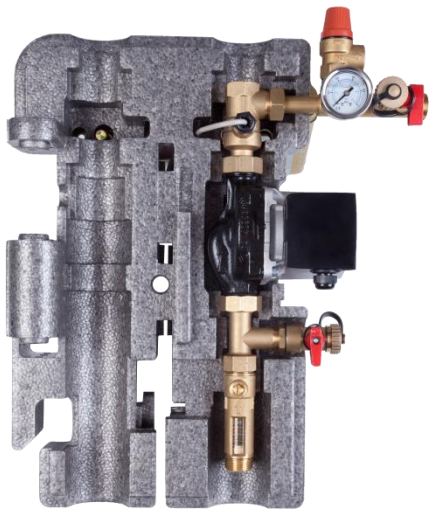

SR11series single pipe station

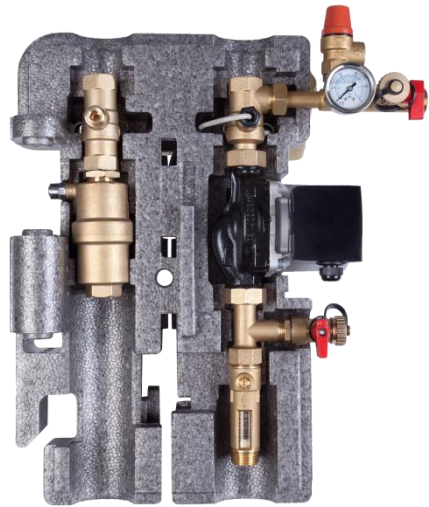

SR21series double pipes station

### 1.6 Technical Data:

- Max. permitted pressure: 6bar
- Max. permitted operating temperature: 120°C
- Grundfos flow rotor VFS: 0.1-20L/Min
- Mechanical flow rate: 2-8L/Min

### 2. Mounting of station

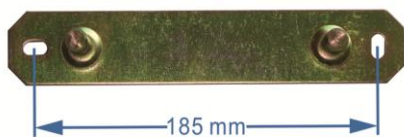

Distance center of bracket: 185mm

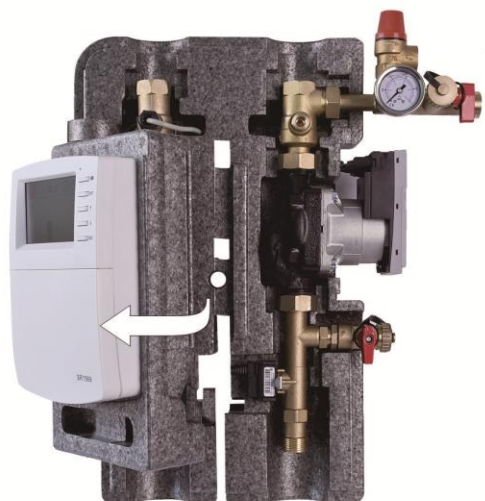

- Determine the mounting site of the station.
- Take the station out of packing; Remove the front half of the insulation.
- Hold the enclosed wall mounting bracket against the wall and mark the fastening holes, drill holes and insert dowels.
- Fasten the wall mounting bracket to the wall with the screws.
- Push the station against the wall mounting bracket, the station catches and is then attached to the wall.
- Connect the station to the solar thermal system.
- Check the inlet pressure of the expansion vessel and if necessary, adjust it to the local conditions,  $P_{inlet}(\text{bar}) = 1\text{bar} + \Delta Th(\text{m}) * 1/10$  ( $\Delta Th$ =height difference between collector and station) .
- Connect the electrical components of the solar station, Attach the store and collector sensor and connect them to the controller, plug the controller into the socket.
- Tighten all union nuts and screw connections.
- Attach the front half of the insulation to the station.

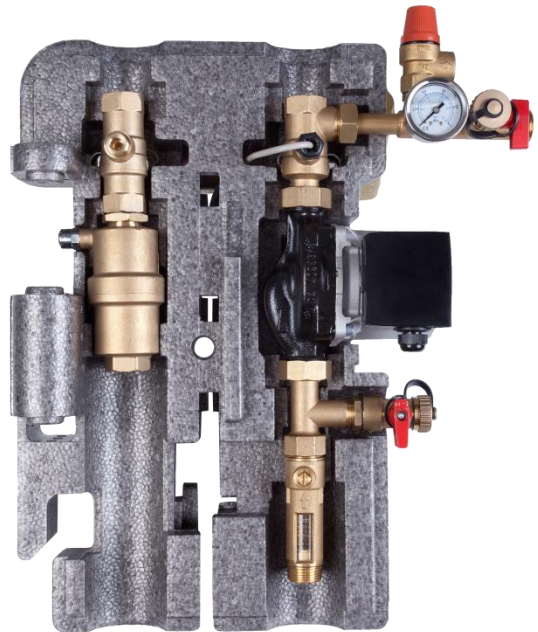

### 3. Commissioning of station



#### **Attention: Risk of scalding!**

In order to prevent the boiling of solar fluid in the collectors, the system should not be flushed or filled during periods of strong sunshine.



#### **Attention: Risk of frost!**

Solar thermal system cannot be completely emptied after flushing. There is a danger of frost damage if water is used for flushing. Only use solar fluid to flush and fill the solar thermal system. Use water - propylene glycol mixture as solar fluid

(Maximum 50% propylene glycol).

### 3.1 Flushing and filling the solar system

Flushing and filling unit is already integrated in the solar pump station, but we still recommend to install flushing and filling ball valve at the lowest point of the solar circuit in order to drain off the scales.

#### Flushing and filling steps:

- Disconnect the expansion vessel from the solar thermal system.
- Connect the pressure hose of a flushing and filling station to the fill ball valve (5) of flushing and filling unit.
- Connect the flushing hose of a flushing and filling station to the drain ball valve (9) of flushing and filling unit.
- Open the filling ball valve (5) and drain ball valve (9).
- Flush the solar thermal system using the flushing and filling station for at least 15 minutes to remove all air from the system.
- During the flushing, bleed the solar thermal system several times at the airstopp until the discharged solar fluid is free of air bubbles.
- Close the drain ball valve(9) of flushing and filling unit, and continues run the pump and increase the system pressure to approx.5 bar, system pressure can be read from the manometer.
- Close the filling ball valve (5) of the flushing and filling unit, and then close the filling pump.
- Check the manometer to see whether the system pressure reduces and eliminate leaks where necessary.
- Reconnect the expansion vessel to the solar thermal system.

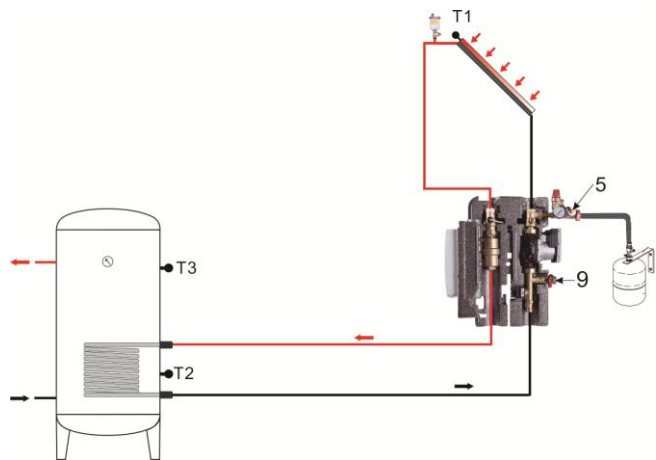



### 3.2 Flow check

The flow counter is used for measurement and display of flow rate, in order to guarantee the flawless function of the measuring device the system must be flushed and free from foreign substances.



Grundfos flow rotor VFT

(VFS 1-12, VFS 2-40 selectable)

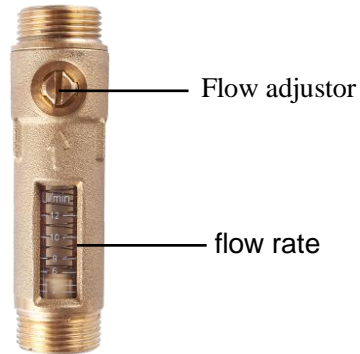

Mechanical flow meter (2-12L/min)

### 3.3 Manual /Auto in one airvent

After system is filled and commissioned, air vent will automatically release the air of system, but you can also release the air manually.

- Air vent valve factory is set to the automatically position.
- If valve is at the automatically position, then anticlockwise rotates 180 to change the vent status to manual vent position (figure 1).
- If valve is at the manual position, clockwise rotates 180 to change the vent status to automatically vent position (figure 2).
- Manual vent position is used to release the air, which is resolved from the solar liquid and gather at the air vent (figure 3), in order to release air successfully, please ensure the flow speed of system to be 0.3m/s at least.
- After air release, please check the system pressure, if necessary to increase the pressure to the specified operation pressure.

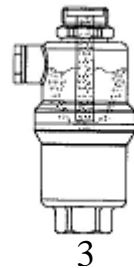
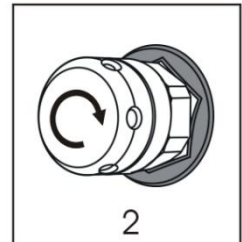
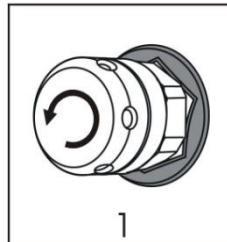



**Warning: Risk of scalding!**

During air releasing, temperature of discharged air or liquid might than 100°C.

### 3.4 Electrical connection of controller refer to the controller manual



**Warning:** disconnect the controller from power supply before opening the housing!

The controller is already integrated within the station, plug in installation. For maintenance or service work, it needs to be removed the controller from station, following below steps:

- Switch off the system, disconnect plug from the mains.
- Remove the front half of the insulation.
- Unscrew the cross-recessed screw of the front cover of controller and remove it by pulling it downwards.
- Unscrew the cross-recessed screw of lower part of controller and remove it by pulling it upwards.
- Doing reverse steps to remount the controller.



**Note:** For further information on electrical connection of the controller, please see manual of equipped controller (terminal layout).

#### 4. Standard components of pump station SR11 single / SR21 double series

| Components   | Models | SR11_L | SR11_M | SR11_H |
|--|--------|--------|--------|--------|
|  |        | SR21_L | SR21_M | SR21_H |
| Controller: SR258  |        | √      |        |        |
| Controller: SR658  |        |        | √      |        |
| Controller: SR1568   |        |        |        | √      |
| Convention Pump: Wilo: RS15-6 or ST-ECO15-6<br>Grundfos: SOLAR15-65            |        | √      | √      |        |
| High efficiency pump:<br>Wilo YONOS PARS ST17/7.0 PMWM2<br>Grundfos UPM3 SOLAR |        |        |        | √      |
| Grundfos flow rotor VFS  |        |        |        | √      |
| Germany AFRISO fixed flowmeter   |        | √      | √      |        |



**Note:** it is possible to equip with the customized controller, pump, and flowmeter for above mentioned models of solar pump station.