



---

## TITANIUM SHELL AND TUBES HEAT EXCHANGERS FOR SWIMMING POOLS AND SPAS

---



## Table of Contents

Introduction .....	3
Mounting .....	3
Horizontal Mounting .....	3
Installation Instructions .....	5
Operation instructions .....	5
Quick selection of Titanium pool & spa heat exchangers .....	6
Note: .....	6
WARNING.....	7
IMPORTANT !!!.....	7



## Introduction

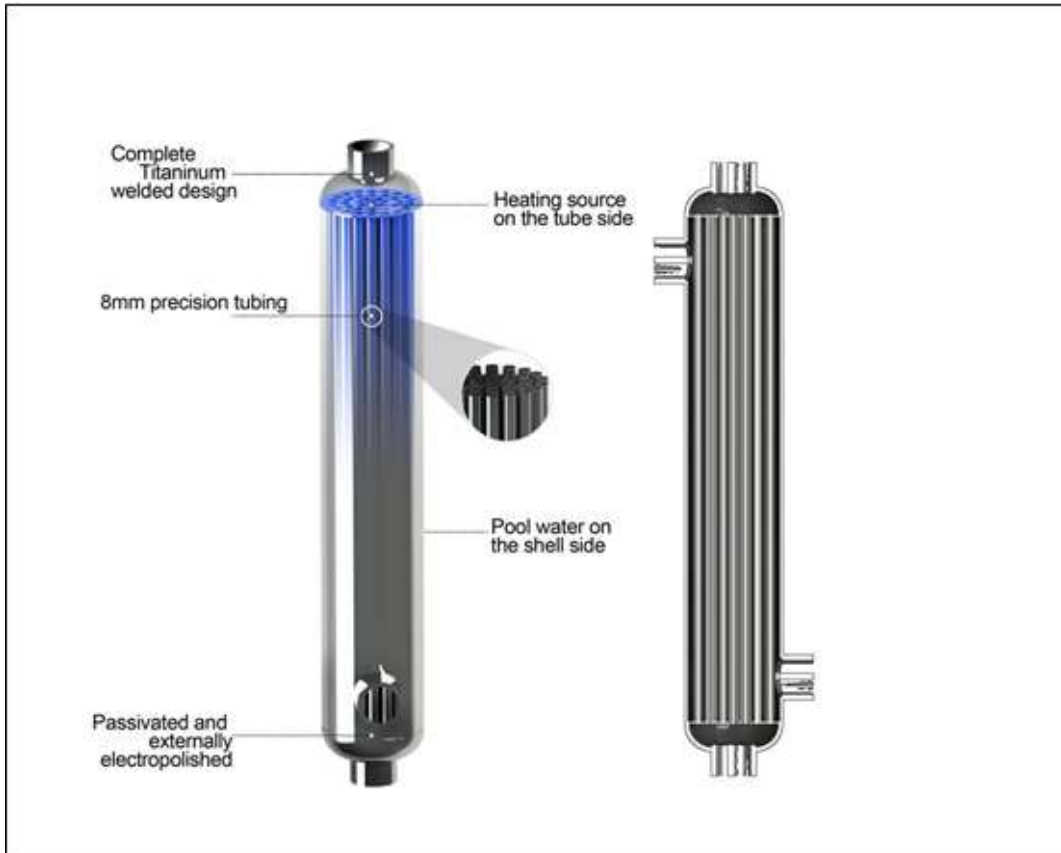

Our heat exchanger fully constructed of titanium shell and Titanium tubes making Titanium Pool & Spa Heat Exchanger a very reliable and effective way transfer heat indirectly between any Heat Source (such as boiler, Air to Water Heat Pump, Geothermal Heat Pump, Solar Thermal Panels, etc.....) and pool or spa circuit.

## Mounting

Heat Exchangers are designed for both horizontal and vertical mounting, it is recommended to always install the unit with a mounting bracket (supplied with the unit) fixed to a wall, or ceiling or floor to prevent Water Hammer Dampers or Vibrations which could damage the unit. The use of expansion joints on the boiler circuit is recommended.

### Horizontal Mounting

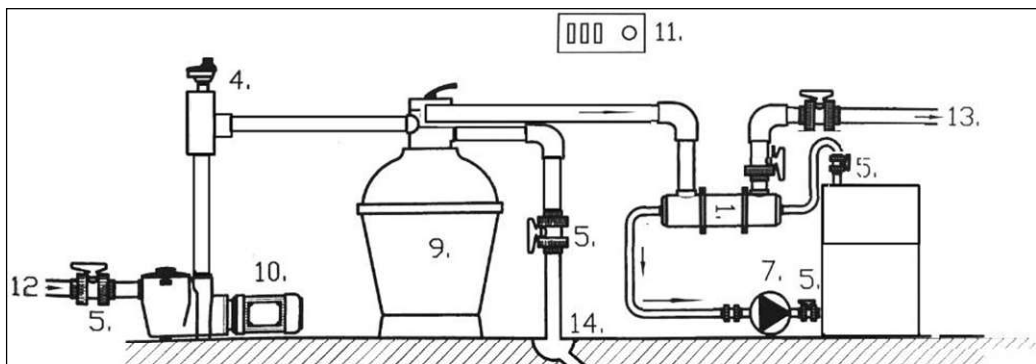



### Vertical Mounting

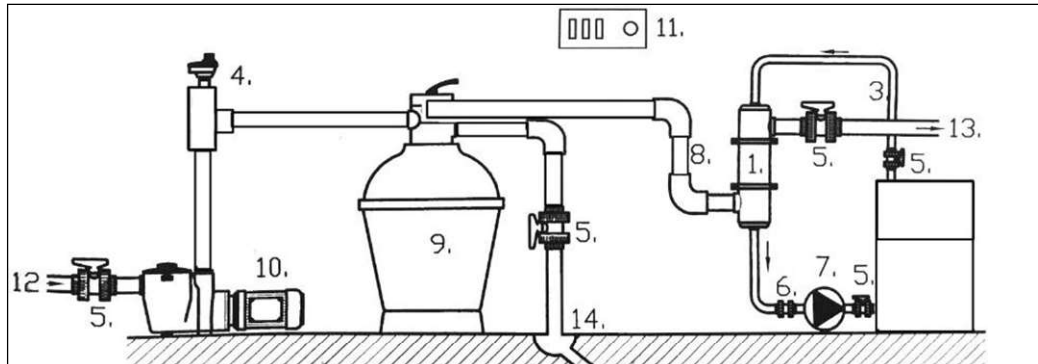

1. Heat Exchanger
2. Heat sources such as Boiler, Solar panels, or heat pump
3. Primary hot water circuit
4. Thermostat
5. Gate valve
6. Check Valve
7. Primary Circulation Pump
8. Secondary circuit (Pool water)
9. Filter
10. Secondary Circulation Pump
11. Control panel
12. From pool or SPA
13. Return to pool or SPA
14. Drain



## Installation Instructions

Important: Always install the pool & Spa heat exchanger in a counter flow pattern, as shown in the following figure.

Pool & spa heat exchangers should be installed downstream of the filtration and pumping equipment. Heat

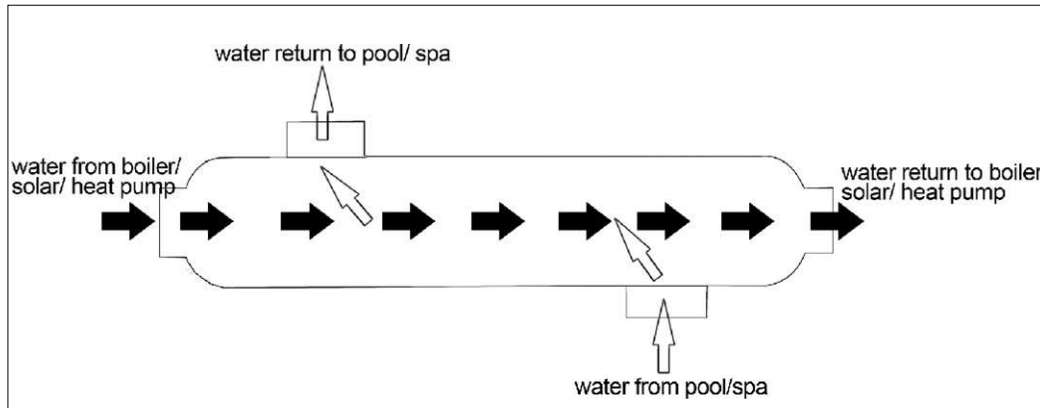

Source (Boiler, Heat Pump, Solar thermal, etc...) water must be pumped and purged, and precautions taken to prevent air traps within the primary piping loop. The pool water pump should be controlled by the thermostat in the pool pipe work before the heat exchanger and set point adjusted to the required temperature.

## Operation instructions

It is important that these instructions are followed to prevent any corrosion or erosion of Titanium pool & spa heat exchanger.

- A. Operate the unit under the following design parameters shell/tube side pressure: 6 bar (87 psi), Temperature: -5°C (23°F)-200°C (392°F)
- B. Install unit before chlorination device.
- C. Start-up
  - Valves should be opened gradually to achieve a steady increase in flow and pressure into the unit.
  - The cold side (heated) fluid should first enter the system.
  - The hot side (heat source) fluid, water or steam, should be gradually brought into the system.
  - Check all connections for leakages.
- D. Shut Down: shut down hot fluid side first, then the cold fluid side.
- E. Always keep PH within correct levels. The ideal pool PH should be kept between 7-8. It is extremely important to avoid PH to fall below 7.2 or above 7.8. you must check on a daily basis. Modify your pool condition if necessary.
- F. You must ensure that the chlorine levels are in the range recommended by your pool chemicals supplier and they are aligned to your specific needs.
- G. If you have installed a by-pass fitted to the heat exchanger circuit, it is important that any valve is correctly positioned and balanced to allow the recommended pool water flow to circulate through the heat exchanger unit.
- H. The filter should be checked regularly, especially sand filters, this type of filtration if working improperly will allow sand to pass around the pool circuit causing erosion of the heat exchanger and other components of the system as well.
- I. It is important that the correct chlorine dosage is added to the pool. To allow proper dispersion of this chemical into the pool, spread it evenly on the surface, do not drop chlorine dosage in one area only as this will create highly acidic areas which can cause irreversible damage to the heat exchanger.
- J. Keep pool free from leaves and other debris, all organic matter can decay and increase the pool PH causing



damage the unit.

K. It is important to winterize properly if the pool is exposed to winter conditions, we recommended fully draining down the heat exchanger or removing it completely from the installation though the duration of the shutdown period, otherwise icing the unit would damage the heat exchanger.

L. Always choose harmless cleaning liquids if needed and clean carefully.

M. Chlorinator should be in optimal working conditions.

### Quick selection of Titanium pool & spa heat exchangers

Model for USA	Model other countries	Nominal Capacity		Pool Capacity	
		KW	KBTU/H	m <sup>3</sup>	USGAL
ST55	ST16	16	55	15	3,960
ST85	ST25	25	85	25	6,600
ST155	ST45	45	155	45	11,900
ST210	ST60	60	210	65	17,200
ST300	ST88	88	300	90	23,800
ST360	ST105	105	360	110	29,000
ST600	ST175	175	600	180	47,500
ST1200	ST352	352	1200	360	95,100

**Note:**

1. For occasional (holidays & weekends) use pools we recommend a 2X output multiplier to obtain 2°C/h (2°F/h) heat up rate.
2. Nominal values are based on 60°C temperature between incoming heating and heated water.



### **WARNING**

The following fluids are prohibited for use as a flushing agent for Titanium pool & spa heat exchangers.

- Hydrochloric acid up to 0.1% concentration
- Solutions that contain MCI
- Chlorides (MgCl<sub>2</sub>, NaCl between 0.01-1%, CuCl up to 1%, CaCl<sub>2</sub> from 5% to saturation)
- Any fluid that will deposit alkaline residue or phosphorous.

### **IMPORTANT !!!**

IT IS PURCHASER'S RESPONSIBILITY TO ENSURE THAT ALL FLUIDS IN CONTACT WITH THE PRODUCTS ARE COMPATIBLE WITH THE CONSTRUCTION MATERIAL OF THE PRODUCT. THIS INCLUDES OPERATIONAL FLUIDS AND CLEANING FLUIDS. CORROSIVE ENVIRONMENTS ARE OFTEN A COMBINATION OF CHEMICAL LEVELS, FLOW RATES, AND TEMPERATURES. FAILURE TO ENSURE THIS WILL RESULT IN DAMAGES TO THE PRODUCT.

IF ANY OF ABOVE CONDITIONS IS NOT FULLY COMPLIED THE WARRANTY OF THIS UNIT IS VOID.

Technical or commercial considerations may, from time to time to alter the design, performance and dimensions of the equipment and the right is reserved to making such changes without previous notice.