

# CBIT500L2C40 - 500L SOLAR WATER TANK WITH TWO INDIRECT COIL

## TECHNICAL SPECIFICATIONS :

**Inner Tank Materials:** Food Grade Stainless steel SUS 304 1.8mm (0.07") thickness.

**Outer Tank Cover Material:** Color steel plate , thickness:0.5mm

**Thermal Insulation Layer:** 60 mm (2") of High Pressure Automatic Polyurethane Foaming Layer, Density of 36 Kg/m<sup>3</sup> (2.24 Lb/ft<sup>3</sup>).

**In Tank Heat Exchangers (Coils) Specifications:** SS304 (Stainless Steel), Thickness = 1mm (0.04").

**Immersed Coil Outer Diameter :** 38mm (1.5") , Coil Inlet/Outlet Connection: 38mm (1.5") Female NPT..

**Bottom Coil Heat Exchange Area :** 3 m<sup>2</sup>(32.29 ft<sup>2</sup>).

**Upper Coil Heat Exchange Area :** 1.7 m<sup>2</sup>(18.29 ft<sup>2</sup>).

**Water Purification:** Magnesium Rod Installed

**Backup Heat:** Standard 1" port for electric backup with mechanical thermostat (Heater not included with the tank)

**Accessories:** Tank Feet, Screws, Safety T/P Valve and Drain Valve Port Plugged.

**HSE Limited Warranty:** 5 Years against manufacturing defects.

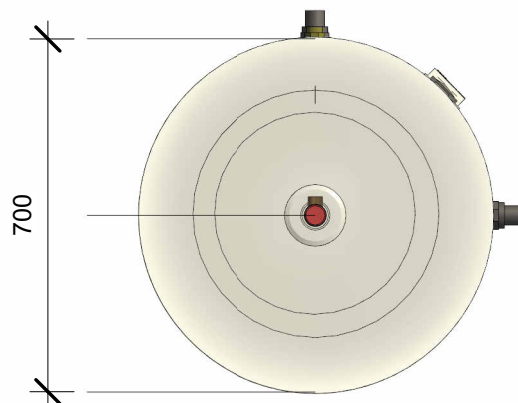

# CBIT500L2C40 - 500L SOLAR WATER TANK WITH TWO INDIRECT COIL

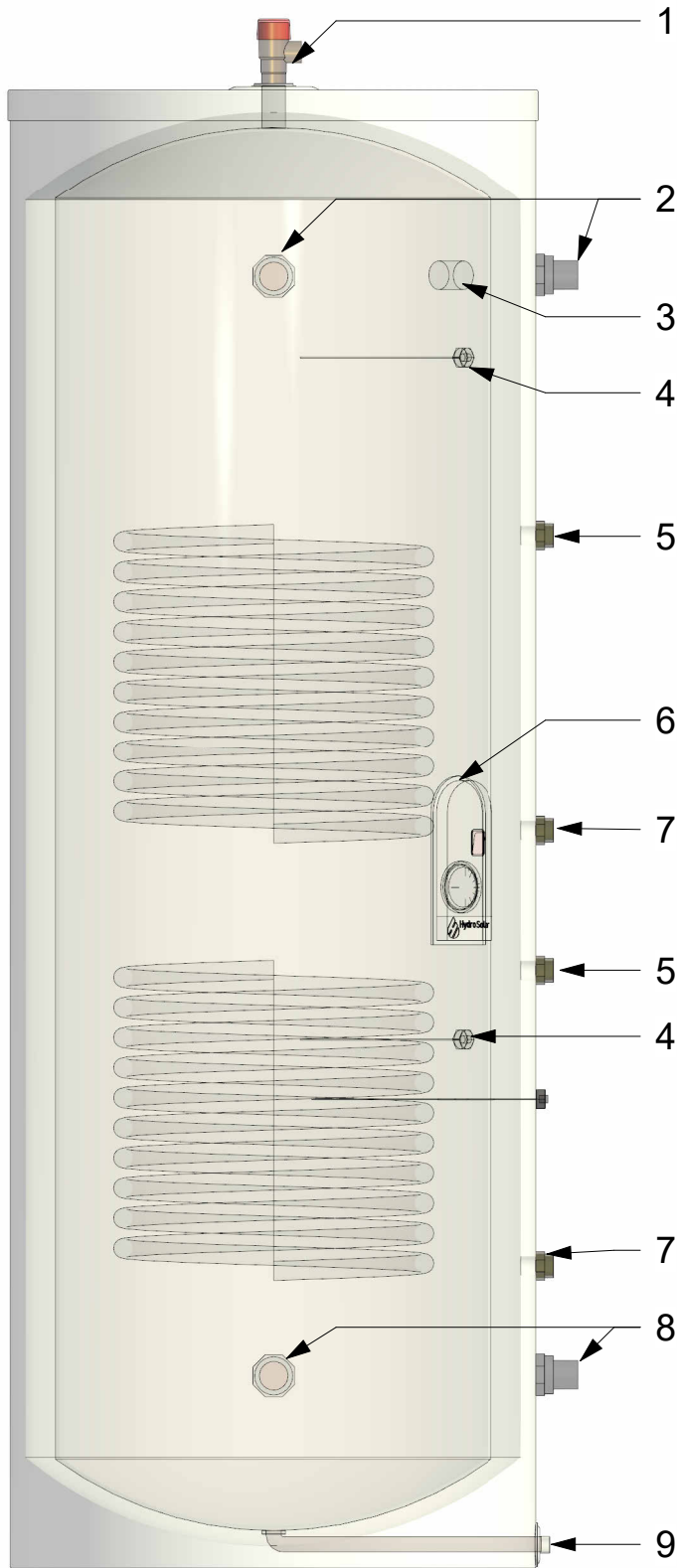

1	T/P SAFETY VALVE PORT 3/4" FEMALE (SAFETY VALVE PACKED INSIDE SHIPPING BOX)
2	WATER TANK INLET/OUTLET FEMALE 2" NPT
3	MAGNESIUM ROD 3/4" BSPT FEMALE
4	TANK TEMPERATURE SENSOR PORT 1/2"-3/4" BSPT FEMALE
5	IMMERSED COIL 1.5" FEMALE NPT OUTLET
6	ELECTRIC HEATING ELEMENT 1" FEMALE PORT (HEATING ELEMENT NOT INCLUDED)
7	IMMERSED COIL 1.5" FEMALE NPT INLET
8	WATER TANK INLET/OUTLET FEMALE 2" NPT
9	DRAINAGE 3/4" NPT FEMALE THREADED PORT WITH MALE 3/4" NPT END CAP

GROSS WEIGHT: 100KG (220.46)

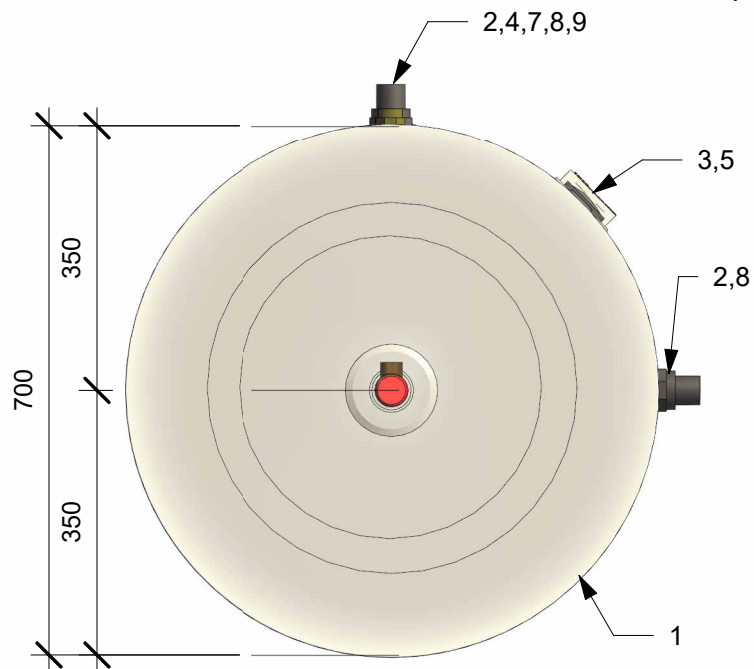

# CBIT500L2C40 - 500L SOLAR WATER TANK WITH TWO INDIRECT COIL

