

CBIT200L1C40 - 200L SOLAR WATER TANK WITH TWO INDIRECT COIL

TECHNICAL SPECIFICATIONS :

Inner Tank Materials: Food Grade Stainless steel SUS304 , 1.2mm (0.05") thickness.

Outer Tank Cover Material: Color steel plate , thickness:0.5mm

Thermal Insulation Layer: 60 mm (2") of High Pressure Automatic Polyurethane Foaming Layer, Density of 36 Kg/m³ (2.24 Lb/ft³).

In Tank Heat Exchangers (Coils) Specifications: SS304 (Stainless Steel), Thickness = 1mm (0.04")..

Immersed Coil Outer Diameter : 38mm (1.5") , Coil Inlet/Outlet Connection: 38mm (1.5") Female NPT.

Bottom Coil Heat Exchange Area : 2 m²(21.52 ft²).

Upper Coil Heat Exchange Area : 1m²(10.76 ft²).

Water Purification: Magnesium Rod Installed

Backup Heat: Standard 1" port for electric backup with mechanical thermostat (Heater not included with the tank)

Accessories: Tank Feet, Screws, Safety T/P Valve and Drain Valve Port Plugged.

HSE Limited Warranty: 5 Years against manufacturing defects.

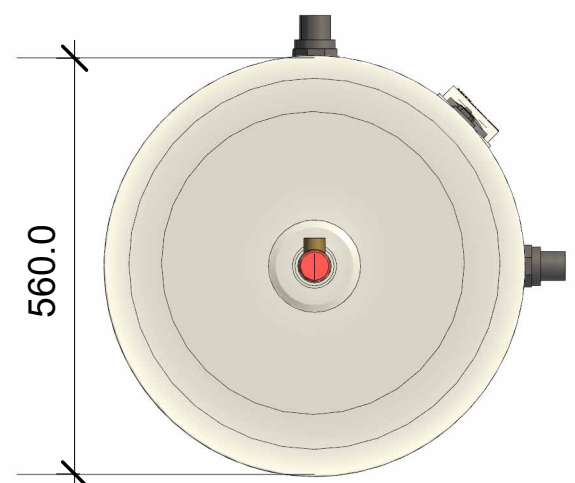

CBIT200L1C40 - 200L SOLAR WATER TANK WITH TWO INDIRECT COIL

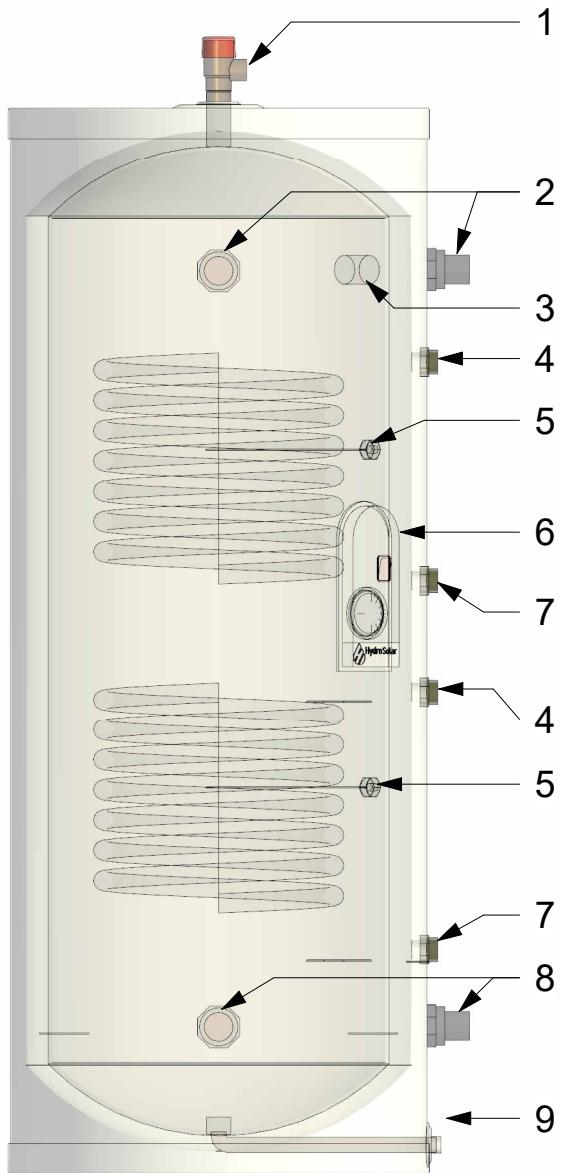

1	T/P SAFETY VALVE PORT 3/4" FEMALE (SAFETY VALVE PACKED INSIDE SHIPPING BOX)
2	WATER TANK INLET/OUTLET FEMALE 1.5" NPT
3	MAGNESIUM ROD 3/4" BSPT FEMALE
4	IMMERSED COIL 1.5 FEMALE NPT OUTLET
5	TANK TEMPERATURE SENSOR PORT 1/2"-3/4" BSPT FEMALE
6	ELECTRIC HEATING ELEMENT 1" FEMALE PORT (HEATING ELEMENT NOT INCLUDED)
7	IMMERSED COIL 1.5" FEMALE NPT INLET
8	WATER TANK INLET/OUTLET FEMALE 1.5" NPT
9	DRAINAGE 3/4" NPT FEMALE THREADED PORT WITH MALE 3/4" NPT END CAP

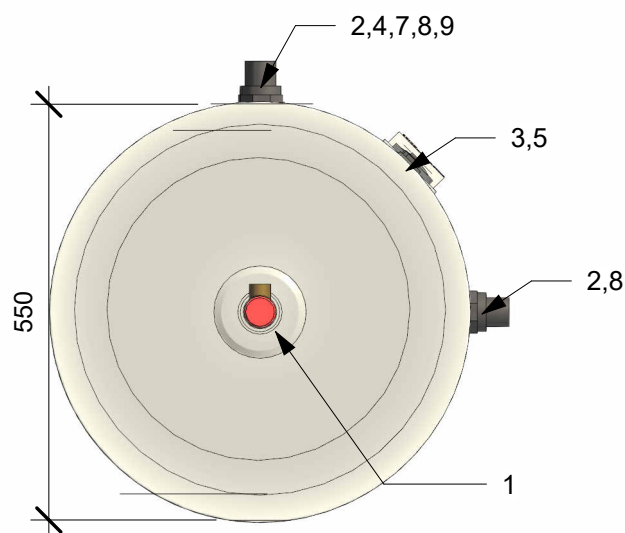

GROSS WEIGHT: 55 KG (121.25 LB)

CBIT200L1C40 - 200L SOLAR WATER TANK WITH TWO INDIRECT COIL

