



Engineering Specification

ATW-45-HACW-P-*T-* Air to Water Heat Pump 60 Hz



Maritime Geothermal Ltd.
P.O. Box 2555, 170 Plantation Road
Petitcodiac, NB E4Z 6H4
(506) 756-8135

info@nordicghp.com
www.nordicghp.com
001848SPC-02

Model Nomenclature

Indoor Unit:

ATW - 45 - HACW - P - 1T - C - xx

Series:

ATW = Air To Water

Nominal Size:

45 = 030 compressor

Function:

H = Heating
AC = Active Cooling
W = domestic hot Water

Refrigerant:

P = R410a

Revision:

01, 02, etc.

Indoor Coil:

C = Copper coaxial
Y = Cupro-Nickel coax & piping
Z = Cupro-Nickel coax only

Compressor:

T = 2 stage scroll

Voltage Code:

1 = 208/230-1-60
2 = 208-3-60
4 = 460-3-60

APPLICATION TABLE										
SERIES	SIZE	FUNCTION	REFRIGERANT	VOLTAGE	COMPRESSOR	INDOOR COIL	REVISIONS			
ATW	45	HACW	P	1 2 4	T	C Y Z	02			

Matching Outdoor Unit:

ACE - 45 - P - 1/6 - SDE - xx

Series:

ACE = All weather Condenser / Evaporator

Nominal Size:

45 = matched to size 45 indoor unit

Refrigerant:

P = R410a

Revision:

01, 02, etc.

Fan:

D = Direct Drive
E = EC motor

Air Coil:

S = Standard
K = Coated

Voltage Code:

1/6 = 208/230-1-60 or
220-1-50

APPLICATION TABLE										
SERIES	SIZE	REFRIGERANT	VOLTAGE	AIR COIL	FAN	REVISIONS				
ACE	45	P	1/6	S K	DE	03				

Maritime Geothermal Ltd. has a continuous improvement policy and reserves the right to modify specification data at any time without prior notice .

Design Features

- TUV listed for electrical certification
- 18/20ga satin galvanized cabinet with reinforcing channel stiffeners
- Powder coat finish
- Acoustically insulated cabinet (1" and 1/2" thick)
- Completely insulated heat exchanger and piping
- Four removable access panels
- Refrigeration service ports located inside unit (1/4" Schrader)
- Swing out electrical box for unobstructed access to compressor
- Component layout allows easy access for service
- 1" Brass FPT fittings for hydronic connections
- Copeland Ultratech scroll compressor with start capacitor kit on single phase models
- Dual grommet mounting system for compressor reduces noise and vibration
- Suction line accumulator for compressor protection
- Liquid line filter-dryer & sight glass
- Two Electronic Expansion Valves (EEVs)
- Coaxial hydronic heat exchanger, available in CuNi
- High and low pressure sensors
- Manual reset high pressure control
- Suction line temperature sensor
- Temperature sensors on both water lines
- Control transformer with resettable breaker or fuse protection
- Advanced control board with BACNet interface for remote operation and data access including all sensor data and alarm conditions, PWM outputs (or 0-10VDC), configurable analog inputs (0-5VDC or 4-20mA) with onboard 5VDC, 12VDC and 24VDC power supplies.
- USB port for complete data access including real-time charting, data logging, and diagnostic functionality with manual override operation
- 2 x 16 LCD display for control and data access; unit may be configured for standalone operation with outdoor reset functionality (requires outdoor temperature sensor accessory)
- Random start on power up (0-2 minutes)
- 24VAC output and dry contacts for auxiliary heat, controlled by ATW

- Double wall Domestic Hot Water desuperheater suitable for potable water connections.
- Brass head ECM circulator for domestic hot water circuit uses less than half the power of traditional circulating pumps and allows motor replacement without tools
- 1/2" brass FPT fittings for Domestic Hot Water connections

Available Accessories

- Hydronic buffer tank with 12, 15, or 20kW of electric backup elements
- Barbed P/T port adapters for heat pump
- Anti-vibration pad for under unit
- Compressor sound jacket
- Secure Start module
- CuNi heat exchanger
- Compressor current sensor

Design Features - Indoor Unit

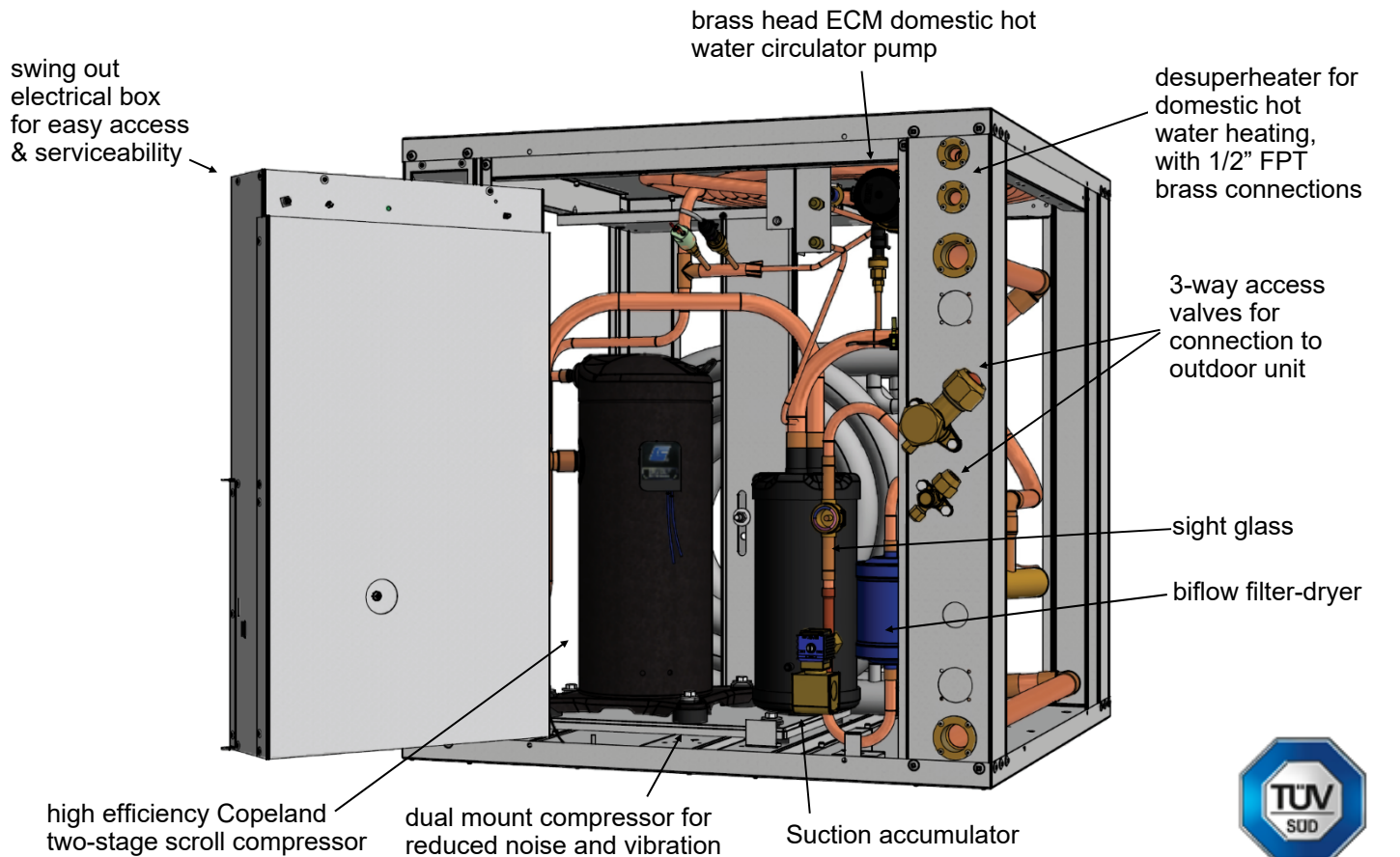
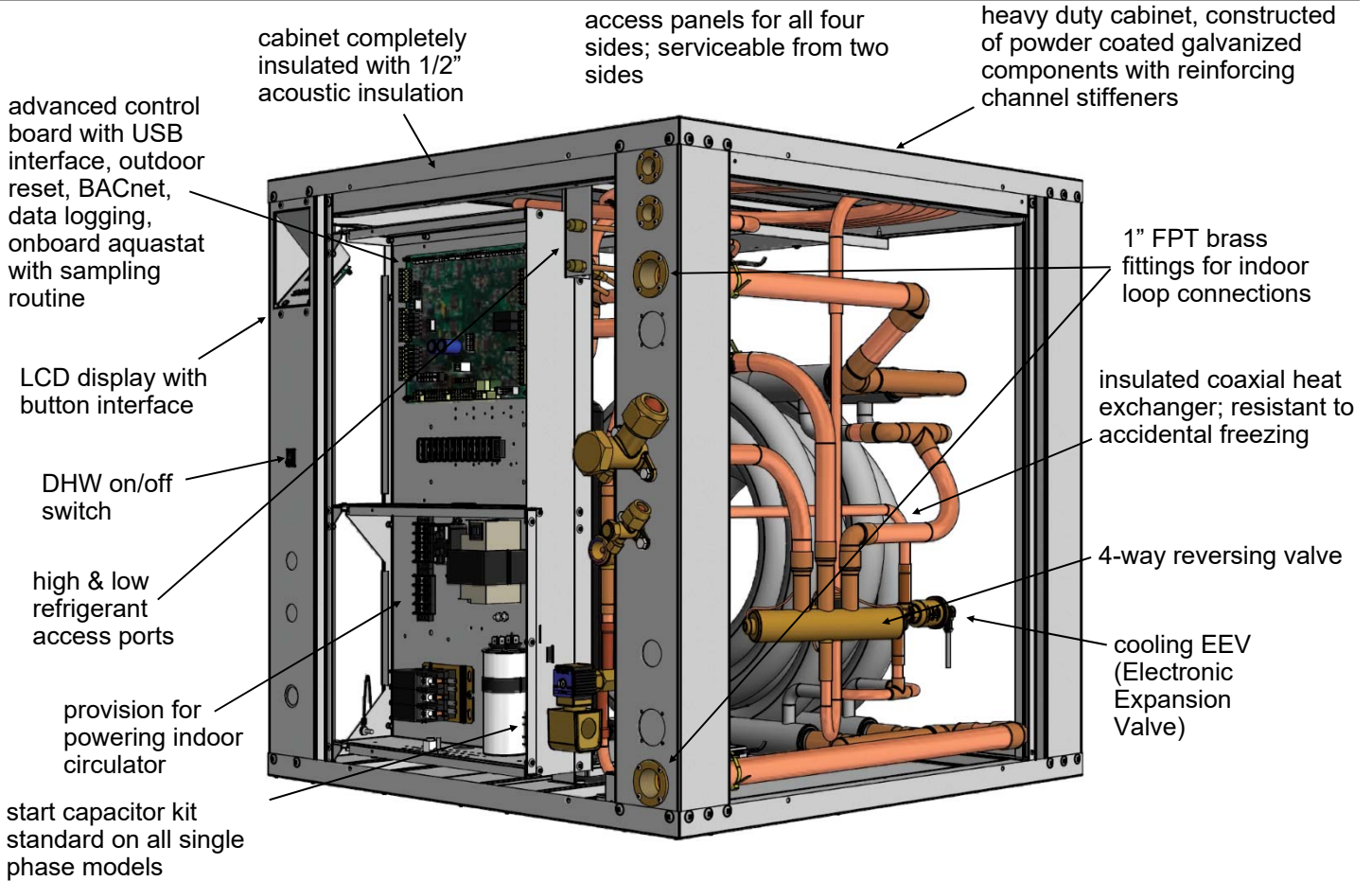

Design Features - Outdoor Unit

minimal components in outdoor unit, for maximum component life and ease of service

electrical box contains only connection terminal strips

side cover protects refrigerant pipes & wiring connection point

visor protects motor from water ingress and immobilization from freezing

EC (electronically commutated) fan hub motor, for full variable speed operation and maximum energy efficiency

heavy duty cabinet, constructed of powder coated galvanized components

mounting grommets for vibration isolation

swing out fan panel for easy access & serviceability

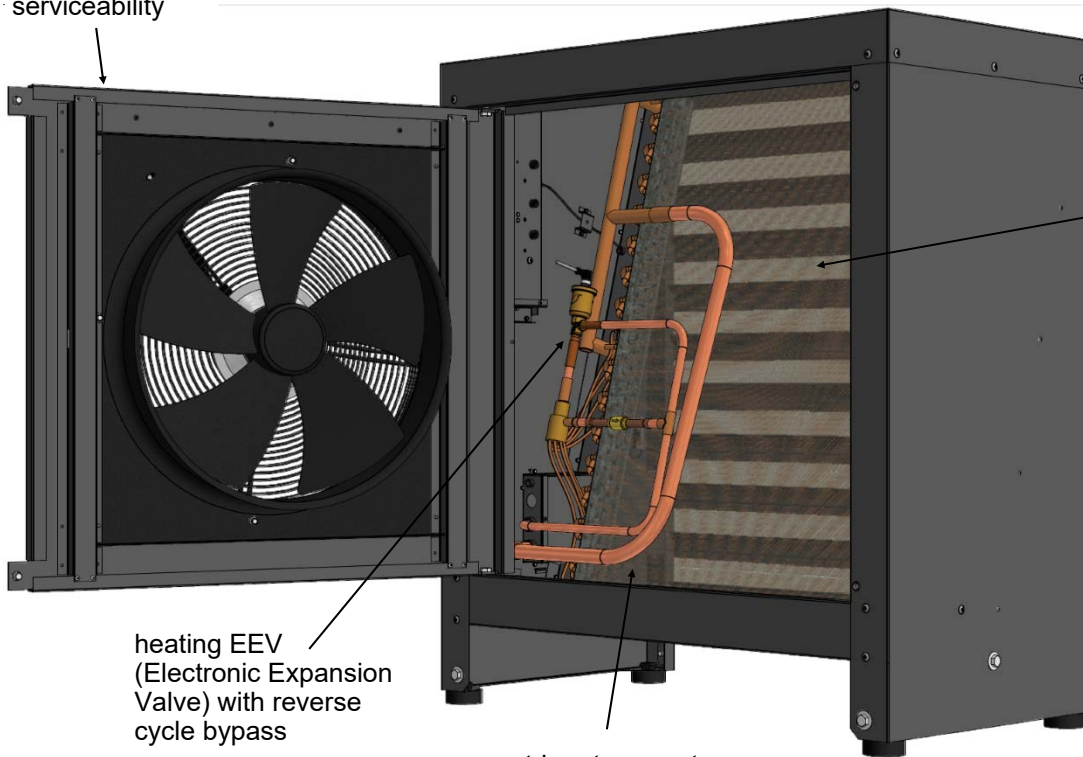

air coil with heavy duty fins, installed at slant for most effective condensate runoff and no drip tray where condensate could re-freeze

intelligent defrost logic eliminates unnecessary defrosts and ensures complete defrost each time

heating EEV (Electronic Expansion Valve) with reverse cycle bypass

outdoor temperature sensor reads out on indoor unit



Dimensions

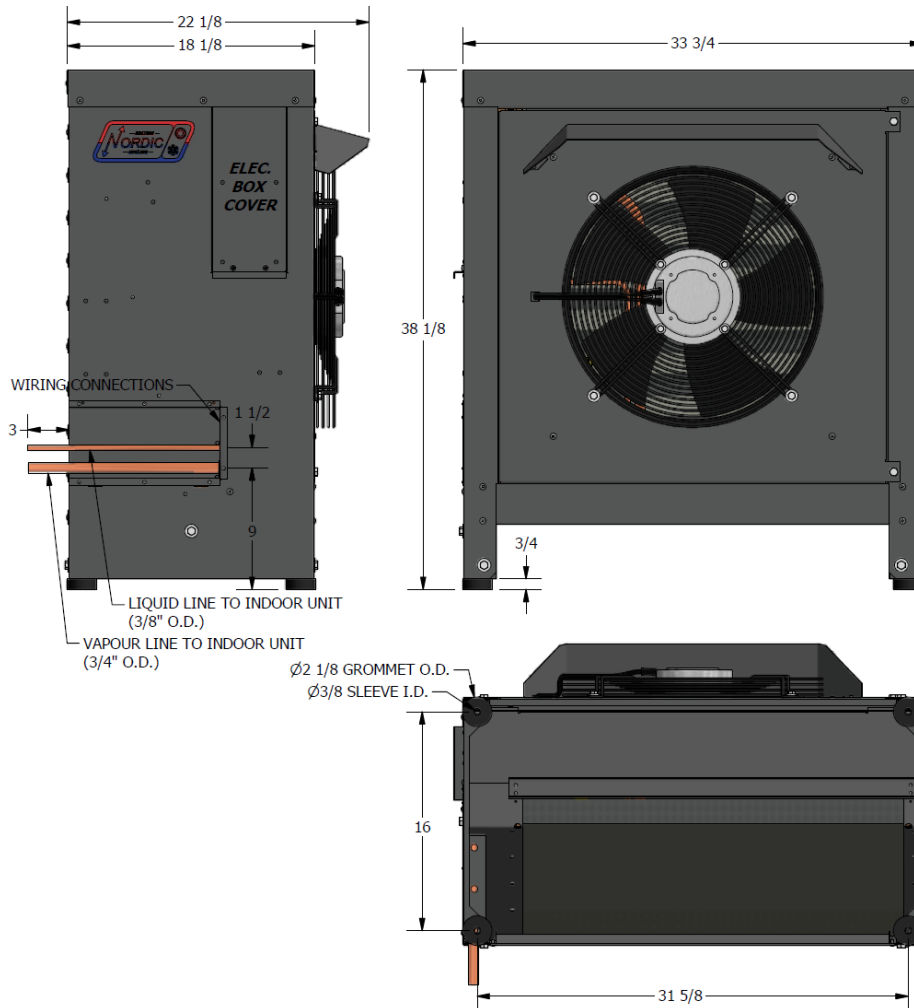
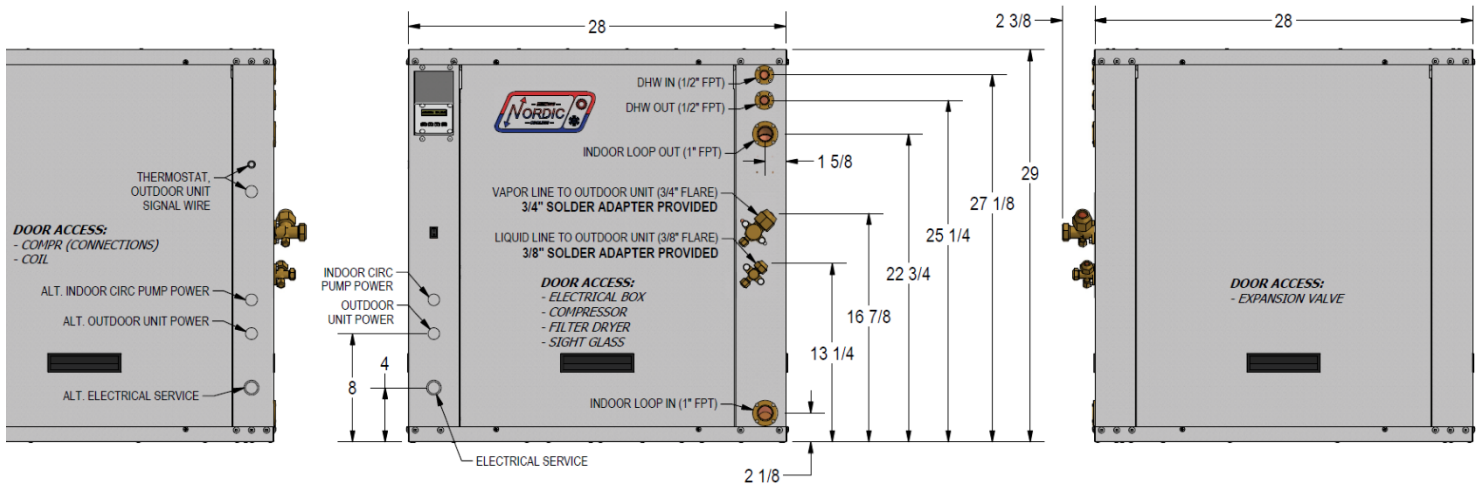

Dimensions

WITH LEG KIT

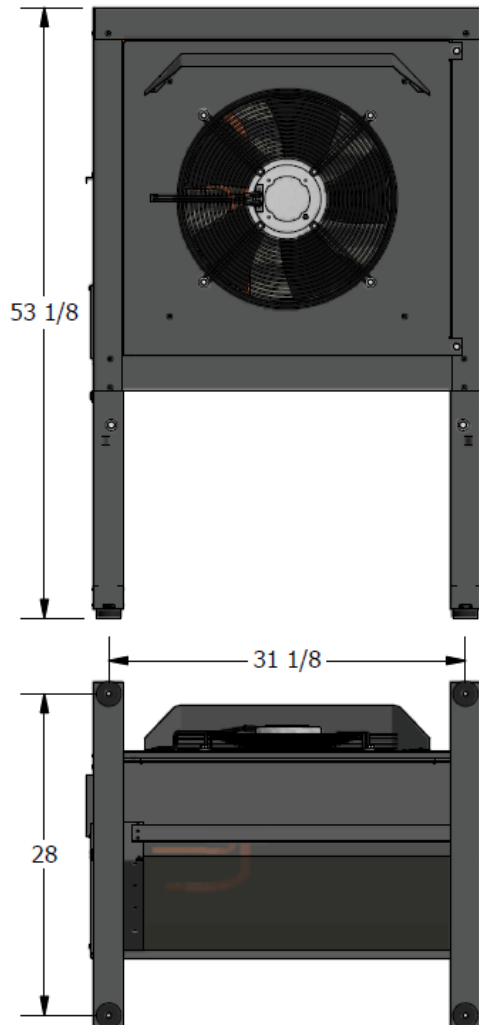

WITH TALL LEG KIT

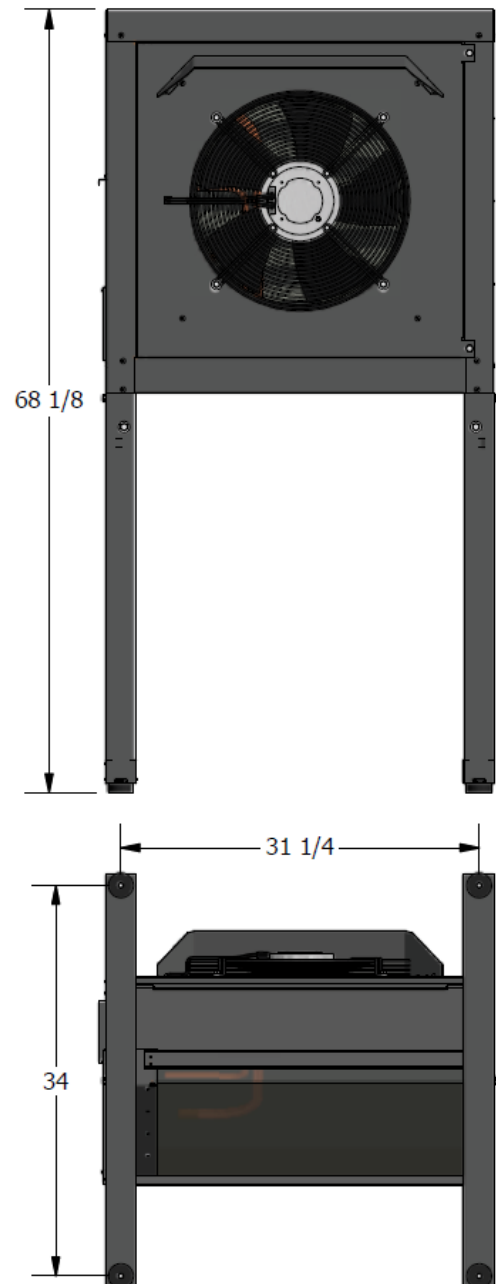

NOTE:

LEG KITS BOLT ON WITH SAME BOLTS AND WASHERS THAT HOLD FOOT PLATES ONTO ACE UNIT.

Specifications

Electrical Information											
Code	Power Supply			Compressor		Indoor Circulator	Outdoor Unit	FLA	MCA	Maximum Fuse/Breaker	Minimum Wire Size
	V- ϕ -Hz	MIN	MAX	RLA	LRA	Max A	Max A	Amps	Amps	Amps	ga
1	208/230-1-60	187	253	15.3	83	3.0	1.6	20.7	24.5	40	#8-2*
2	208-3-60	187	229	11.6	73	3.0	1.6	17.0	19.9	30	#10-3*
4	460-3-60	414	506	5.7	38	-	1.6	8.1	9.5	15	#14-3

*one additional conductor required if connecting 115VAC circulators to unit.

Shipping Information				
ITEM	WEIGHT lb. (kg)	DIMENSIONS in (cm)		
		L	W	H
ATW-45 Indoor Unit	294 (133)	34 (86)	34 (86)	35 (89)
ATW-45 Outdoor Unit	230 (104)	36 (91)	70 (178)	45 (114)

Refrigerant - R410a		
MODEL	lb.	kg
ATW-45	7.5	3.4

See unit nameplate for final charge.
System contains POE oil.

Flow & Pressure Drop	
gpm	ΔP (psi)
7.0	2.1
8.0	2.8
9.0	3.5
10.0	4.0
11.0	4.6
12.0	5.5
13.0	6.2

Indoor Unit Sound Levels (dBA)*		
MODEL	1 ft distance	3 ft distance
ATW-45	57.2	56.0

* With all doors installed.

Outdoor Unit Sound Levels (dBA)*								
MODEL	1 ft distance		3 ft distance		5 ft distance		10 ft distance	
	Front	Side	Front	Sides	Front	Sides	Front	Sides
ATW-45	68.0	61.1	66.4	59.7	63.5	57.4	59.3	56.7

* At maximum fan speed. This occurs in heating mode, or in cooling mode with outdoor greater than ~27°C.

Operating Temperature Limits					
Loop	Mode	Parameter	(°F)	(°C)	Note
Indoor	Heating	Minimum ELT	60	15	
	Heating	Maximum LLT	120	49	
	Cooling	Minimum LLT	41	5	Water system (no antifreeze).
	Cooling	Minimum LLT	32	0	Antifreeze system. Adequate freeze protection required.
	Cooling	Maximum ELT	80	27	
Outdoor	Heating	Minimum EAT	-7	-22	ACE Outdoor Unit automatically stops compressor below this temp.
	Cooling	Maximum EAT	120	49	ACE Outdoor Unit automatically stops compressor above this temp.

* Values in this table are for rated liquid flow values.

Standard Capacity Ratings - Heating														60 Hz			
Indoor Loop ELT 104°F (40°C)					H12 - Outdoor Air 47°F (8.3°C)				H22 - Outdoor Air 35°F (1.7°C)				H32 - Outdoor Air 17°F (-8.3°C)				
Model	Indoor Liquid Flow		Pressure Drop		Stage	Input Energy		Capacity		COP _H	Input Energy		Capacity		COP _H		
	gpm	L/s	psi	kPa		Watts	Btu/hr	kW	W/W		Watts	Btu/hr	kW	W/W			
45	10.0	0.63	3.8	26	2	2518	33,600	9.9	3.91	2581	29,200	8.6	3.32	2742	22,000	6.5	2.35

Standard Capacity Ratings - Cooling														60 Hz			
Indoor Loop ELT 53.6°F (12°C)					B2 - Outdoor Air 82°F (27.8°C)					A2 - Outdoor Air 95°F (35°C)							
Model	Indoor Liquid Flow		Pressure Drop		Stage	Input Energy		Capacity		EER	COP _c	Input Energy		Capacity		EER	COP _c
	gpm	L/s	psi	kPa		Watts	Btu/hr	kW	Btu/W-hr			W/W	Watts	Btu/hr	kW		
45	10.0	0.63	3.8	26	2	2247	29,300	8.6	13.0	3.82	2591	26,300	7.7	10.2	2.98		

Performance Tables

Heating Mode

ATW-45-HACW-P-1T					R410a 60 Hz						
Outdoor Unit			Electrical		Heating Data (Indoor Unit)						
Air Temp	Evaporating Temp	HAB	Compressor Current	Input Power	ELT	Condensing Temp	Liquid Flow	LLT	Delta T	Heating Capacity	COPh
°F	°F	Btu/hr	Amps	Watts	°F	°F	gpm	°F	°F	Btu/hr	W/W
°C	°C	Watts			°C	°C	L/s	°C	°C	Watts	
-5.0	-16.2	5,390	14.0	3,394	104	112	10.0	107.4	3.4	16,787	1.45
-20.6	-26.8	1,579			40.0	44.4	0.631	41.9	1.9	4,919	
5.0	-7.8	9,211	12.0	2,942	104	112.5	10.0	107.8	3.8	19,065	1.90
-15.0	-22.1	2,699			40.0	44.7	0.631	42.1	2.1	5,586	
19.5	5	12,856	11.1	2,742	104	113	10.0	108.4	4.4	22,026	2.35
-6.9	-15.0	3,767			40.0	45.0	0.631	42.4	2.4	6,454	
25.0	8.8	16,517	10.7	2,655	104	113.5	10.0	109.1	5.1	25,392	2.80
-3.9	-12.9	4,839			40.0	45.3	0.631	42.8	2.8	7,440	
35.0	17.2	20,597	10.4	2,581	104	114	10.0	109.8	5.8	29,218	3.32
1.7	-8.2	6,035			40.0	45.6	0.631	43.2	3.2	8,561	
45.0	25.7	25,228	10.1	2,518	104	114.5	10.0	110.7	6.7	33,634	3.91
7.2	-3.5	7,392			40.0	45.8	0.631	43.7	3.7	9,855	
55.0	34.2	27,481	9.8	2,450	104	115	10.0	111.1	7.1	35,655	4.26
12.8	1.2	8,052			40.0	46.1	0.631	44.0	4.0	10,447	
65.0	42.9	31,062	9.6	2,369	104	115.5	10.0	111.8	7.8	38,961	4.82
18.3	6.1	9,101			40.0	46.4	0.631	44.3	4.3	11,415	

Compressor: ZPS30K5E-PFV

Cooling Mode

ATW-45-HACW-P-1T					R410a 60 Hz						
Outdoor Unit			Electrical		Cooling Data (Indoor Loop)						
Air Temp	Condensing Temp	Rejection	Compressor Current	Input Power	ELT	Evaporating Temp	Liquid Flow	LLT	Delta T	Cooling Capacity	EER (COPc)
°F	°F	Btu/hr	Amps	Watts	°F	°F	gpm	°F	°F	Btu/hr	Btu/W-hr
°C	°C	Watts			°C	°C	L/s	°C	°C	Watts	W/W
50	62	5,390	5.2	1,489	53.6	38.8	10.0	46.3	7.3	36,226	24.3
10.0	16.7	1,579			12.0	3.8	0.631	8.0	4.0	10,614	7.13
60	72	9,211	6.2	1,742	53.6	39.0	10.0	46.8	6.8	34,145	19.6
15.6	22.2	2,699			12.0	3.9	0.631	8.2	3.8	10,004	5.74
70	83	12,856	7.2	1,989	53.6	39.2	10.0	47.2	6.4	31,898	16.0
21.1	28.3	3,767			12.0	4.0	0.631	8.5	3.5	9,346	4.70
80	93	16,517	8.2	2,201	53.6	39.4	10.0	47.7	5.9	29,621	13.5
26.7	33.9	4,839			12.0	4.1	0.631	8.7	3.3	8,679	3.94
90	104	20,597	9.5	2,458	53.6	39.6	10.0	48.2	5.4	27,226	11.1
32.2	40.0	6,035			12.0	4.2	0.631	9.0	3.0	7,977	3.25
100	114	25,228	10.7	2,724	53.6	39.8	10.0	48.6	5.0	24,911	9.1
37.8	45.6	7,392			12.0	4.3	0.631	9.2	2.8	7,299	2.68
110	125	27,481	12.4	3,070	53.6	40.0	10.0	49.1	4.5	22,465	7.3
43.3	51.7	8,052			12.0	4.4	0.631	9.5	2.5	6,582	2.14
120	135	31,062	14.2	3,443	53.6	40.2	10.0	49.6	4.0	19,992	5.8
48.9	57.2	9,101			12.0	4.6	0.631	9.8	2.2	5,858	1.70

Compressor: ZPS30K5E-PFV

Wiring Diagram (208/230-1-60)

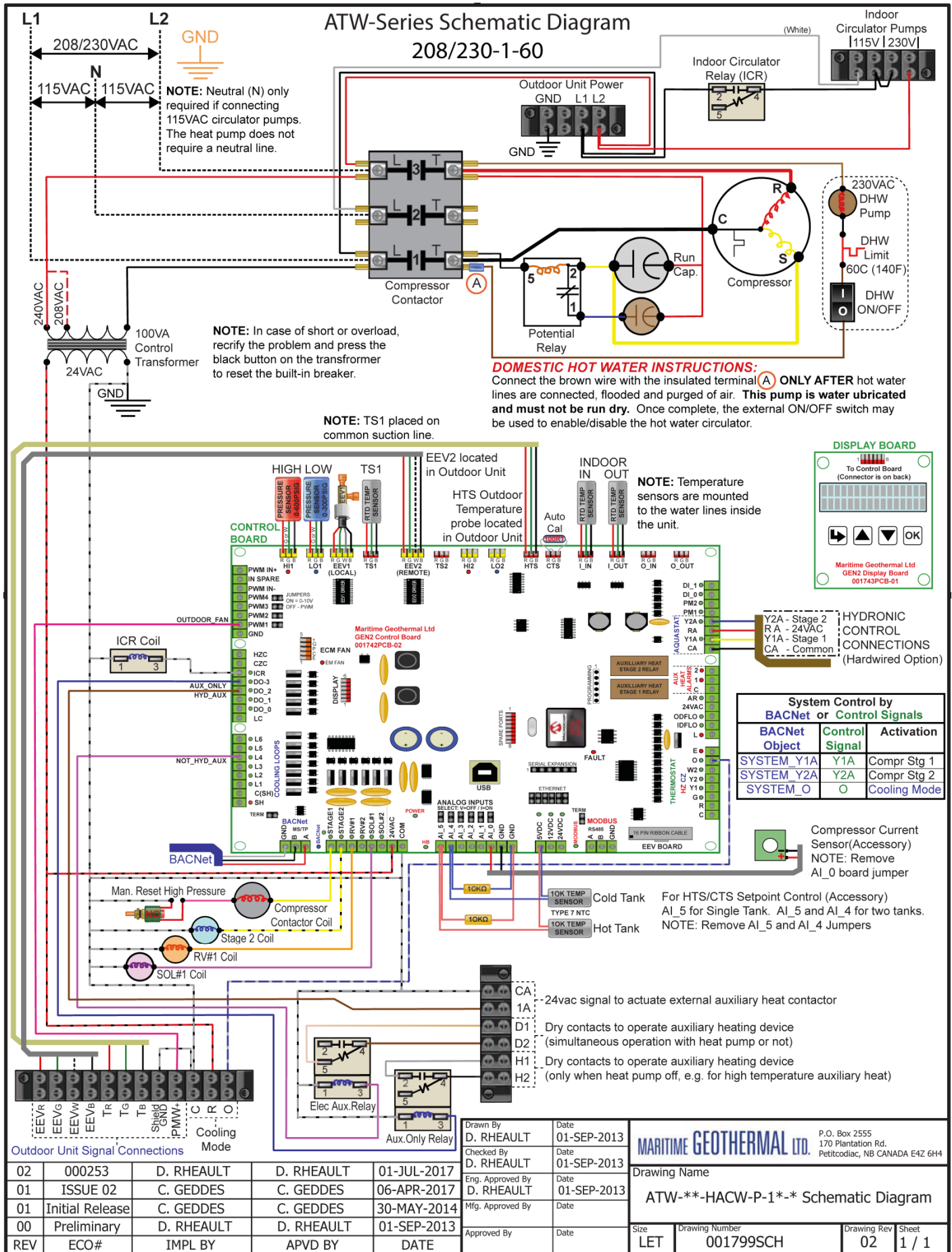

Drawn By D. RHEAULT	Date 01-SEP-2013	<p>P.O. Box 2555 170 Plantation Rd. Petitcodiac, NB CANADA E4Z 6H4</p>
Checked By D. RHEAULT	Date 01-SEP-2013	
Eng. Approved By D. RHEAULT	Date 01-SEP-2013	
Mfg. Approved By	Date	
Approved By	Date	
Drawing Name ATW-**-HACW-P-1** Schematic Diagram		Drawing Rev Sheet 02 1 / 1
Size LET	Drawing Number 001799SCH	

Electrical Box Layout (208-3-60)

ATW-Series Electrical Box Diagram 208-3-60

SYSTEM CONTROL DESCRIPTION

System Control by BACNet or External Control Signals		
BACNet Object	External	Activation
SYSTEM_Y1A	Y1A	Compressor Stage 1
SYSTEM_Y2A	Y2A	Compressor Stage 2
SYSTEM_O	O	Heating (OFF) / Cooling (ON)

BACNet INTERFACE CONNECTIONS (MS/TP RS-485)

Use twisted pair shielded, conductor cable to connect the BACNet connections to the control board connector.
 A - Communication (+)
 B - Communication (-)
 GND - Ground

EXTERNAL CONTROL CONNECTIONS (24VAC)

For cooling mode activation, use 18-2 wire to terminal strip to connect:
 R - 24VAC Hot
 O - Cooling Mode (Active) / Heating Mode (Inactive)

If using an aquastat ("Signals" control method), use these connections in addition:
 C - 24VAC Common (terminal strip)
 Y1A - Compressor Stage1 (right board connector)
 Y2A - Compressor Stage2 (right board connector)

A dry contact connection (Y1A, Y2A or O) will activate the external control signal input to the control board.

AUXILIARY HEAT CONTROL CONNECTIONS

Use an 18-2 conductor cable.
 Choose one of 3 types of auxiliary heat connections:

CA | 24VAC signal to operate external auxiliary heat
 1A | contactor (Max load 500mA.)

D1 | Dry contacts, closed when ATW calls for aux. heat
 D2 |

H1 | Dry contacts, closed when ATW calls for aux. heat
 H2 | (only when compressor OFF; use for high temperature backup heating devices)

OUTDOOR UNIT SIGNAL CONNECTIONS (24VAC)

Use an 18-8 shielded cable to connect the Outdoor Unit Signal Connections to the matching Outdoor Unit Signal Connections in the heat pump electrical box. Connect the shield ground to the Shield Ground terminal.

OUTDOOR UNIT POWER CONNECTIONS (208VAC)

Use a minimum of #14-2 outdoor rated cabling to connect the power supply of the outdoor unit to the matching terminals of the Outdoor Power Supply terminal strip in the electrical box of the heat pump.

CIRCULATOR CONNECTIONS (208~230/115VAC)

REFER TO LABEL IN UNIT FOR MAX LOAD (AMPS)
 Connect 115VAC circulators to 115V
 Connect 230VAC circulators to 230V

POWER SUPPLY CONNECTIONS

*NOTE: Neutral (N) is only required if connecting 115VAC circulators.
 The heat pump itself does not require a neutral.

208/115VAC CONNECTIONS		
Wire	Colour	Contactors (Label)
Neutral*	White	N*
Line 3	Red	L3
Line 2	Blue	L2
Line 1	Black	L1

Connect "GND" to Gnd.Lug

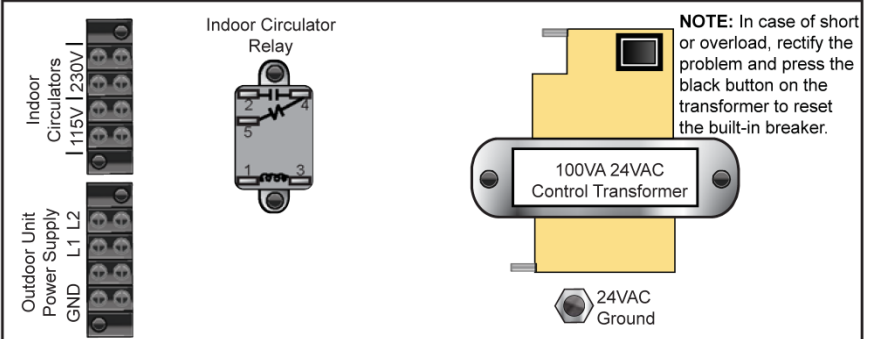
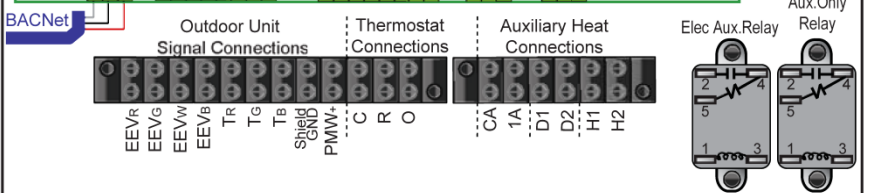
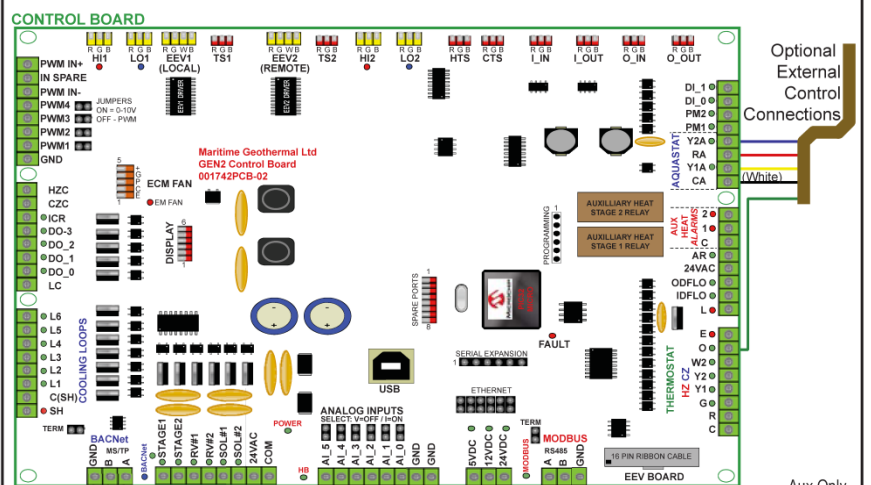

IMPORTANT NOTE FOR 3 PHASE POWER
 If on initial startup the compressor is noisy and not pumping, reverse L1 and L2 supply wires.

DOMESTIC HOT WATER INSTRUCTIONS:

Connect the brown wire with the insulated terminal **ONLY AFTER** hot water lines are connected, flooded and purged of air. **This pump is water lubricated and must not be run dry.** Once complete, the external ON/OFF switch may be used to enable/disable the hot water circulator.

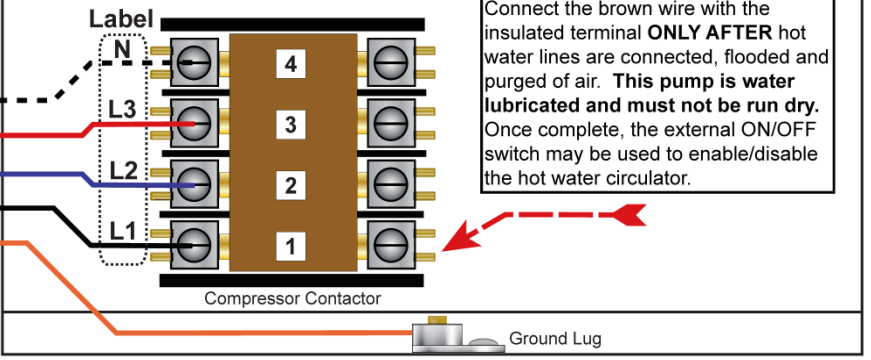

Drawn By D. RHEAULT	Date 01-NOV-2016	MARITIME GEOTHERMAL LTD.	P.O. Box 2555 170 Plantation Rd. Petitcodiac, NB CANADA E4Z 6H4
Checked By D. RHEAULT	Date 01-NOV-2016		
Eng. Approved By D. RHEAULT	Date 01-NOV-2016	Drawing Name ATW-**-HACW-P-2*-** Electrical Box Diagram	
Mfg. Approved By	Date	Size LET	Drawing Number 002189ELB
Approved By	Date	Drawing Rev 02	Sheet 1 / 1

Wiring Diagram (460-3-60)

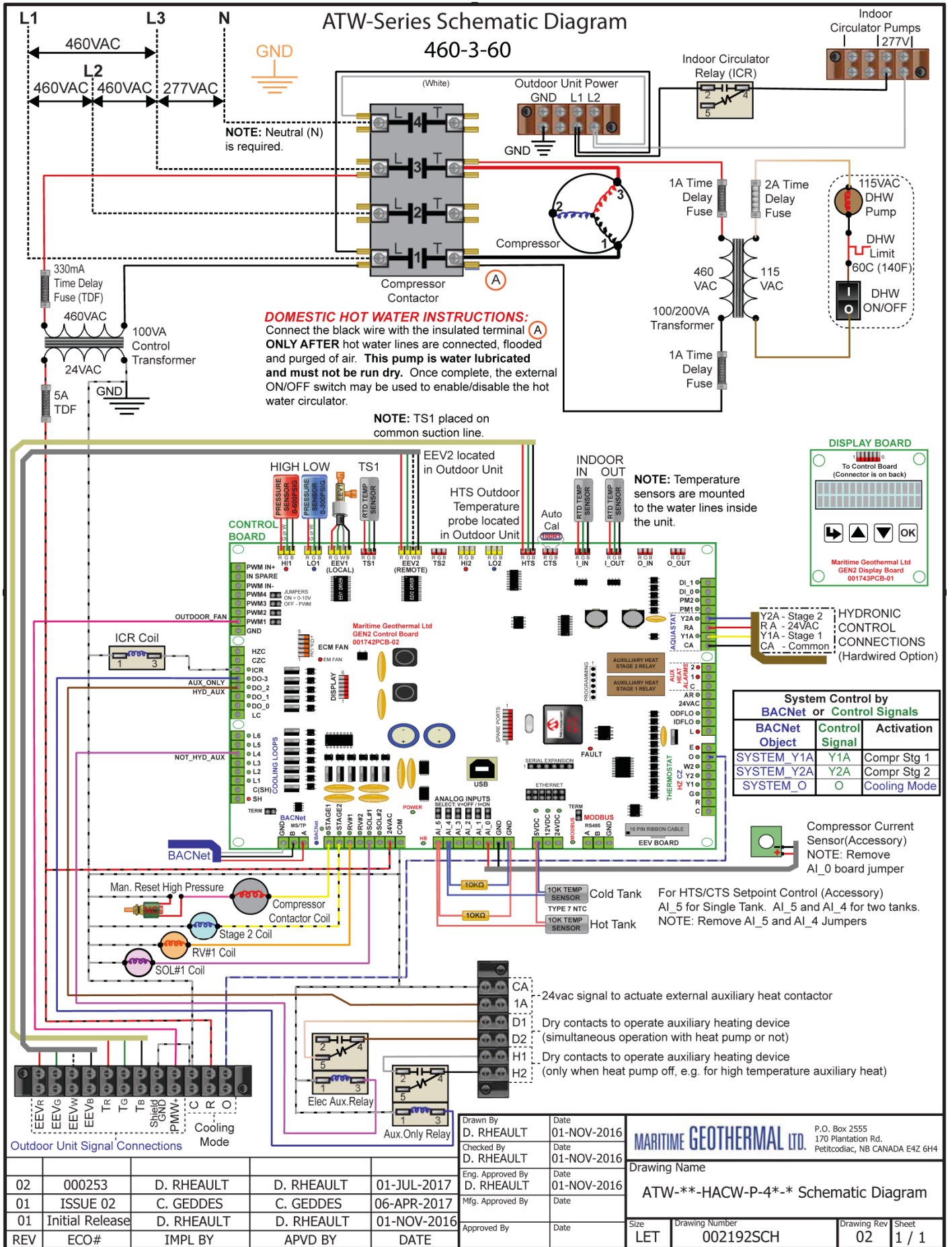

Electrical Box Layout (460-3-60)

ATW-Series Electrical Box Diagram 460-3-60

SYSTEM CONTROL DESCRIPTION

System Control by BACNet or External Control Signals		
BACNet Object	External	Activation
SYSTEM_Y1A	Y1A	Compressor Stage 1
SYSTEM_Y2A	Y2A	Compressor Stage 2
SYSTEM_O	O	Heating (OFF) / Cooling (ON)

BACNet INTERFACE CONNECTIONS (MS/TP RS-485)

Use twisted pair shielded, conductor cable to connect the BACNet connections to the control board connector.
 A - Communication (+)
 B - Communication (-)
 GND - Ground

EXTERNAL CONTROL CONNECTIONS (24VAC)

For cooling mode activation, use 18-2 wire to terminal strip to connect:
 R - 24VAC Hot
 O - Cooling Mode (Active) / Heating Mode (Inactive)

If using an external aquastat ("Signals" control method), use these connections in addition:
 C - 24VAC Common (terminal strip)
 Y1A - Compressor Stage1 (right board connector)
 Y2A - Compressor Stage2 (right board connector)

A dry contact connection between R and any external control connection (Y1A, Y2A or O) will activate the external control signal input to the control board.

AUXILIARY HEAT CONTROL CONNECTIONS

Use an 18-2 conductor cable.
 Choose one of 3 types of auxiliary heat connections:

CA : 24VAC signal to operate external auxiliary heat
 1A : contactor (Max load 500mA.)

D1 : Dry contacts, closed when ATW calls for aux. heat
 D2 : Dry contacts, closed when ATW calls for aux. heat

H1 : Dry contacts, closed when ATW calls for aux. heat
 H2 : (only when compressor OFF; use for high temperature backup heating devices)

OUTDOOR UNIT SIGNAL CONNECTIONS (24VAC)

Use an 18-8 shielded cable to connect the Outdoor Unit Signal Connections to the matching Outdoor Unit Signal Connections in the heat pump electrical box. Connect the shield ground to the Shield Ground terminal.

OUTDOOR UNIT POWER CONNECTIONS (277VAC)

Use a minimum of #14-2 outdoor rated cabling to connect the power supply of the outdoor unit to the matching terminals of the Outdoor Power Supply terminal strip in the electrical box of the heat pump.

CIRCULATOR CONNECTIONS (277VAC)

REFER TO LABEL IN UNIT FOR MAX LOAD (AMPS)
 Connect 277VAC circulators to 277V

POWER SUPPLY CONNECTIONS

*NOTE: Neutral (N) is required for heat pump operation.

460/277VAC CONNECTIONS		
Wire	Colour	Contactors (Label)
Neutral*	White	N*
Line 3	Red	L3
Line 2	Blue	L2
Line 1	Black	L1

Connect "GND" to Gnd.Lug

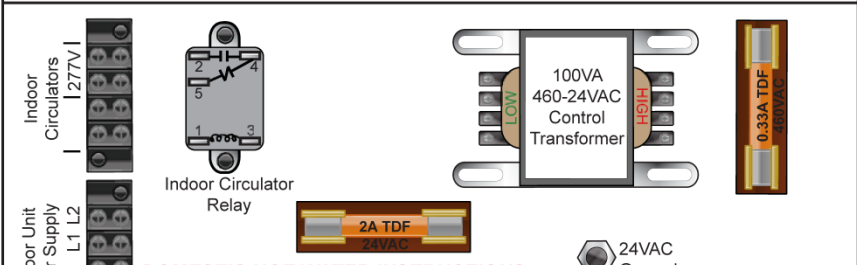
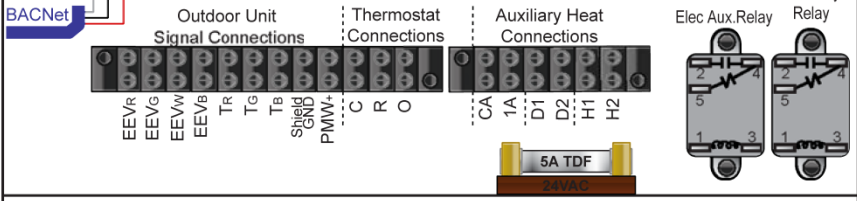
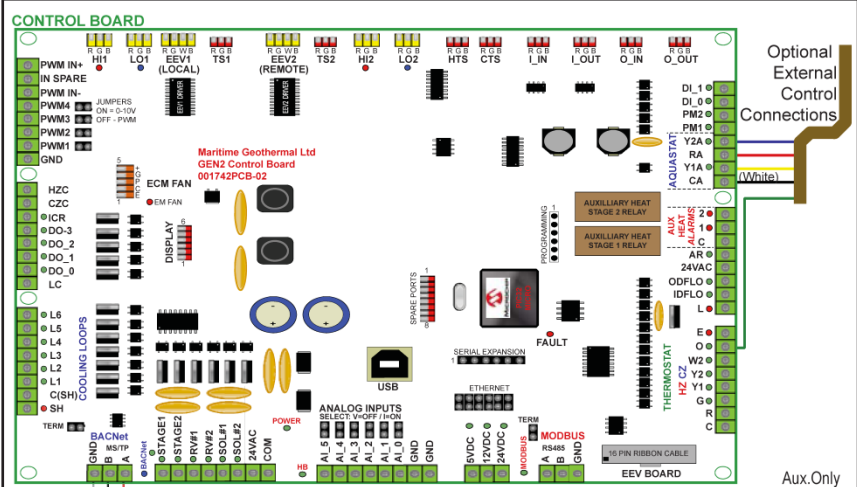

DOMESTIC HOT WATER INSTRUCTIONS:

Connect the black wire with the insulated terminal **ONLY AFTER** hot water lines are connected, flooded and purged of air. **This pump is water lubricated and must not be run dry.** Once complete, the external ON/OFF switch may be used to enable/disable the hot water circulator.

IMPORTANT NOTE FOR 3 PHASE POWER
 If on initial startup the compressor is noisy and not pumping, reverse L1 and L2 supply wires.

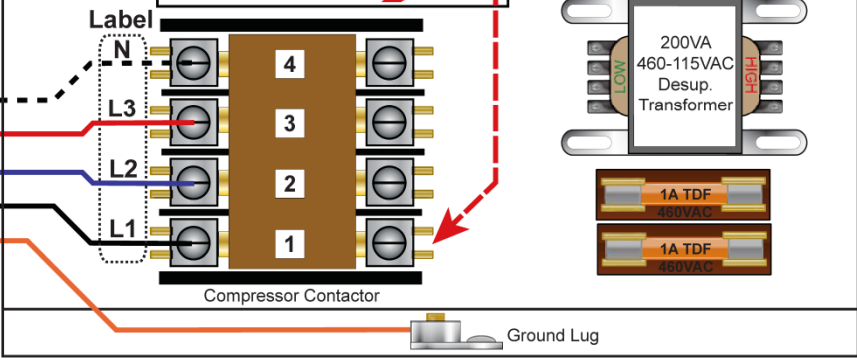

Drawn By D. RHEAULT	Date 01-NOV-2016		P.O. Box 2555 170 Plantation Rd. Petitcodiac, NB CANADA E4Z 6H4	
Checked By D. RHEAULT	Date 01-NOV-2016		Drawing Name	
Eng. Approved By D. RHEAULT	Date 01-NOV-2016		ATW-**-HACW-P-4*-* Electrical Box Diagram	
Mfg. Approved By	Date		Size LET	Drawing Number 002191ELB
Approved By	Date		Drawing Rev 02	Sheet 1 / 1

ATW Series Refrigeration Circuit Cooling / Defrost Mode

ITEM	STATUS
RV#1	ENERGIZED
SOL#1	ENERGIZED
EEV#1	ACTIVE
EEV#2	OPEN

ACE OUTDOOR UNIT

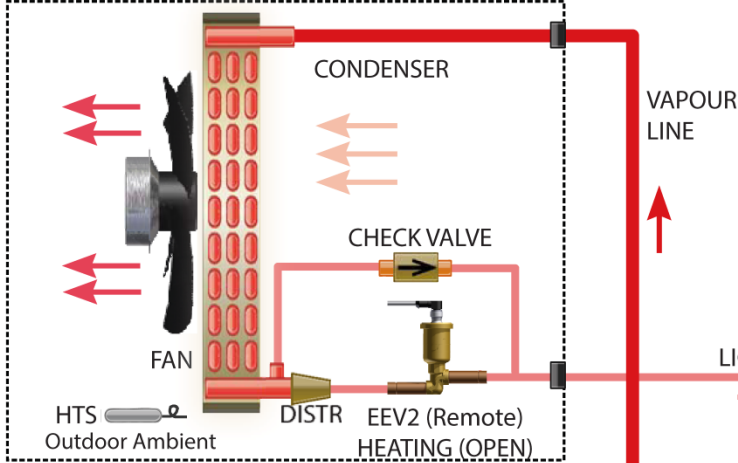

ATW INDOOR UNIT

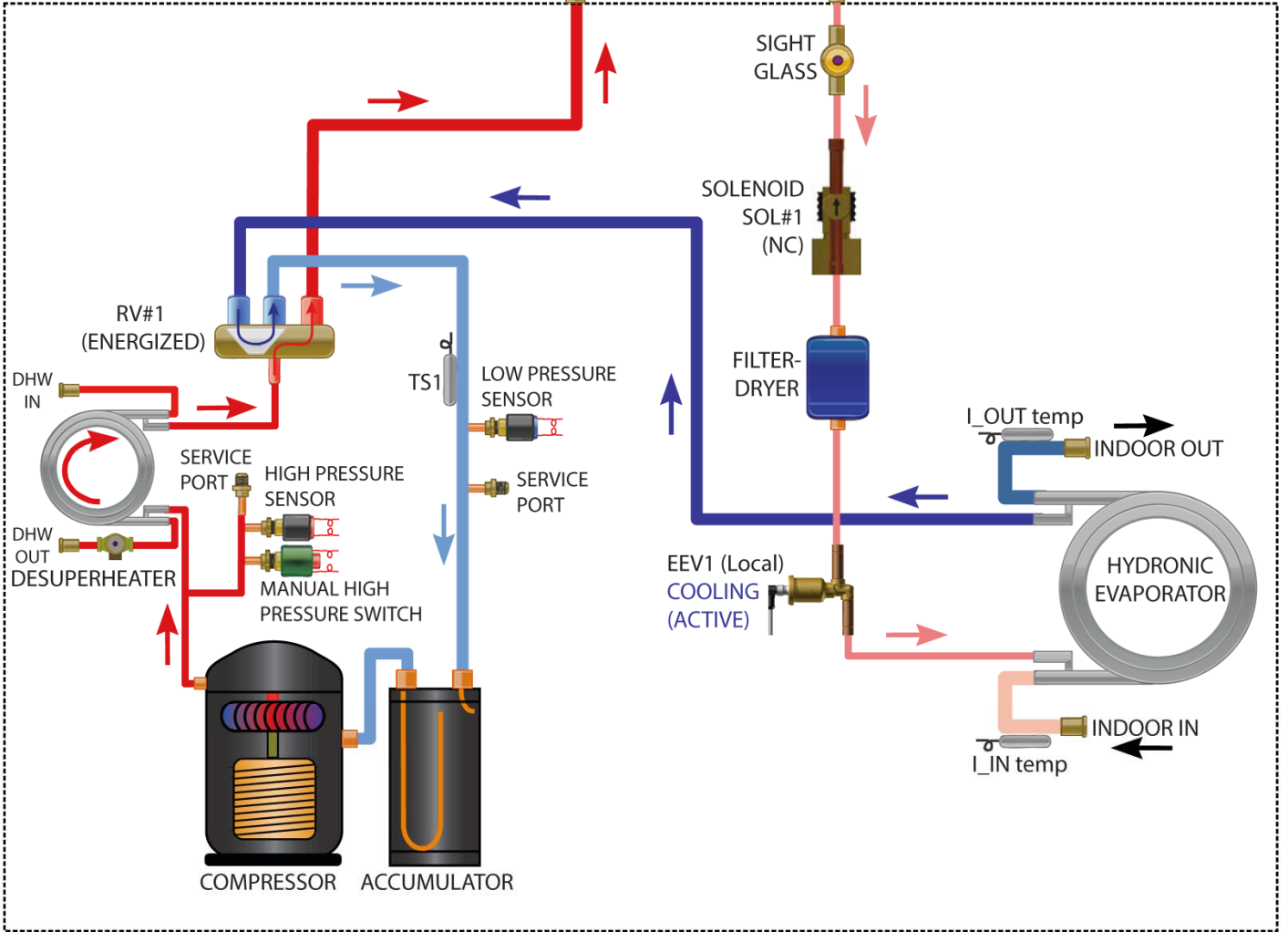

Drawn By C.GEDDES	Date 16-JUL-2014
Checked By C.GEDDES	Date 16-JUL-2014
Eng. Approved By C.GEDDES	Date 16-JUL-2014
Mfg. Approved By	Date
Approved By	Date

MARITIME GEOTHERMAL LTD.		P.O. Box 2555 170 Plantation Rd. Petitcodiac, NB CANADA E4Z 6H4	
Drawing Name ATW-Series Refrigeration Circuit Cooling / Defrost Mode			
Size LET	Drawing Number 001841RCD	Drawing Revision 02	Sheet 1 / 1

02	000253	D. RHEAULT	D. RHEAULT	01-JUL-2017
01	Initial Release	C. GEDDES	C. GEDDES	16-JUL-2014
REV	ECO#	IMPL BY	APVD BY	DATE

BACnet Interface

The BACnet interface is an MS/TP connection via RS-485 twisted pair. There is a termination jumper if required to terminate the connection. It is located just above the BACnet connector, marked as TERM on the control board.

The connector on the control board is a three wire removable screw connector. The signals are as follows:

- A: Communications line (+) (right pin)
- B: Communications line (-) (middle pin)
- C: Ground connection (left pin)

Vendor: Maritime Geothermal Ltd.

Vendor ID: 260

Model Name: MGT GEN2 Control Board

The following parameters can be set via the LED Display Configuration Menu or via the PC APP Configuration Page.

- 1) Baud rate
- 2) Instance number
- 3) MAC address

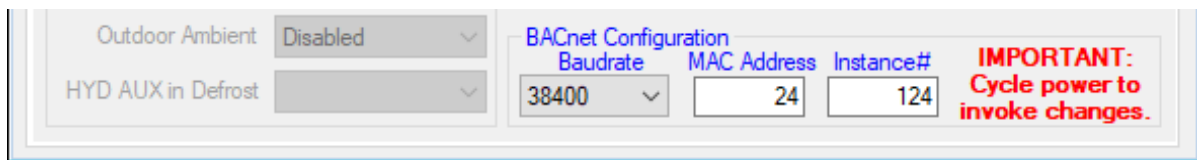

The data is available regardless of the selected control method. In order to control the unit via the BACnet interface, set the Control Source to BACnet either by using the PC APP configuration page or the display menus.

The following tables provide a list of the objects applicable to this model series, along with a description of each.

Note that there may be other objects available that do not apply to this model.

BACnet OBJECTS - CONTROL SIGNALS (READ/WRITE)				
Name	Data Type	ID	Property	Description
SYSTEM_Y1A	Binary Value	BV0	Present Value	Stage 1 (compressor) (active is on)
SYSTEM_Y2A	Binary Value	BV1	Present Value	Compressor stage 2 solenoid (active is on)
SYSTEM_O	Binary Value	BV2	Present Value	Switch to cooling mode (RV#1). Inactive= HEATING , Active= COOLING
BACnet_Units	Binary Value	BV9	Present Value	Select the units to use for the BACnet objects

Note: object names may be subject to change without prior notice.

BACnet OBJECTS - DATA (READ ONLY)

Name	Data Type	ID	Property	Units	Description
LPS1	Analog Input	AI6	Present Value	PSIG (kPa)	Low pressure value (suction pressure)
HPS1	Analog Input	AI7	Present Value	PSIG (kPa)	High pressure value (discharge pressure)
EVAP1	Analog Input	AI8	Present Value	degF (degC)	Evaporating Temperature
COND1	Analog Input	AI9	Setpoint Value	degF (degC)	Condensing Temperature
Suction_Line1	Analog Input	AI10	Present Value	degF (degC)	Suction line temperature
Superheat1	Analog Input	AI11	Setpoint Value	degF (degC)	Superheat
EEV1_POS	Analog Input	AI12	Present Value	%	EEV1 position (% open)
EEV2_POS	Analog Input	AI19	Present Value	%	EEV2 position (% open)
Outside_Temp	Analog Input	AI20	Present Value	degF (degC)	Outdoor Ambient temperature
I_IN	Analog Input	AI23	Present Value	degF (degC)	Indoor IN temperature
I_OUT	Analog Input	AI24	Present Value	degF (degC)	Indoor OUT temperature
Comp1_Current	Analog Input	AI0	Present Value	A	compressor current draw (ACCESSORY)
AI_2	Analog Input	AI2	Present Value	User Selectable	User defined (0-5VDC or 4-20mA)
AI_3	Analog Input	AI3	Present Value	User Selectable	User defined (0-5VDC or 4-20mA)
AI_4	Analog Input	AI4	Present Value	User Selectable	User defined (0-5VDC or 4-20mA)
AI_5	Analog Input	AI5	Present Value	User Selectable	User defined (0-5VDC or 4-20mA)
PWM_IN	Analog Value	AV0	Present Value	%	PWM input (from external source)
PWM1	Analog Value	AV1	Present Value	%	PWM output value (spare)
PWM2	Analog Value	AV2	Present Value	%	PWM output value (spare)
PWM4	Analog Value	AV4	Present Value	%	IV2 - PWM or 0-10VDC for Indoor Loop water valve
STAGE1	Binary Output	BO0	Present Value	N/A	Compressor contactor (stage 1)
STAGE2	Binary Output	BO1	Present Value	N/A	Compressor stage 2 solenoid
ICR	Binary Output	BO2	Present Value	N/A	Indoor circulator control
DO_1	Binary Output	BO4	Present Value	N/A	IV1 (for 24VAC Indoor Loop water valve)
DO_2	Binary Output	BO5	Present Value	N/A	Hydronic Auxiliary
DO_3	Binary Output	BO6	Present Value	N/A	Hydronic Auxiliary Only (without compressor)
PHS_1	Binary Output	BO7	Present Value	N/A	Dry contact lockout pin for Stage 1
PHS_2	Binary Output	BO8	Present Value	N/A	Dry contact lockout pin for Stage 2
Indoor_Flow	Binary Value	BV11	Present Value	N/A	Indoor Loop flow switch (ACCESSORY)
Phase_Monitor1	Binary Value	BV12	Present Value	N/A	Phase Monitor (ACCESSORY)

Note: available objects may be subject to change without prior notice.

BACnet OBJECTS - ALARMS AND FAULTS (READ ONLY)

Name	Data Type	ID	Alarm / Fault	Description
LPS1	Analog Value	AI6	Alarm	Low pressure alarm
HPS1	Analog Value	AI7	Alarm	High pressure alarm
Indoor_Flow	Binary Value	BV11	Alarm	Indoor Loop flow alarm
Phase_Monitor1	Binary Value	BV12	Alarm	Phase Monitor alarm
PERM_ALARMS1	Binary Value	BV16	Alarm	Indicates a permanent alarm
LPS1	Analog Value	AI6	Fault	Low pressure sensor faulty or disconnected
HPS1	Analog Value	AI7	Fault	High pressure sensor faulty or disconnected
Suction_Line1	Analog Value	AI10	Fault	Suction line 1 temperature sensor faulty or disconnected.
Outside_Temp	Analog Value	AI20	Fault	Outside temperature sensor faulty or disconnected.
I_IN	Analog Value	AI23	Fault	Indoor IN temperature sensor faulty or disconnected.
I_OUT	Analog Value	AI24	Fault	Indoor OUT temperature sensor faulty or disconnected.

Note: objects may be subject to change without prior notice.

Engineering Guide Specifications

General

The air source hydronic heat pump shall consist of an indoor unit, containing the compressor and all electronics, and an outdoor unit containing only an air coil, fan, and expansion valve. The unit shall be capable of heating or cooling the indoor hydronic loop, for space heating or air conditioning purposes. The unit shall be listed by a nationally recognized safety-testing laboratory (NRTL), such as ETL, TUV, UL or CSA. The unit shall be rated in accordance with applicable standards of the Air Conditioning, Heating, and Refrigeration Institute / International Standards Organization (AHRI/ISO) and/or Canadian Standards Association (CSA). The heat pump, as manufactured by Maritime Geothermal, Petitcodiac, New Brunswick, shall be designed to operate correctly within the air and liquid temperature ranges specified on the "Minimum and Maximum Operating Temperatures" page of this engineering specification document.

Factory Quality

Each unit shall be run tested at the factory with water circulating in indoor loop and outdoor unit connected. Quality control system checks shall include: computerized nitrogen pressurized leak test, evacuation of refrigeration circuit to sustained vacuum, accurate system charge, detailed heating and cooling mode tests, and quality cross check all operational and test conditions to pass/fail criteria. Units tested without water flow are not acceptable. The units shall be warranted by the manufacturer against defects in materials and workmanship in accordance with the warranty section at the end of this document. Optional extended factory warranty coverage may be available.

Cabinet

Each unit shall be enclosed in a sheet metal cabinet. Cabinet shall be constructed of powder coated galvanized sheet metal of minimum 20 gauge. Sheet metal gauge shall be higher where structurally required. Design and construction of cabinet shall be such that it is rigid and passes the CSA/UL Loading Test requirements (200 lb roof test). All panels shall be lined with minimum 1/2 inch [12.7 mm] thick acoustic type glass fiber insulation. All insulation shall meet the fire retardant provisions of NFPA 90A. This material shall also provide acoustical benefit. The indoor unit must have a minimum of four access panels for serviceability of the compressor compartment. Units having only one access panel to compressor/heat exchangers/expansion device/refrigerant piping shall not be acceptable. The electrical box shall have separate holes and knockouts for entrance of line voltage and low voltage control wiring. All factory-installed wiring passing through factory knockouts and openings shall be protected from sheet metal edges at openings by plastic grommets.

Refrigerant Circuit

All units shall contain only one refrigerant circuit, containing a hermetic motor scroll compressor, Electronic Expansion Valves (EEVs), coaxial heat exchanger, factory installed high and low pressure sensors, manual reset high pressure switch, service ports, liquid line filter-dryer, sight glass, and suction accumulator.

Compressors shall be specified for heat pump duty with internal isolation consisting of rubber vibration isolators and mounting plate with rubber vibration isolators. Compressor motors shall have internal high temperature overload protection.

The water to refrigerant heat exchanger shall consist of a steel outer jacket with twisted copper inner tube, designed and certified for 600 psig [4136 kPa] working pressure on the refrigerant side and 450 psig [3108 kPa] on the water side. Heat exchangers headered together in parallel shall use a reverse-return or symmetrical arrangement on the water side and symmetrical arrangement on the refrigerant side to ensure even flow splitting. Heat exchangers shall be insulated over all of their outside surface with minimum 3/8" thick closed cell insulation. Insulation consisting of 1/8" closed-cell insulating tape shall not be acceptable.

The electronic expansion valves shall be of stepper-motor rather than pulsing type, and shall provide proper superheat control over the unit's operating range with minimal deviation from superheat setpoint. Superheat shall be determined through the suction pressure-temperature method. Externally mounted pressure controlled water regulating flow valves or thermostatic expansion valves (TXV's) in place of electronic expansion valves are not acceptable.

The suction accumulator shall be insulated with minimum 3/8" thick closed cell insulation to prevent condensation. The accumulator's internal oil return port shall be sized properly for the unit's operating range. To ensure proper oil return, suction accumulator shall not be 'oversized'.

Piping and Connections

The indoor unit shall have one set of primary water in and water out connections. The primary connection type shall be 1" nominal female National Pipe Thread (NPT). All water connectors shall be rigidly mounted to cabinet with corrosion resistant fasteners to prevent relative movement. All water connectors shall be constructed of copper or brass material for corrosion resistance.

All internal water and refrigerant piping shall be insulated with minimum 3/8" thick closed cell insulation. Insulation consisting of 1/8" closed-cell insulating tape shall not be acceptable.

The indoor unit shall be provided charged with sufficient refrigerant for the installed system to operate properly with up to 20 ft of interconnecting lineset. The indoor unit shall be equipped with two 3-way refrigerant access valves for connection to the outdoor unit, so that refrigerant does not need to be removed from the system during installation.

Electrical

Controls and safety devices shall be factory wired and mounted within the unit. Controls shall include 24 volt alternating current (24VAC) activated compressor contactor, and 24VAC 100VA transformer with built in circuit breaker or fused on both primary and secondary sides. A terminal strip with screw in terminals shall be provided for field control wiring. Units shall be name-plated for use with time delay fuses or circuit breakers. Unit controls shall be 24VAC and provide heating as required by the remote thermostat or controller, or on-board controller. Unit shall provide remote fault indication to the control system via serial communications as well as provide fault messages on the front panel LCD display.

Unit Control

The control system shall have the following features:

1. Anti-short cycle time delay on compressor operation. Time delay shall be a minimum of 5 minutes, for both thermostat demand and safety control reset starts. An override shall be provided to disable this delay for unit commissioning and testing purposes.
2. Random compressor start delay of 0-120 seconds on unit power up to facilitate starting multiple units after a power failure.
3. Compressor shutdown for high or low refrigerant pressures, Loss of Charge (LOC), optional low flow conditions, and for optional phase protection faults on three phase models.
4. Automatic intelligent reset: after a trip, unit shall automatically restart when short cycle delay expires if the fault has cleared. Should a fault reoccur 2 times sequentially then permanent lockout shall occur, requiring cycling of the power to the unit in order to reset.
5. Manual reset high pressure in case of electronic board failure.
6. The low pressure shall not be monitored for the first 90 seconds after a compressor start to prevent nuisance safety trips.
7. 2 x 16 backlit Liquid Crystal Display (LCD) and four buttons provide basic configuration and data access. Unit may be configured for stand alone operation.
8. Universal Serial Bus (USB) port for full data access and diagnostic information, including manual override of all inputs and outputs, data-logging and real-time charting.

Maritime Geothermal works continually to improve its products. As a result, the design and specifications of any product may be changed without notice. Please contact Maritime Geothermal at 1-506-756-8135 or visit www.nordicghp.com for latest design and specifications. Purchaser's approval of this data set signifies that the equipment is acceptable under the provisions of the job specification. Statements and other information contained herein are not express warranties and do not form the basis of any commercial contract or other agreement between any parties, but are merely Maritime Geothermal's statement of opinion regarding its products.

LIMITED RESIDENTIAL WARRANTY

MARITIME GEOTHERMAL LTD. warrants that the heat pumps manufactured by it shall be free from defects in materials and workmanship for a period of (5) FIVE YEARS after the date of installation or for a period of (5) FIVE YEARS AND (60) SIXTY DAYS after the date of shipment, whichever occurs first. In addition MARITIME GEOTHERMAL LTD. warrants that the compressor shall be free of defects in materials and workmanship for an additional period of (2) TWO YEARS from said date.

MARITIME GEOTHERMAL LTD. shall, at its option repair or replace any part or parts covered by this warranty which shall be returned to MARITIME GEOTHERMAL LTD., transportation charges prepaid, which, upon examination proves to be defective in materials or workmanship. Replacement or repaired parts and components are warranted only for the remaining portion of the original warranty period.

This warranty is subject to the following conditions:

1. The NORDIC® heat pump must be properly installed and maintained in accordance with MARITIME GEOTHERMAL LTD.'s installation and maintenance instructions.
2. The installer must complete the “**Installation Data Sheet**”, have it endorsed by the owner and return it to Maritime Geothermal Ltd. within 21 days of installation of the unit.
3. It is the responsibility of the building or general contractor to supply temporary heat to the structure prior to occupancy. These heat pumps are designed to provide heat only to the completely finished and insulated structure. Start-up of the unit shall not be scheduled prior to completion of construction and final duct installation for validation of this warranty.
4. It is the customer's responsibility to supply the proper quantity and quality of water.

If the heat pump, manufactured by MARITIME GEOTHERMAL LTD., fails to conform to this warranty, MARITIME GEOTHERMAL LTD.'s sole and exclusive liability shall be, at its option, to repair or replace any part or component which is returned by the customer during the applicable warranty period set forth above, provided that (1) MARITIME GEOTHERMAL LTD. is promptly notified in writing upon discovery by the customer that such part or component fails to conform to this warranty. (2) The customer returns such part or component to MARITIME GEOTHERMAL LTD., transportation charges prepaid, within (30) thirty days of failure, and (3) MARITIME GEOTHERMAL LTD.'s examination of such component shall disclose to its satisfaction that such part or component fails to meet this warranty and the alleged defects were not caused by accident, misuse, neglect, alteration, improper installation, repair or improper testing.