

SLAB ROLLER MODEL: SR-30 (30")

OPERATION MANUAL & PARTS LIST

SHIMPO *All for dreams*

NIDEC-SHIMPO AMERICA CORPORATION • Itasca, IL 60143 USA • Phone: (800) 237-7079 • (630) 924-7138 • Fax: (630) 924-0340
www.shimpoceramics.com • info@shimpoceramics.com

FORWARD (IMPORTANT)

USERS ARE REQUESTED TO READ CLOSELY THE CONTENTS OF THIS OPERATION MANUAL BEFORE OPERATION IN ORDER TO MAINTAIN THE MACHINE IN GOOD CONDITION AT ALL TIMES AND TO AVOID POSSIBLE DANGER BECASUE OF NEGLIGENCE.

PRELIMINARY NOTE:

- THE SR-30 PACKAGE CONTAINS TOTAL FOUR CARTONS.
 1. CARTON 4-1: TABLE FRAME
 2. CARTON 4-2: SLAB ROLLING UNIT, LEVELING HANDLE & CANVAS
 3. CARTON 4-3: TABLETOP
 4. CARTON 4-4: WAGON WHEEL AND CRANK HANDLE

HOW TO ASSEMBLE:

STEP 1:

FIRSTLY, OPEN CARTON 4-1

THIS CARTON SHOULD CONTAINS FOLLOWING PARTS:

1. FOUR LEGS
2. TWO SIDE RAILS WITH LATCHES
3. TWO END RAILS
4. TWO SLAB ROLLER MOUNTING BRACKETS
5. HARDWARE PACKAGE

STEP 2:

1. ASSEMBLE THE 4 LEGS TO SIDE/END RAILS WITH M10 X 20 CAP SCREW AND HEX NUT M10.

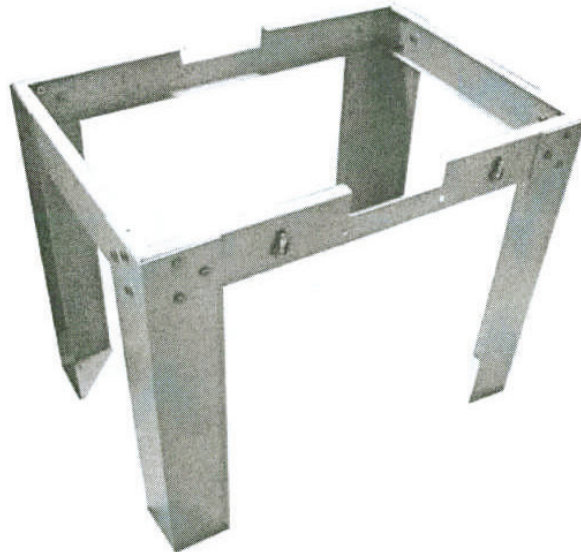

2. MOUNTING SLAB ROLLER'S BRACKET ONTO SIDE RAILS BY USING THE M10X 20 CAP SCREW AND WING NUT M10.

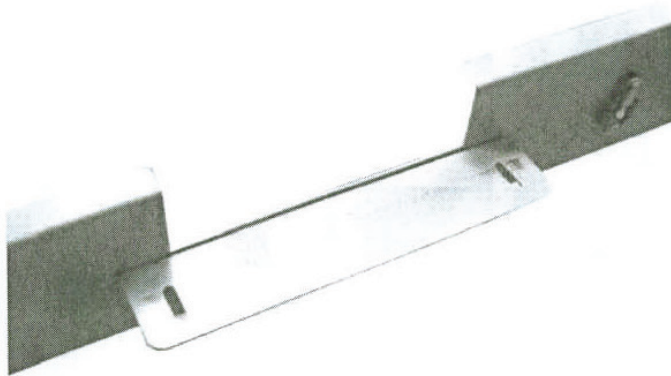

STEP 3: MOUNTING SLAB ROLLING UNIT ON THE FRAME

1. OPEN CARTON 4-2 SLAB ROLLER, THERE ARE 2 LEVELING HANDLE WHICH USED FOR THE THICKNESS ADJUSTMENT. SCREW THE LEVELING HANDLES ONTO THE WHEEL OF THE SLAB ROLLING UNIT

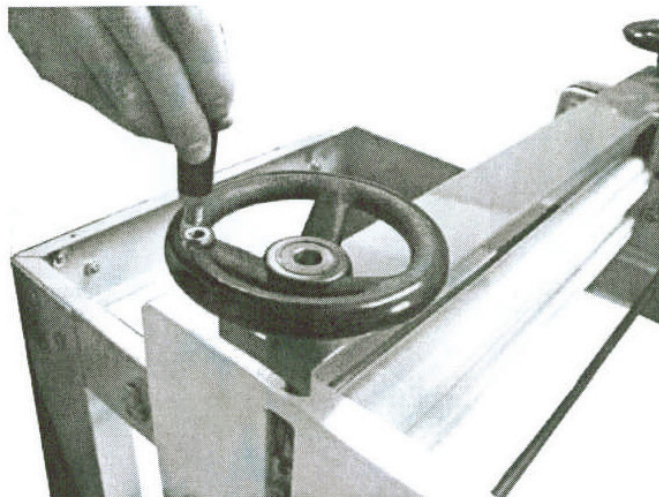

2. PUT THE SLAB ROLLING UNIT ONTO THE FRAME AND SCREWED BY USING THE M6 X 20 SOCKET CAP SCREW AND WING NUT M6.

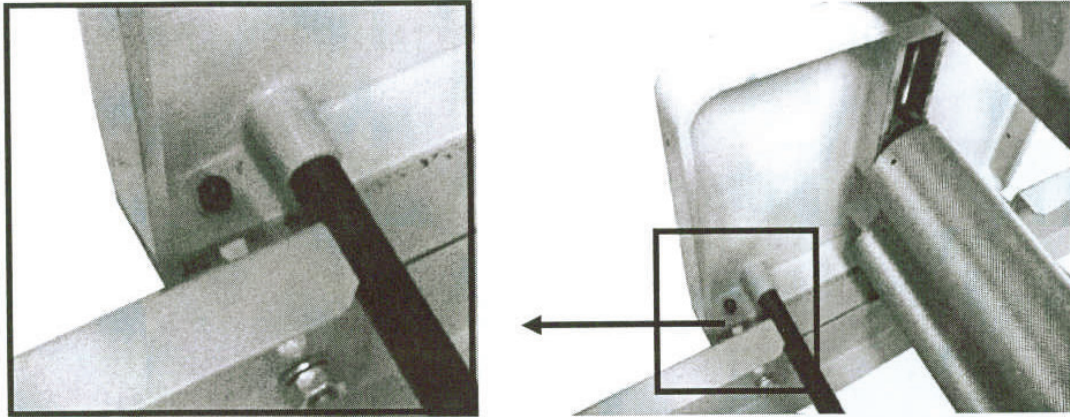

STEP 4: FASTEN THE CLASP BRACKET TO TABLETOP

1. OPEN CARTON 4-3 WHICH CONTENTS THE TABLETOP
2. BY USING THE M5 X 30 FLAT HEAD SOCKET CAP SCREW & WING NUT M5 FASTEN THE CLASP BRACKETS UNDER THE TABLETOP. BE SURE THE LIPS TO BE ABLE TO CLIP BY THE LATCHES.

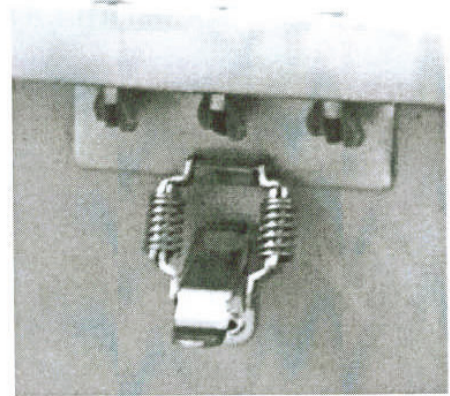
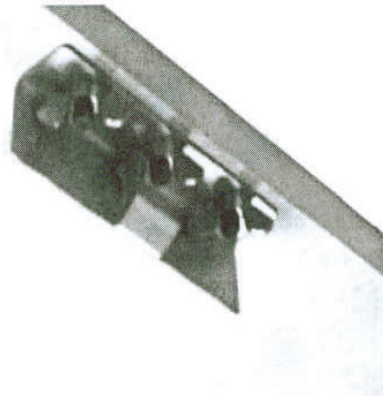

STEP 5: PUT THE WAGON WHEEL OR CRANK HANDLE WITH SLAB ROOLER

1. OPEN CARTON 4-4
2. DECIDE TO USE EITHER WAGON WHEEL OR CRANK HANDLE
3. LOOSEN THE SET SCREW ON THE WAGON WHEEL (OR CRANK HANDLE) AND PUT ON THE SHAFT. TURN SET SCREW TIGHTLY.

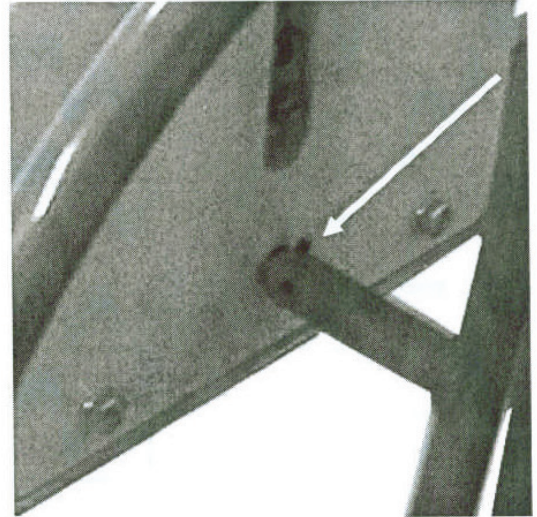
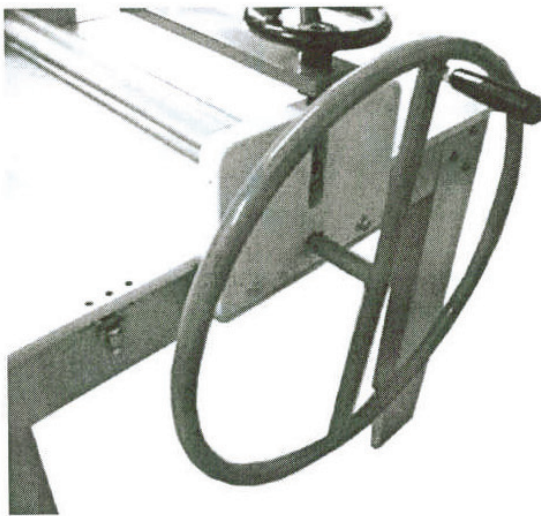











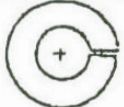

HOW TO OPERATE:

FOLLOWING STEPS ARE FOR YOU TO START ROLLING SLAB.

- 1) RAISING THE UPPER ROLL HIGHT BY USING THE LEVELING HANDLE ON THE ROLLING UNIT.
- 2) TAKE OUT THE CANVAS OUT OF THE CARTON 4-2. LAY OUT THE CANVAS TO ONE SIDE OF THE TABLETOP.
- 3) PUT SLICE CLAY ON CANVAS, MAY PRESS CLAY BY PALM FOR SOME THICKNESS.
- 4) COVER THE OTHER PIECE OF THE CANVAS. PUSH THE CANVAS EDGE INTO THE ROLLS. ADJUST THE THICKNESS BY HANDLE. THEN TURN THE WAGON WHEEL OR CRANK HANDLE FOR SLAB ROLLING.

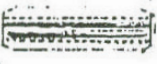
Hardware List

TOP VIEW	SIDE VIEW	DESCRIPTION	Q'TY	USED
		M10 x 20 cap screw	28	with following nuts to fasten legs and side/end rail together and to fasten Slab rolling unit mounting brackets to side rails
		M10 hex nut for above screw	28	with above
		M10 lock washer for above screw	28	with above
		M6 x 20 socket cap screw	4	with following 3 items to fasten the slab rolling unit to the mount- ing brackets after the frame is assembled
		M6 lockwasher	4	with screw above
		M6 wing nut	4	with screw above
		M3/M4/M5 short arm hex key	1	with screws, nuts and washer above
		clasp bracket	4	mounted to bottom of tabletop with the following screws, washer and nuts
		M5 x 30 flat head socket cap screw	12	to mount clasp bracket
		M5 lock washer	12	to mount clasp bracket
		M5 wing nut	12	to mount clasp bracket
		M5 x 25 spring pin	3	Spares
		M5 x 20 screw	4	to mount gear box cover
		1/4" x 3/4" wood screw	4	to mount tabletop with side/end rails after take the rolling unit out becomes a work table

Frame Assembly & Table Top

Parts No.	Description	Parts No.	Description
001	Table Leg		
001N	Hex Nut		
001P	Lock Washer		
001S	Hex Head Screw		
002	Side Rail		
002A	Latch		
002R	Rivet		
003	End Rail		
004	Mounting Bracket		
004N	Wing Nut		
004S	Hex Head Screw		
005	Table Top		
005N	Wing Nut		
005S	Flat Head Screw		
007	Wagon Wheel Handle		
007S	Socket Head Set Screw		
010	Clasp Bracket		
050	Grasp Handle		
050M	Nylon Washer		
050N	Hex Nut		
051	Crank Handle		

Slab Roller

Parts No.	Description	Parts No.	Description
006	Gear Guard	030U	Top Roller
006S	Round Head Screw	038	Nylon Washer
006W	Washer	039	Nylon Washer
007P	Pin	060	Drive/Driven Gear(same)
011	Indication Label	061	Small Idler Gear
013	Bushing	062	Large Idler Gear
014	Adjusting Screw	064	Thickness Pointer
015	Spacer Bar	067	Spacer Strap
015P	Lock Washer	112	Chain Cover
015S	Hex Head Screw	113	Gear Cover
016	Riser Block	113S	Round Head Screw
018D	Hex Head Bolt	210	Sprocket Gear
018N	Hex Nut	210S	Socket Head Set Screw
018U	Hex Head Bolt	211	Chain
018W	Washer	313	Handwheel
019	Spacer	313A	Handle
019N	Hex Nut	313N	Hex Nut
019S	Round Head Screw	313S	Socket Head Set Screw
019W	Washer		
024A	Gear End Housing		
024B	Crank End Housing		
026	Spacer Strap		
030D	Bottom Roller		
030P	Pin		
030S	Hex Head Screw		
030W	Washer		

Slab Roller

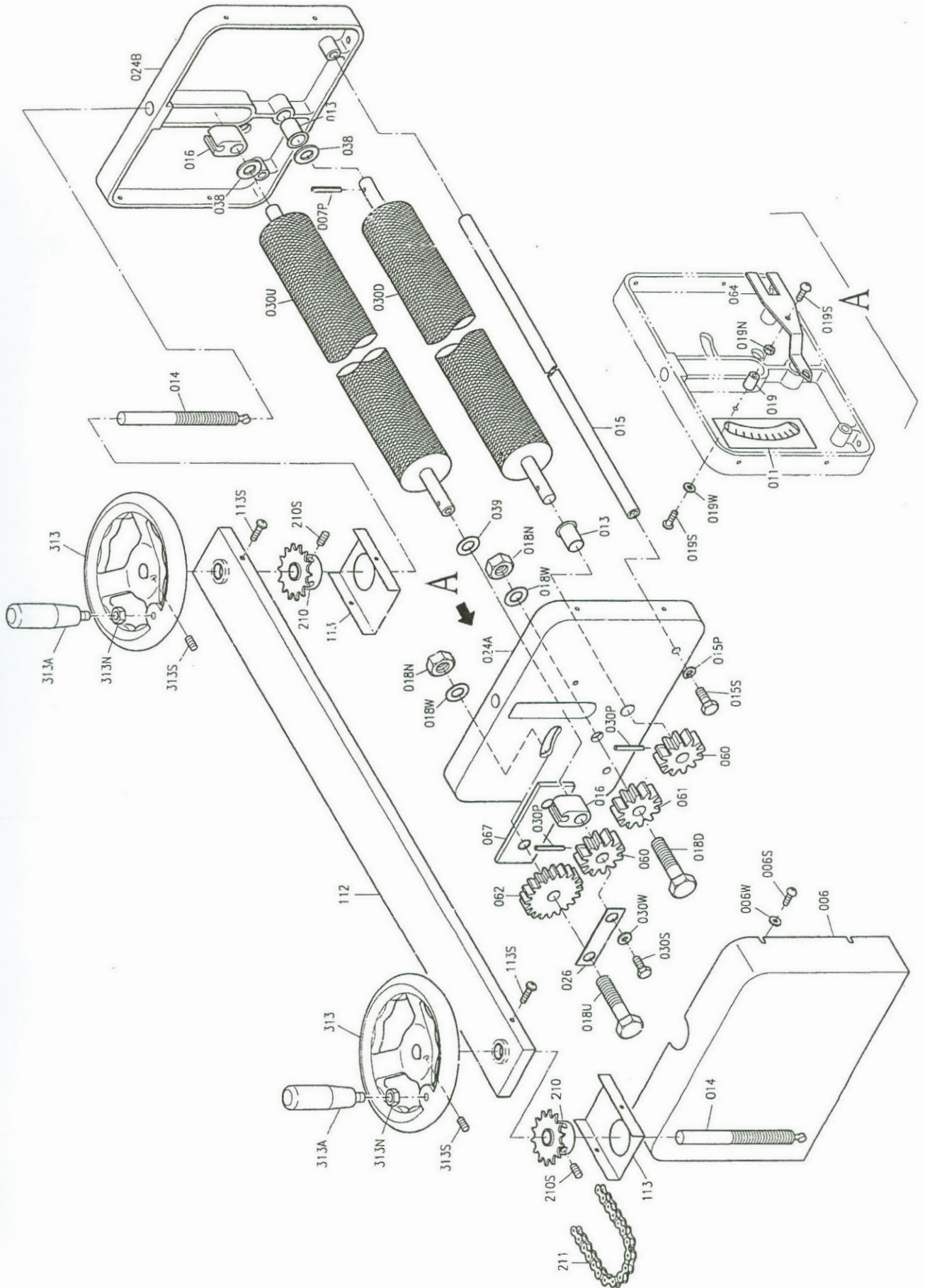

Frame Assembly & Table Top

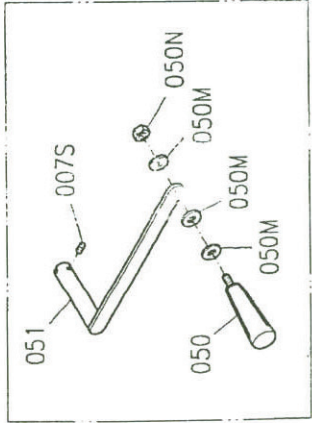
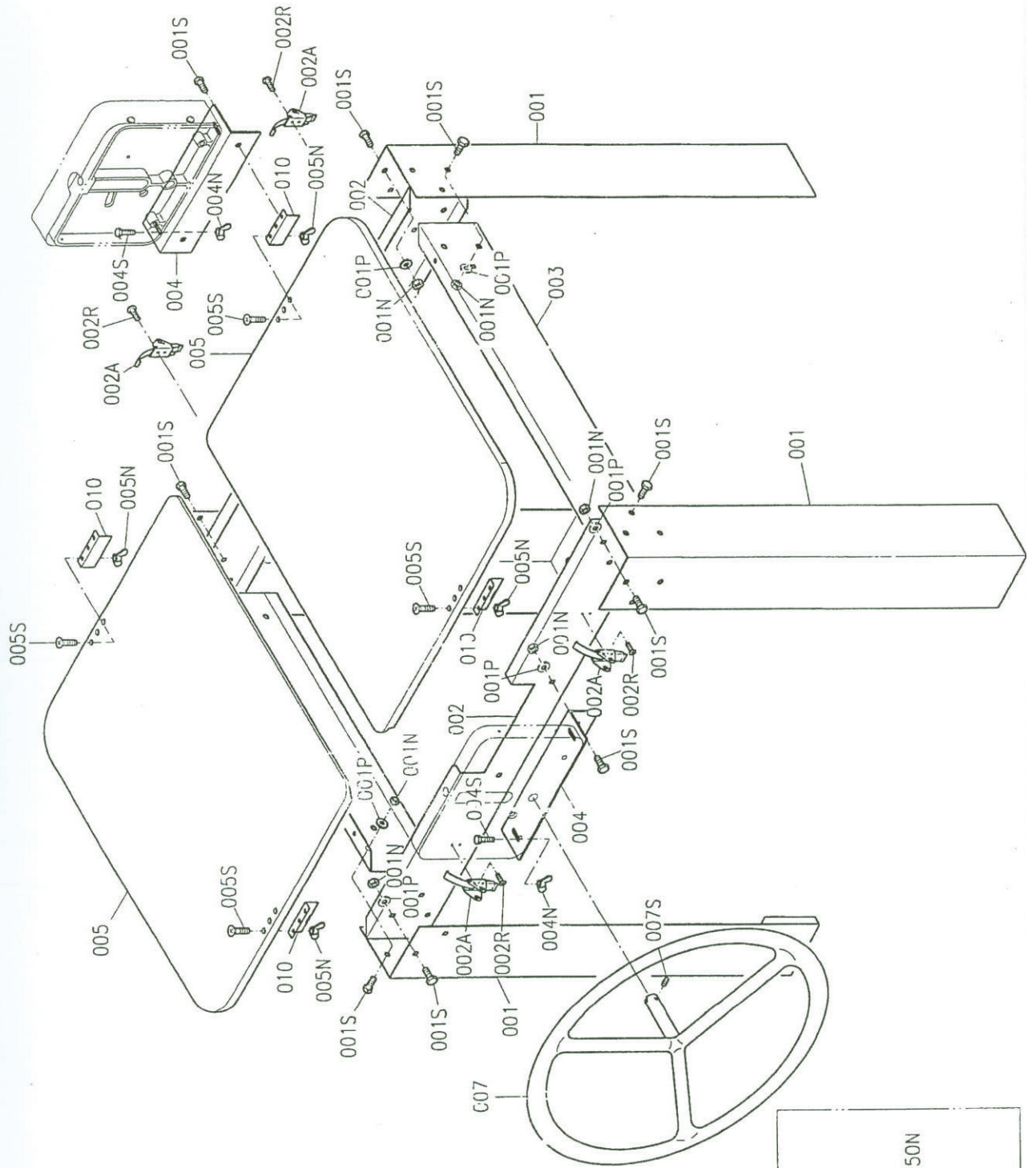

SHIMPO All for dreams

NIDEC-SHIMPO AMERICA CORPORATION • Itasca, IL 60143 USA • Phone: (800) 237-7079 • (630) 924-7138 • Fax: (630) 924-0340
www.shimpoceramics.com • info@shimpoceramics.com