

SHIMPO Pug Mill

Instruction Manual



NRA-04
NRA-04S

Please make sure to read the entire instruction manual thoroughly before initial set-up, operation, maintenance and inspection to ensure proper use.

Please keep this instruction manual in a location that is available to the user.

SHIMPO

A *Nidec* Group Company

NIDEC-SHIMPO AMERICA CORPORATION • 1701 Glenlake Avenue Itasca, IL 60143 USA • Phone: (800) 237-7079 • Fax: (630) 924-0340
www.shimpoceramics.com

Contents

| | |
|---------------------------|---|
| Safety precautions | 1 |
| Specifications | 4 |
| List of contents | 4 |
| Installation Instructions | 5 |
| Operating Instructions | 6 |
| Maintenance Instructions | 7 |
| Warranty Provisions | 9 |
| Disposal Method | 9 |

SAFETY PRECAUTIONS

Please make sure to read the entire instruction manual thoroughly before initial set-up, operation, maintenance and inspection to ensure proper use.

Please start using only after you have read the equipment's function, safety information and precautions.

This instruction manual provides three grades of safety warnings: "Danger", "Warning" and "Caution". All precautions described here under which concern to the safety are to be read carefully. Please be sure to follow them.



Danger marking indicates possible death, severe injury or fire if the user disregards the instruction.



Warning marking indicates the possibility of severe injury if the user does not follow the instruction.



Caution marking indicates the possibility of minor or damage if the user operates the pug mill improperly. However, depending on the circumstances, it is still possible to cause severe injury. Please make sure to pay close attention to these warnings.

We call your attention to these warnings throughout the manual using the following symbols:



Warning; Pay Close Attention



Do Not



Please Follow Instructions

DANGER



These are safety precautions regarding with installation of pug mill.

Installation



Do not set up in a location that is susceptible to rain and water or an area of high moisture.

This may cause a fire or failure form electrical shock or electrical leakage.



Do not overload the electrical outlet.

Check the amperage rating of the outlet and of any other equipment that may be on the same circuit. A fire could result from overloading the circuit.

Operation



Do not let anyone operate the pug mill without proper instructions and supervision.

Please assign a specific person to supervise the use of the pug mill in facility where many people operate the unit. Make especially sure not to let children operate the pug mill.



Do not insert hands.

Please do not insert hands into the clay hopper or clay nozzle. Serious injury could occur.



Be careful of clothing.

Loose fitting ties aprons and other clothing may hang into clay hopper clay nozzle and become entangled in the internal moving parts causing serious injury.



Secure long hair away from pug mill.

Serious injury may occur if a person's hair becomes entangled in the internal moving parts.



Do not operate any switches with wet hands.

This may cause an electrical shock if you operate switches or plug / unplug cord into the power outlet.

MAINTENANCE

Maintenance These are safety precautions regarding the maintenance of pug mill.



Switch the power off before doing any inspection. Unplug the power cord.

Please make sure to switch the power off and unplug the power cord from the outlet before doing any cleaning, inspection, adjustment, or moving the pug mill.



Unplug the power cord carefully by pulling the power plug, not the power cord.

Do not pull on the cord when you unplug the power cord. This may cause damage to the cord and/ or plug, which could also, result in a fire created by an electric short or injury from an electrical shock.



Do not use damaged power cord

Please do not use damaged power cord, damaged plug or worn power outlet. It may cause a fire due to an electrical shock or electrical short.

WARNING



Installation These are safety precautions regarding with installation of the pug mill.



Place the pug mill on a flat horizontal surface.

Please make sure to place pug mill unit on a horizontal surface since bumps and slopes may cause vibration and noise. Please make sure to tighten the lock nut on the adjustable leg after adjusting the height.

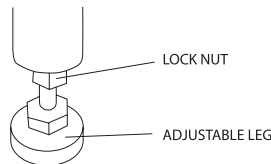

Be careful with handling since this product is heavy.

Please handle pug mill with extreme care since serious injury can occur if the unit should fall on (hands or feet) body parts.

CAUTION



Operation

These are safety precautions regarding with operation of the pug mill.



Please turn the power switch off if you will not be using the pug mill for an extended period of time.

If you will not be using the pug mill for a long period of time please switch the power off and unplug the power cord from the outlet to prevent damage from possible power surge such as a lightning strike.

Maintenance

These are safety precautions regarding the maintenance of pug mill.



Do not pour water on pug mill to clean it.

Please do not pour water on pug mill to clean it. This may cause an electric short or damage to the pug mill. Clean off pug mill with a damp cloth. The clay hopper, screw case, and nozzle are washable only after disassembly.

SPECIFICATIONS

| Model | NRA-04 | NRA-04S |
|----------------------------|--|---------------------------|
| Dimension | 25 1/2" (40" Including Plate) x 12" x 22 1/2" Height | |
| Weight | 144 lbs | 166 lbs |
| Anger Rotation | 20 rpm / 60Hz | 20 rpm / 60Hz |
| Motor | 200W 4P Single Phase 115V | 200W 4P Single Phase 115V |
| Extruding Capacity | 880 lbs / hour | 880 lbs / hour |
| Structure | Twin Anger | Twin Anger |
| Anger material | Stainless Steel | Stainless Steel |
| Anger Case Material | Aluminum | Stainless Steel |
| Nozzle Diameter | 3 1/2" | 3 1/2" |

LIST OF CONTENTS

| Description | Quantity | Reference |
|---------------------------|----------|---------------------------------|
| Drive Housing | 1 | |
| Clay Roller Shelf | 1 | |
| Hopper Cover | 1 | Cover for Clay Hopper |
| Front Cover | 1 | Cover for Nozzle Opening |
| Wrench | 1 | |
| Double-head Wrench | 1 each | |
| Allen Wrench | 1 | |
| Bolt | 2 | M10 x 1" for screw case removal |
| Instruction Manual | 1 | |
| Warranty Card | 1 | |

■ Pug Mill Diagram

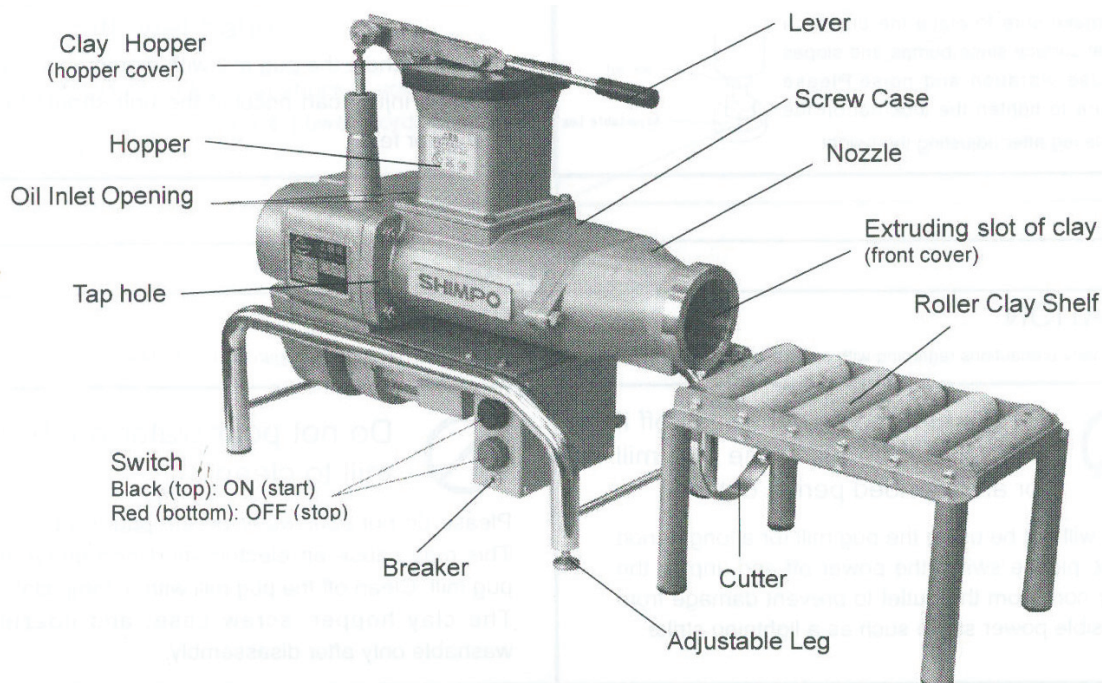

INSTALLATION

■ Installation

1. Remove the front cover and hopper cover.
2. Place the roller clay shelf in front of the nozzle.
3. Loosen lock nut on adjustable leg.
4. Set the adjustable leg level on the pug mill and allow all four feet on frame to touch the surface.

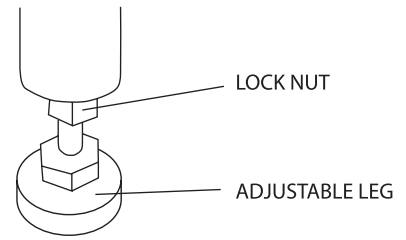

OPERATION

■ Operation

Precautions

- * Do not operate any switches with wet hands.
- * Do not insert hands or body parts into any opening on the pug mill.
- * The breakers may shut down by overloading if you forcibly operate the lever. (Operation of Breaker, refer to P. 8)
- * In the event that dry clay remains in the clay hopper, please remove the nozzle and clean the internal parts. (Disassembly Procedures, refer to P. 7)
- * Please do not put a chunk of dry clay or clay refuse into the clay hopper.
- * Before placing clay into the hopper clay, please be sure to add water into the clay in order to put in the condition that you can knead by hands. Otherwise, screw may stop and clay may not mix well.

1. Switch the power on.
2. Pull the lever up (screw stop). Place clay into the clay hopper in small amounts.
3. Pull the lever down (screws rotate).
4. When the lever is all the way down it can be lifted back up to place more clay in clay hopper. Continue with this process until you have proceeded all of your clay.
5. Switch the power off when you are finished processing clay.
6. Pull the lever down.
7. Unplug the power cord from the outlet.

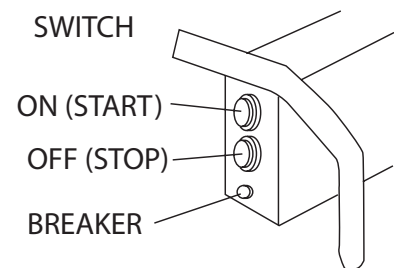

■ After Operation

1. Pull the lever down and install the hopper cover over the clay hopper.
2. Install the front cover over the end of the pug mill nozzle.

Precautions

- * Never operate the pug mill with dry clay remaining in the main body.
- * When total cleaning of the pug mill is desired clean internal parts of the main body by following the disassembly procedures (Disassembly Procedure, refer to P.7).

Please do not leave clay in the main body for a long period if time. Just in case dry clay remains in Drive housing, do not operate the pug mill in such a condition. Please disassemble the pug mill and remove the clay (Disassembly Procedures, refer to P.7).

MAINTENANCE

■ Cleaning

* When total cleaning of the pug mill is desired clean the internal parts of the main body by following the disassembly procedures.

□ Disassembly Procedures

1. Switch the power off.
2. Unplug the power cord from the outlet.
3. Remove the hopper cover and front outlet.
4. Remove two nuts that secure the nozzle to the screw case using the wrench supplied. Then remove the nozzle from screw case.
5. Remove the four bolts that secure the clay hopper to the screw case using the wrench supplied.
6. Remove screw case by detaching four nuts that secure the screw case to the drive housing using the wrench supplied.

Precautions

*Rinse each of the disassembled parts with water and dry them well. Do not disassemble parts, which are not described, since this may cause the pug mill to fail and will void the warranty.

Disassembly Diagram

In the event that it is difficult to remove hard clay remaining in screw case for an extended period thread the 1" bolt into the tapped holes at the rear of the screw case to gently pry the screw case from the drive housing

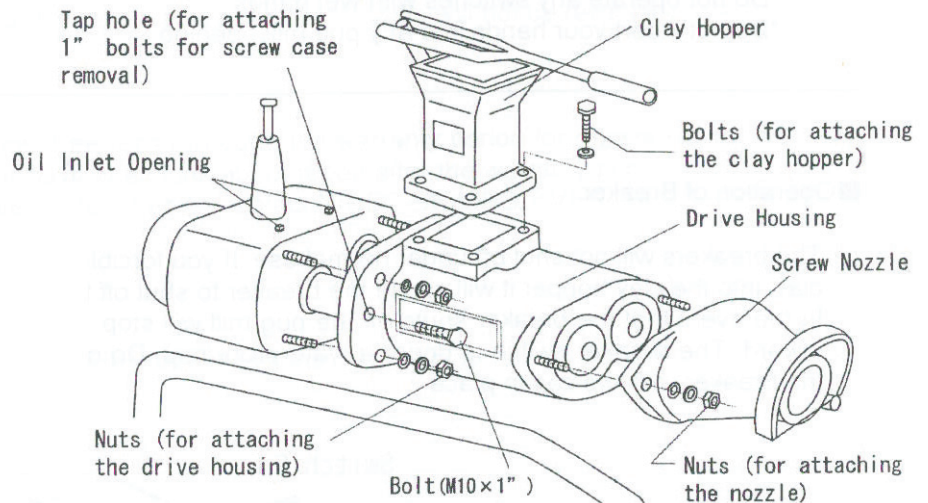

■ Oil Inlet Opening

1. Pull the lever down and install the hopper cover over the clay hopper.
2. Install the front cover over the end of the pug mill nozzle.

Precautions

*Fuel oil or grease is not suitable for lubrication.
*Please do not inject unknown substances or water into the oil inlet opening.

MAINTENANCE

□ Assembly Procedures

1. Install the screw case into the drive housing and tighten with nuts for attaching the screw case.
2. Install hopper onto the screw case and tighten with bolts for attaching the clay hopper.
3. Install nozzle onto the screw and tighten with nuts for attaching the nozzle.
4. Pull the lever down, plug the power card into the outlet, and switch the power on. Check for unusual sounds. Recheck assembly if necessary.

■ Trail Operation

1. Plug the power cord into the outlet.
2. Do not set anything into the clay hopper, pull the lever down, switch the power on, and then allow the unit to run for a short time.
3. Check if the pug mill has any vibration, rattles, or unusual sounds (If none then proceed to the section on operation).
4. Switch the power off and unplug the unit.
5. Make adjustments to level and position the pug mill.
6. Return to step one.

Precautions

- *Do not operate any switches with wet hands.
- *Do not insert your hands into any pug mill opening.

■ Operation if Breaker

The breaker will not shut off under normal use. If you forcibly push a large amount of clay, or hard clay, into the hopper it will cause the breaker to shut off the pug mill. In the event that the breaker shuts off the pug mill will stop. In this case press the breaker switch inward, the breaker switch is under a waterproof cap. Do not remove the water cap. Press the breaker with the cap in place.

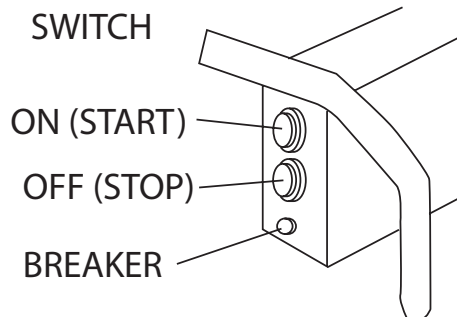

WARRANTY PROVISION

■ Cleaning

*Shimpo warrants that this product shall be free from defects in workmanship and materials under normal use and proper maintenance for the warranty period specified providing that you follow the instruction manual and information printed on the label attached to the main body.

*The following cases are not covered under the warranty:

Breakdown or damage caused by misuse or alternation.

Breakdown by damage caused by dropping the unit.

Breakdown or damage caused by fire, earthquake, flood damage, power surges and other natural disasters.

Breakdown or damage cause by public pollution, gas, pollution, salt damage, and unusual electric disturbances.

Changes in apparent condition such as scratches obtained through use and storage.

Failure to submit the warranty card.

*Please keep the warranty card in a safe place. Warranty cards will not be reissued.

*The warranty card guarantees free repair through the warranty period for repairs falling within the terms of the warranty. If you have any questions about repairs after the warranty period, please consult an authorized Shimpo dealer or feel free to contact Nidec-Shimpo America Corporation directly.

*Please become familiar with the terms and conditions of the warranty.

DISPOSAL METHOD

*Please consult with local government since the disposal method for the pug mill is different in each local government.

*Please do not disassemble the pug mill when you dispose of it.

Please make sure to read thoroughly to ensure safe and proper operation of the pug mill.

Please make sure to read thoroughly to ensure safe and proper operation of the pug mill.

- 1. Assign a designated person to supervise the safe and proper use of the pug mill in facilities where the unit will be used by more than one person. Restrict the use of pug mill to only properly trained individuals.**
- 2. Do not let children operate the pug mill.**
- 3. Do not insert your hands into any opening in the pug mill.**
- 4. Switch the power off and unplug the power cord from the outlet when you clean and disassemble. Never rotate the motor while disassembling.**
- 5. Do not wear loose fitting clothing like neckties or aprons, which may get caught, in the moving parts in the pug mill.**
- 6. Secure long hair up and away from the pug mill.**
- 7. Do not operate any switches with wet hands.**

Product by
NIDEC-SHIMPO AMERICA CORPORATION

SHIMPO

A Nidec Group Company

NIDEC-SHIMPO AMERICA CORPORATION • 1701 Glenlake Avenue Itasca, IL 60143 USA • Phone: (800) 237-7079 • Fax: (630) 924-0340
www.shimpoceramics.com