

OUT

OBJEKTE UNSERER TAGE

X-CHAIR



STILLFRIED
WIEN

www.stillfried.com / office@stillfried.com / T +1 212 226 2921 / 40 WALKER STREET, 10013 NEW YORK

BRUTAL HERE AND NOW RECYCLING CIRCUIT & RESPONSIBILITY

The X-CHAIR by OUT is made from 100% recycled polypropylene and sets new standards. Currently on the market, so-called recycling furniture contains a maximum of 1-30%. Given the ecological situation, this is not enough for OUT.

The sustainability concept for the X-CHAIR goes further; clients can return the chair to OUT years later. It is then processed into granules and goes back into the production cycle.

Ecological responsibility cannot be without social responsibility - so local production in a medium-sized family business, 80 km from Berlin, is a matter close to the heart for OUT. It is part of OUT's worldview to create serial objects that are produced regionally and fairly. Responsible design - brutally arrived in the here and now.

STUDENT AND MASTER PASSION AND TEACHING

The cooperation between Hermann August Weizenegger and OUT is a naturally grown connection. OUT co-founder and designer David Spinner was a student of HAW at the University of Applied Sciences in Potsdam during his product design studies. Some of David Spinner's designs that made their way into the OUT collection date from this period. This is evidence of the intense imprint from this phase.

The relationship, based on respect and friendship, has existed ever since. A particularly fruitful connection for OUT, as the X-CHAIR from HAW complements the collection in a meaningful way and symbolizes its anchoring in the city of Berlin. HAW answers the question of why the X-CHAIR belongs to OUT with a picture: *"In the case of OUT, I made a conscious decision because I feel a dynamic and appreciate the pioneering spirit of moving something in a very static market. For me, OUT is like a catamaran that sails nimble and agile in front of a big ocean liner."*

DESIGN

Hermann August Weizenegger, 2020

MATERIAL

100% recycled polypropylene

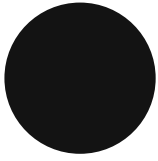

Black

DIMENSIONS

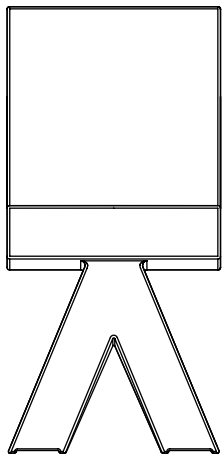

40 cm

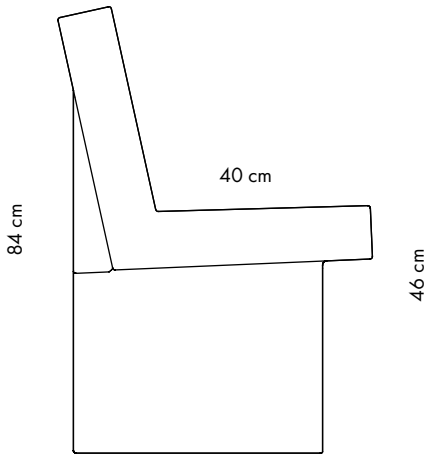

84 cm

40 cm

46 cm

59 cm

Back

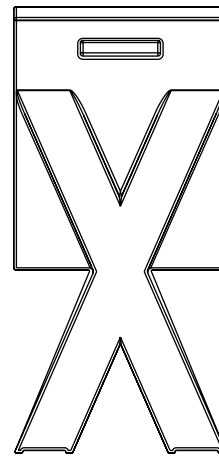

84 cm

40 cm

ABOUT OUT

OUT OBJEKTE UNSERER TAGE was founded in 2015 with the ambition to create space for a self-terminated generation. Our goal is to create furniture and accessories that meet the needs of our time and have a practical and emotional value. OUT stands in the tradition of German design. We act with great care, design thoughtfully and think functionally. Our objects are manufactured fairly and sustainably in Germany. Each object embodies craftsmanship and sophistication. Our home is Berlin. The city decisively shapes our design. We are passionate, dare to innovate, and enjoy diversity. The result is an eclectic collection of substance: clear, straightforward and uncompromising in design, yet pure, expressive and consistent in its implementation. We celebrate the real life and the beautiful.



DESIGNED IN BERLIN
MADE IN GERMANY

OUT
OBJEKTE UNSERER TAGE