



KALMAR[®]
WERKSTÄTTEN

Zweig

STILLFRIED
WIEN

40 WALKER STREET, 10013 NY T 212 226 2921

OFFICE@STILLFRIED.COM WWW.STILLFRIED.COM



Polished Brass | Silk

Zweig Wall Lamp

Conceived by J.T. Kalmar for anterooms, corridors, or as accent lighting, this early-1950s double sconce produces soft ambient and downlight. Two shades are finished in natural, textured silk. Milled wall plate and metal arms can be specified in one of four finishes: polished brass, black bronze, matt black lacquer or polished nickel.

DIMENSIONS

in mm

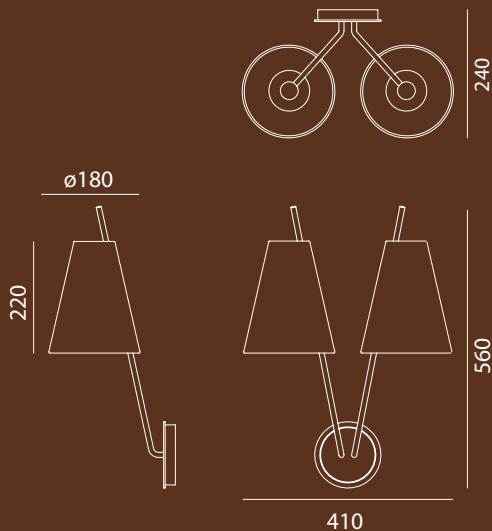

MATERIAL OPTIONS

Metal

Polished Brass
 Black Bronze with Highlighted Edges
 Matt Black Lacquer
 Polished Nickel

Shade

Silk

Electrical Specifications

2 x E14 40W

Weight

1.7 kg

©2015 These designs are the exclusive property of J.T. Kalmar GmbH and may not be copied or adapted for this or any other use without express written permission



Polished Brass | Silk



Black Bronze with Highlighted Edges | Silk



Black Bronze with Highlighted Edges | Silk