

KALMAR®
WERKSTÄTTEN



Hallstatt

STILLFRIED
WIEN

40 WALKER STREET, 10013 NY T 212 226 2921

OFFICE@STILLFRIED.COM WWW.STILLFRIED.COM



Rosewood | Black Bronze with Highlighted Edges

Hallstatt Pendant

Designed more than two decades after the launch of the Admont and Holzstern luminaires, the chandelier Hallstatt is a specific adaptation of those predecessors to entrance areas and small lobbies. In addition to providing consumers with a 1.85-meter-diameter light fixture, J.T. Kalmar used Hallstatt as an opportunity to reinterpret armature design as a stable latticework made of rosewood, wenge, oak, hardwood or walnut finished in a wax coating or matt black lacquer.

DIMENSIONS

in mm

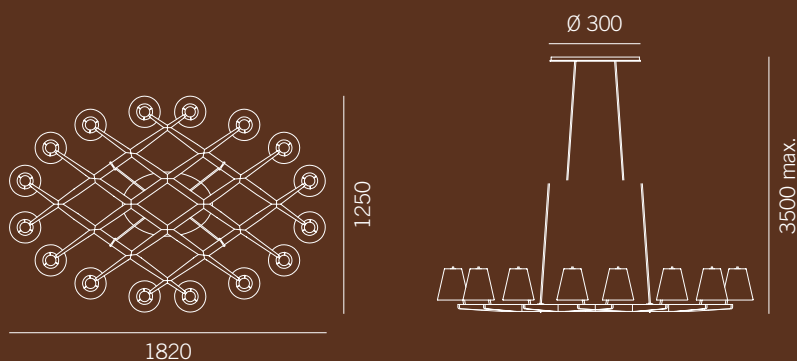

MATERIAL OPTIONS

Wood | Metal

- Rosewood | Black Bronze with Highlighted Edges
- Wenge | Black Bronze with Highlighted Edges
- Hardwood, Satin Matt Black Lacquer | Matt Black Lacquer
- Oak | Matt Black Lacquer
- Oak | Black Bronze with Highlighted Edges
- Walnut | Black Bronze with Highlighted Edges

Shade

Silk

Cable

Black Color Textile

Electrical Specifications

16 x E27 40W

Weight

17 kg

©2015 These designs are the exclusive property of J.T. Kalmar GmbH and may not be copied or adapted for this or any other use without express written permission