

Electrolux

ELECTROLUX HOME PRODUCTS PTY LTD

ABN 51 004 762 341

Technical Publication Nº RE1083

Issue: 1

Date 6/20

PARTS & VIEWS WESTINGHOUSE

Bottom Mount Four Door Electronic 90 Wide Refrigerator Black Stainless “B” Series



MODEL / PNC

WQE6000BB – 925060883

WQE6060BB – 925060884

MAINTENANCE LEVEL CHANGE SUMMARY

ML	Description	Product Release Date
00	00	09/2018

MODEL NUMBER IDENTIFICATION

FREE STANDING COOKERS										
W	B	E	S	#	#	#	W	A	R	
Brand	Construction	Oven Fuel Type	Added Features	Width	Hob Type	Specification Level	Colour	Series	Side Opening Door Type	Gas Type
W = Westinghouse C = Chef E = Electrolux Z = Zanussi S = Simpson	E = Elevated Cooker F = Front Control Freestanding Cooker L = Rear Control Freestanding Cooker	E = Electric G = Gas	Leave blank for all except the below: S = Side Opening Door P = Pyro	5 = 80 - 84cm 6 = 80 - 89cm 7 = 70 - 78cm 8 = 80 - 89cm 9 = 90 - 99cm 1 = 100cm and above	IF FUEL TYPE = G 0 = No wok 1 = Wok IF FUEL TYPE = E 2 = Radiant Coil 3 = Solid 4 = Ceramic 5 = Induction 6 = Dual fuel	Even = G10, D10 = Sep Grill 0 = Lowest Spec 1 2 3 4 5 6 7 8 9 = Highest Spec	W = White S = Stainless Steel B = Black	A = SAFR B = 1st series change C = 2nd series change etc	L = Left Hand Opening R = Right Hand Opening	LP = Liquefied Petroleum NG = Natural Gas
BUILT-IN OVENS										
W	B	E	S	#	#	#	W	A	R	
Brand	Construction	Oven Fuel Type	Added Features	Width	Cavity Type	Specification Level	Colour	Series	Gas Type	Side Opening Door Type
W = Westinghouse C = Chef E = Electrolux Z = Zanussi S = Simpson	V = Built-in oven	E = Electric G = Gas	Leave blank for all except the below: S = Side Opening Door M = Microwave P = Pyro	3 = 30cm - 36cm 4 = 40cm - 49cm 5 = 50cm - 59cm 6 = 60cm - 69cm 7 = 70cm - 79cm 8 = 80cm - 89cm 9 = 90cm - 99cm 1 = 100cm - 110cm 2 = 120 cm +	1 = Single 2 = Duo 3 = Double 4 = Combo Oven 5 = Sep grill und bench 6 = Sep grill wall oven 7 = Compact	0 = Lowest Spec 1 2 3 4 5 6 7 8 9 = Highest Spec	W = White S = Stainless Steel B = Black	A = SAFR B = 1st series change C = 2nd series change etc	LP = Liquefied Petroleum NG = Natural Gas	L = Left Hand Opening R = Right Hand Opening
BUILT-IN HOB'S										
W	B	#	#	#	#	W	A			
Brand	Construction	Hob Type	Width	No. Burners/Zones	Specification Level	Colour	Series			
W = Westinghouse C = Chef E = Electrolux Z = Zanussi S = Simpson	H = Hob	IF ELECTRIC HOB: S = Solid C = Ceramic I = Induction R = Radiant Coil M = Mix IF GAS HOB: G = Gas D = Dual Fuel	3 = 36cm or below 4 = 40cm - 49cm 5 = 50cm - 59cm 6 = 60cm - 69cm 7 = 70cm - 79cm 8 = 80cm - 89cm 9 = 90cm - 99cm 1 = 100cm - 110cm 2 = 120 cm and above	1 2 3 4 5 6 7 8 9	0 = Lowest Spec 1 2 3 4 5 6 7 8 9 = Highest Spec	W = White S = Stainless Steel B = Black	A = SAFR B = 1st series change C = 2nd series change etc			

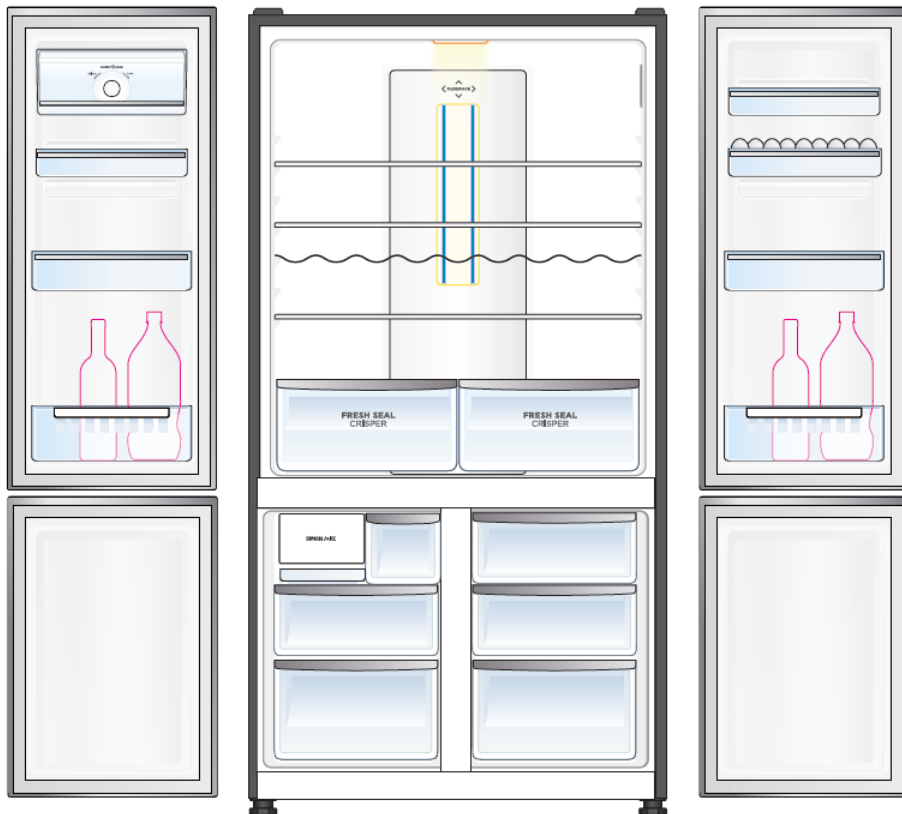

CONTENTS

MAINTENANCE LEVEL CHANGE SUMMARY2

MODEL NUMBER IDENTIFICATION.....2

 REFERENCES.....4

 Complete Door Panels4

 ABBREVIATIONS4

BLOCK DIAGRAM / WIRING DIAGRAM.....17

 WQE6000BB-D 92506066317

 WQE6060BB-D 92506039618

EXPLODED VIEWS & PARTS LISTS

MODEL: WQE6000BB & WQE6060BB5

 COMPRESSOR COMPARTMENT.....5

MODEL: WQE6000BB6

 DOOR AND INTERIOR.....6

MODEL: WQE6060BB8

 DOOR AND INTERIOR.....8

MODEL: WQE6000BB & WQE6060BB10

 INTERNAL FRIDGE SECTION10

MODEL: WQE6000BB & WQE6060BB12

 SYSTEM FREEZER.....12

MODEL: WQE6000BB & WQE6060BB14

 INTERNAL FREEZER SECTION14

MODEL: WQE6060BB16

 ICE AND WATER COMPONENTS16

NOTE: In Parts Listings

N.I.	=	Not Illustrated
N.P.A.	=	No Part Available
N.P.N.	=	Not Used on this Model

REFERENCES

Complete Door Panels			
A17859703	DOOR SPARE FZR L+R WQE6000BB	WQE6000BB	925060663
A17859704	DOOR SPARE FZR L+R WQE6060BB	WQE6060BB	925060664
A17859705	DOOR SPARE FC LH + RH WQE6000BB	WQE6000BB	925060663
A17859706	DOOR SPARE FC LH + RH WQE6060BB	WQE6060BB	925060664

ABBREVIATIONS

70	400LTR RANGE 70CM WIDE CABINET
80	500LTR RANGE 80CM WIDE CABINET
ASSY	ASSEMBLY
BF	BOTTOM FREEZER
EL	ELECTROLUX
FC	FRIDGE COMPARTMENT
FD	FRENCH DOOR
FR	FRONT
FRZ	FREEZER COMPARTMENT
I&W	ICE AND WATER
IDP	INNER DOOR PANEL
KL	KELVINATOR
LH	LEFT HAND
LWR	LOWER
MD	MULTI DOOR FRIDGE
NPN	NO PART NUMBER
PCB	PRINTED CIRCUIT BOARD
RH	RIGHT HAND
SD	SINGLE DOOR
SXS	SIDE BY SIDE FRIDGE FREEZER
TF	TOP FREEZER
UPR	UPPER
WH	WESTINGHOUSE

MODEL: WQE6000BB & WQE6060BB

COMPRESSOR COMPARTMENT

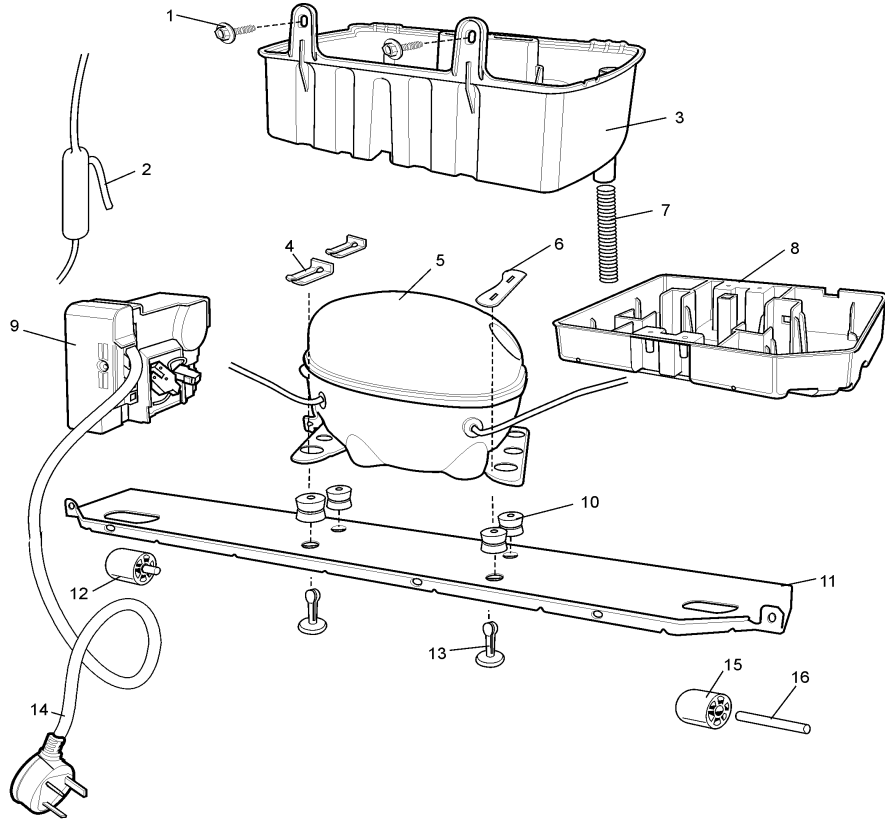

ITEM	PART N°	PART DESCRIPTION	QTY
1	808199001	SCREW SELF TAPPING 6X20	2
2	ES5332	DRIER 12 MG WITH TAIL	1
3	A03906202	DRAIN PAN COMPRESSOR WITH TUBE HEATER	1
4	A04326602	CLAMP COMPRESSOR	2
5	A01451902	COMPRESSOR JAIX VNX1113Y	1
6	811998601	CLAMP COMPRESSOR SINGLE	1
7	A02359903	TUBE CORRUGATE BF	1
8	A03978306	DRAIN PAN OVERFLOW WITH HEATER TUBE	1
	A10080806	HEATER TUBE O/FLOW PAN	1
	A02830303	HEATER TUBE COMP DRAIN PAN	1
9	808364715	PCB INVERTER DRIVE FLEX 1	1
10	811978901	MOUNT, COMPRESSOR	4
11	807822709	BASE PLATE (INC. 15&16)	1
13	N.P.N.	PIN MOUNT COMPRESSOR (PART OF BASE)	
14	A03593401	POWER CORD INVERTER REF AU/NZ	1
15	811998205	ROLLER FOOT	2
16	811998301	AXLE, ROLLER	2
NI	A02052203	TUBE JUMPER H/X	1
NI	808293603	TUBE PROCESS	1
NI	811976001	VALVE DRAIN ASSY BF	1

MODEL: WQE600BB

DOOR AND INTERIOR

Ex 8456

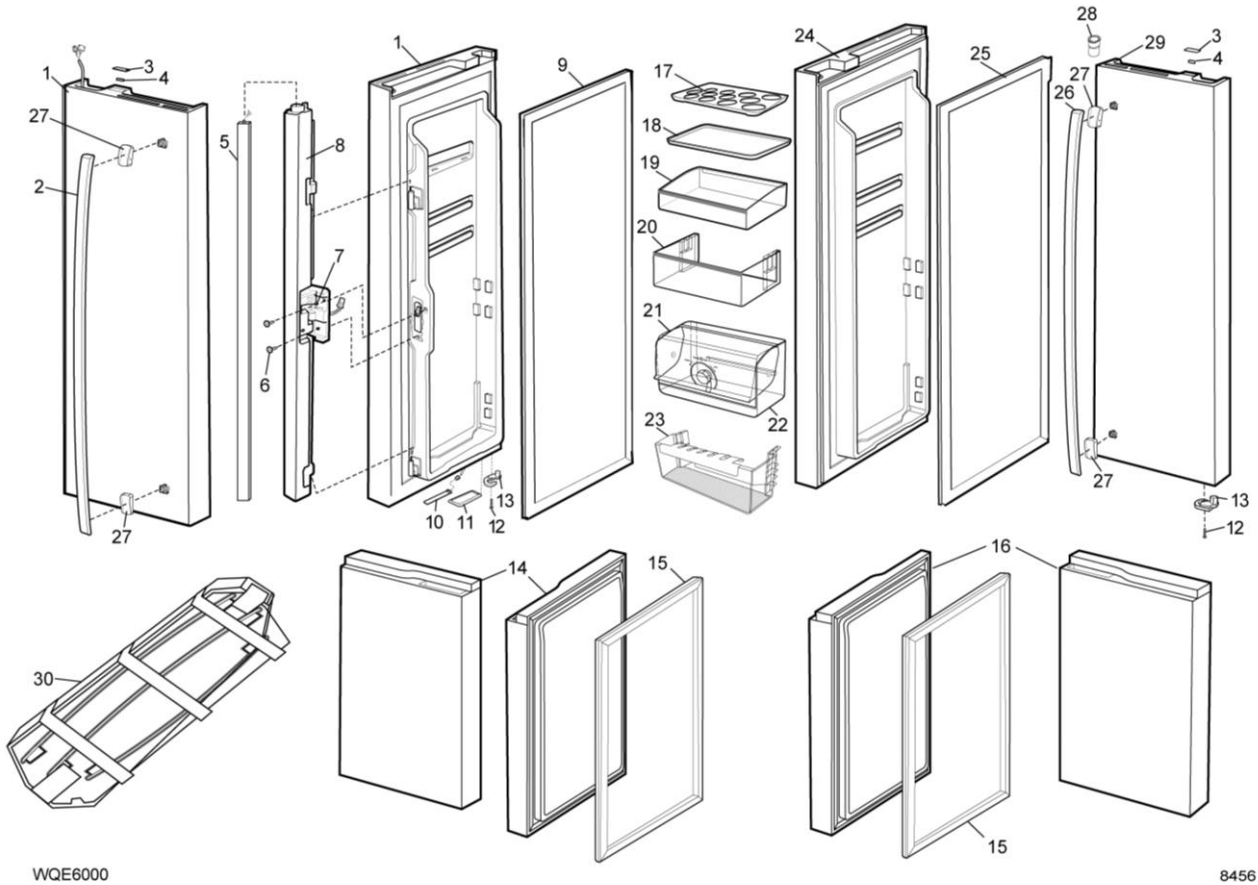

WQE6000

8456

ITEM	PART N°	DESCRIPTION	8456	WQE6000
1	A17859705	DOOR KIT FC LH + RH (2 FRIDGE DOORS)		1
2	A01882518	HANDLE ASSY MD KIT BLK (INC. ITEMS 2, 26 & 27)		1
3	A01748901	COVER MAGNET ENDCAP MD80 GR		2
4	A02677501	MAGNET FOR REED SWITCH		2
5	A01376301	HEATER FLIP MULLION MD		1
6	1449412	SCREW		2
7	A01376201	HINGE FLIP MULLION MD		1
8	A01321401	MULLION FLAP MD		1
NI	A01371901	SPRING FLIP MULLION		1
9	811988556	GASKET FC MD90		2
10	N.P.N	NOT USED IN THIS MODEL		
11	N.P.N	NOT USED IN THIS MODEL		
12	808337901	SCREW		2
13	A01046504	BEARING AUTO CLOSER LH		1
	A01046502	BEARING AUTO CLOSER RH		1
14	A17859703	DOOR SPARE FZR L+R (2 FREEZER DOORS)		1
15	811988585	GASKET FZR RH/LH		2
16	A17859703	DOOR SPARE FZR L+R (2 FREEZER DOORS)		1
17	A00807802	TRAY EGG 80W		1
18	N.P.N.	NOT USED IN THIS MODEL		
19	A00804207	BIN DOOR FLEX 80 1-HOTFOIL		3
20	A05205803	BIN DOOR FC SHAL MD90HOTFO PE		2
*21	A12956502	BIN DOOR DAIRY LID 80 EL-ART		1
*22	A00806002	BIN DOOR DAIRY BODY TF80 EL		1
23	A04953503	BIN DOOR FINGER MD90 ASSY		2
24	A17859705	DOOR KIT FC LH + RH (2 FRIDGE DOORS)		1
25	811988556	GASKET FC MD90		1
26	A02331110	HANDLE ASSY MD KIT		1
27	REFER ITEM 2	PEDESTAL INCLUDED IN ITEM 2		
28	A01069002	BEARING HINGE (FZR) TOP CLOSED		1
29	N.P.N.	NOT USED IN THIS MODEL.		
30	REFER ITEM 2	HANDLE ASSY MD KIT (INC. ITEM'S 2, 26 & 27)		1
NI	A12387601	BADGE WESTINGHOUSE		1

*NOTE: Items 21 & 22 are also available as P/N: A00803106, BIN DOOR LOCKABLE COMPLETE ASSY.

MODEL: WQE6060BB

DOOR AND INTERIOR

Ex 8455

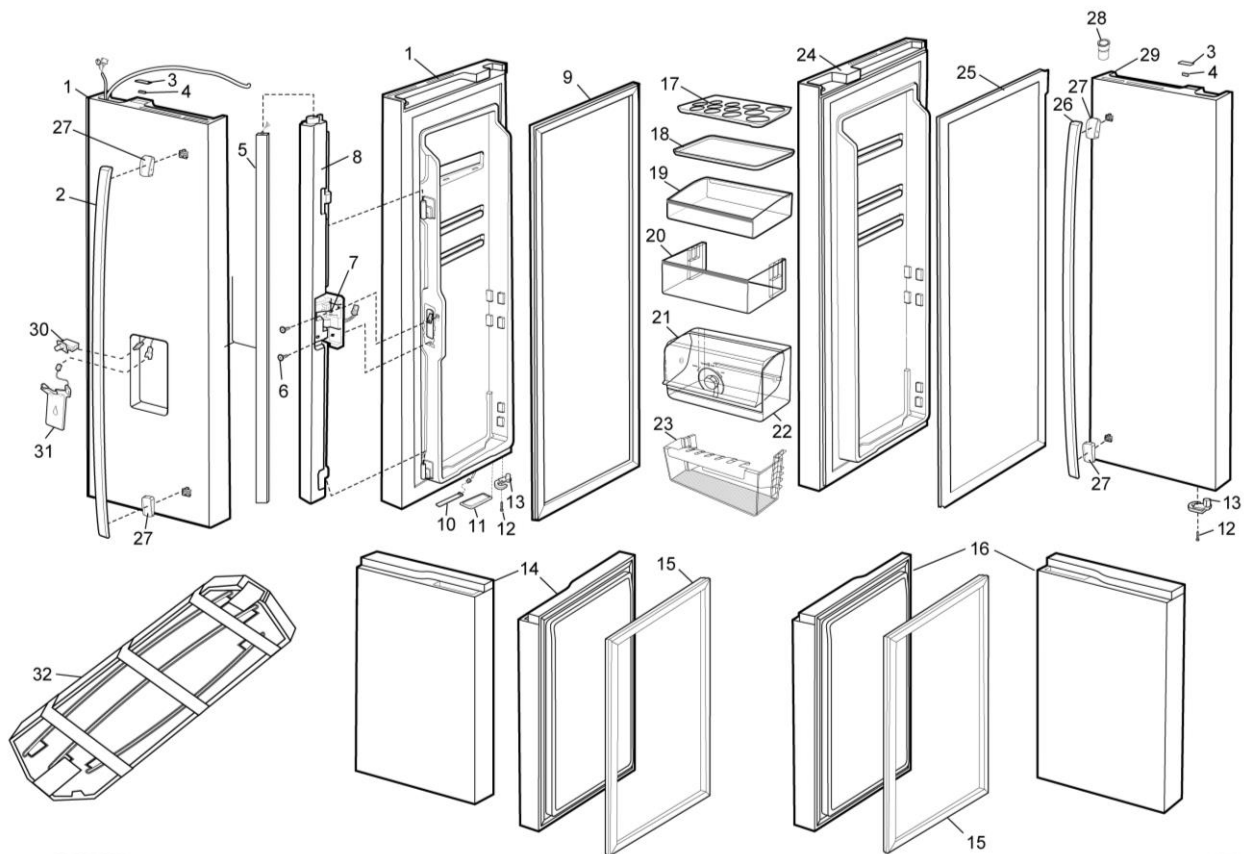

WQE6060

8455

ITEM	PART N°	DESCRIPTION	8455	WQE6060
1	A17859706	DOOR KIT FC LH + RH (2 FRIDGE DOORS)		1
2	A01882518	HANDLE ASSY MD ELUX KIT BLK (INC. ITEMS 2, 26 & 27)		1
3	A01748901	COVER MAGNET ENDCAP MD80 GR		2
4	A02677501	MAGNET FOR REED SWITCH		2
5	A01376301	HEATER FLIP MULLION MD		1
6	1449412	SCREW		2
7	A01376201	HINGE FLIP MULLION MD		1
8	A01321401	MULLION FLAP MD		1
NI	A01371901	SPRING FLIP MULLION		1
9	811988556	GASKET FC MD90		2
10	N.P.N	NOT USED IN THIS MODEL		1
11	N.P.N	NOT USED IN THIS MODEL		1
12	808337901	SCREW		2
13	A01046504	BEARING AUTO CLOSER LH		1
	A01046502	BEARING AUTO CLOSER RH		1
14	A17859704	DOOR SPARE FZR L+R WQE6060BB		1
15	811988585	GASKET FZR RH/LH		2
16	A17859704	DOOR SPARE FZR L+R WQE6060BB		1
17	A00807802	TRAY EGG 80W		1
18	N.P.N.	NOT USED IN THIS MODEL		
19	A00804207	BIN DOOR FLEX 80 1-HOTFOIL		3
20	A05205803	BIN DOOR FCSHAL MD90HOTFO PE		2
*21	A00806104	BIN DOOR DAIRY LID 80 EL-ART		1
*22	A00806002	BIN DOOR DAIRY BODY TF80 EL		1
23	A00715005	BIN DOOR FINGER MD90 ASSY		2
	A00715005	BIN DOOR FINGER WH (PART of 23)		
24	A17859706	DOOR KIT FC LH + RH (2 FRIDGE DOORS)		1
25	811988556	GASKET FC MD90		1
26	REFER ITEM 2	HANDLE ASSY MD KIT (INC. ITEM'S 2, 26 & 27)		1
27	REFER ITEM 2	PEDESTAL INCLUDED IN ITEM 2		
28	A01069002	BEARING HINGE TOP CLOSED		1
29	N.P.N	NOT USED IN THIS MODEL		
30	1457228	SWITCH LIMIT PLUNGER		1
31	808212301	LEVER DISPENSER WH		1
32	REFER ITEM 2	HANDLE ASSY MD KIT (INC. ITEM'S 2, 26 & 27)		1
NI	1458193	BADGE WESTINGHOUSE		1

*NOTE: Items 21 & 22 are also available as P/N: A00803106, BIN DOOR LOCKABLE COMPLETE ASSY.

MODEL: WQE6000BB & WQE6060BB

INTERNAL FRIDGE SECTION

Ex 8406

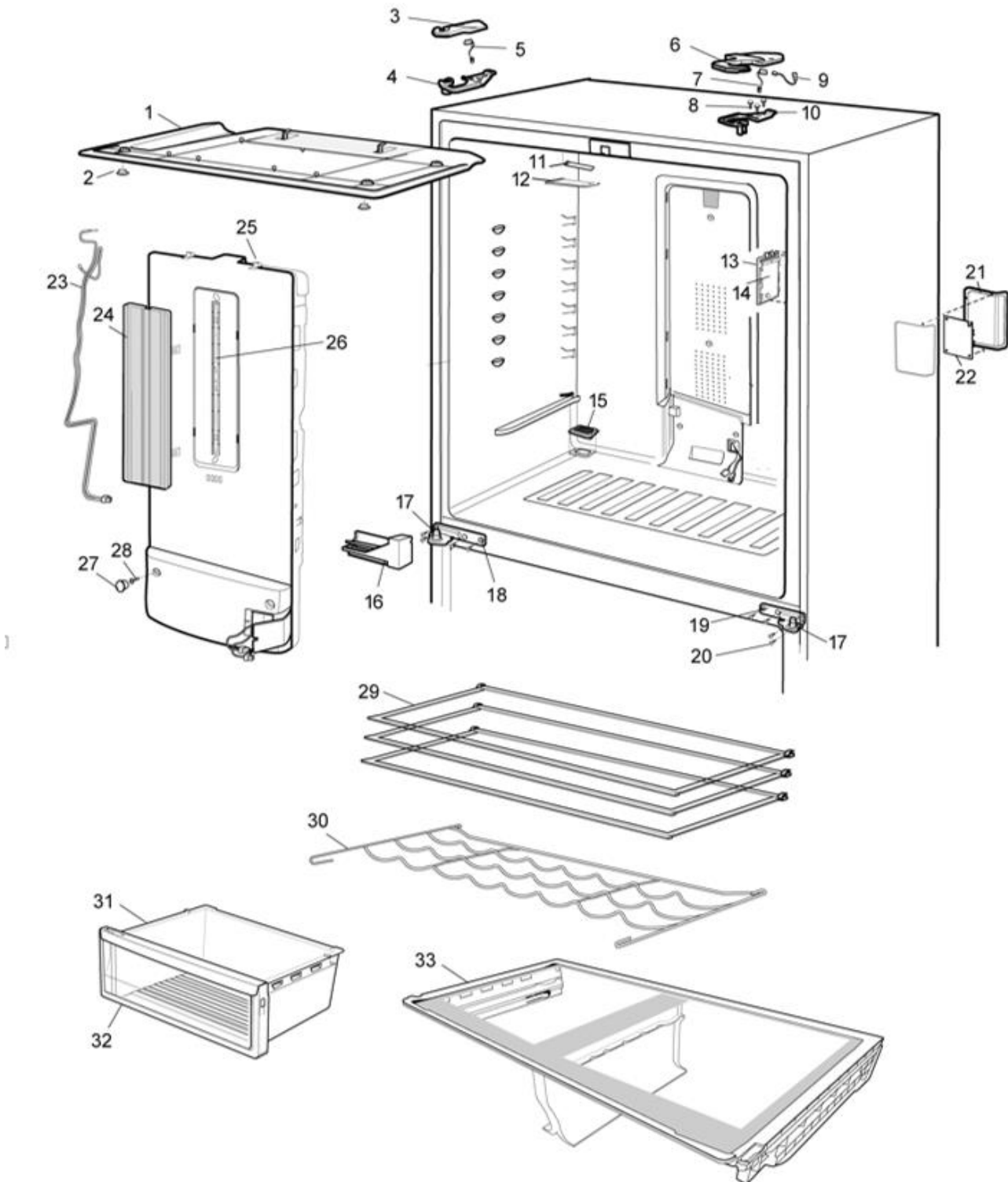

Item	Part N°	Description	8406	WQE6000	WQE6060
1	A06378103	COVER WATER TANK ASSY			1
2	A02609301	COVER SCREW SNAPPED		2	2
3	A01826707	COVER TOP HINGE IW LH DG		1	1
4	A00354402	HINGE TOP LEFT		1	1
5	242326001	SWITCH DOOR REED		1	1
6	A01145507	COVER TOP HINGE IW RH DG		1	1
7	242326001	SWITCH DOOR REED		1	1
8	811949401	SCREW TRILOB M5X16		6	6
9	809128701	SENSOR HUMIDITY MD		1	1
10	A00354401	HINGE TOP RIGHT		1	1
11	242196207	PCB 3LEDS CLUSTER		1	1
12	A08828001	LENS 3 LEDS CLUSTER		1	1
*13	A01075002	DISPLAY, USER INTERFACE		1	
*13	A00984706	DISPLAY, USER INTERFACE			1
*14	A01084002	PCB, USER INTERFACE		1	
*14	A02282404	PCB, USER INTERFACE			1
15	A00896401	COVER GRID AIR RETURN BF		1	1
16	811549301	BAFFLE MOTOR ASSY FBZA-1750-3D		1	1
17	A01604801	CENTRE HINGE PIN DOOR		2	2
18	A01604503	CENTRE HINGE BASE ASSY		2	2
19	807826801	SCREW TRILOB M6X18		4	4
20	A01846302	SCREW TRILOBULAR M4X12		4	4
21	A01277301	COVER REAR PCB		1	1
22	A01028915	ERF2003 15W CYAN_S_INT_MD_		1	
22	A01028829	ERF2003 15W RUBY_S_MD_I&W			1
23	A05257410	HARNESS-ASSY M/FLOW BF WEST		1	1
24	A01098402	LENS COVER BLUE ASSY		1	1
25	A00748905	MULTIFLOW ASSY MD90 WH		1	1
26	807717401	PCB LED G_SSLB MULTIFLOW		1	1
27	A00906801	COVER SCREW MULTIFLOW LH		1	1
	A00906802	COVER SCREW MULTIFLOW RH		1	1
28	811949503	SCREW TRUSS 4.2X13		4	4
29	A05196001	SHELF FC MD90W		3	3
30	A06335201	BOTTLE RACK 90		1	1
31	A05656501	DRAWER CRISPER BODY MD90		2	2
32	A00793612	DRAWER FRONT MD90 WH ASSY		2	2
33	A05657501	COVER CRISPER ASSY MD90 WH		1	1
*NOTE: ALSO AVAILABLE AS AN ASSEMBLY: WQE6000BB - A04066702; and WQE 6060BB - A04066803					

MODEL: WQE6000BB & WQE6060BB
SYSTEM FREEZER

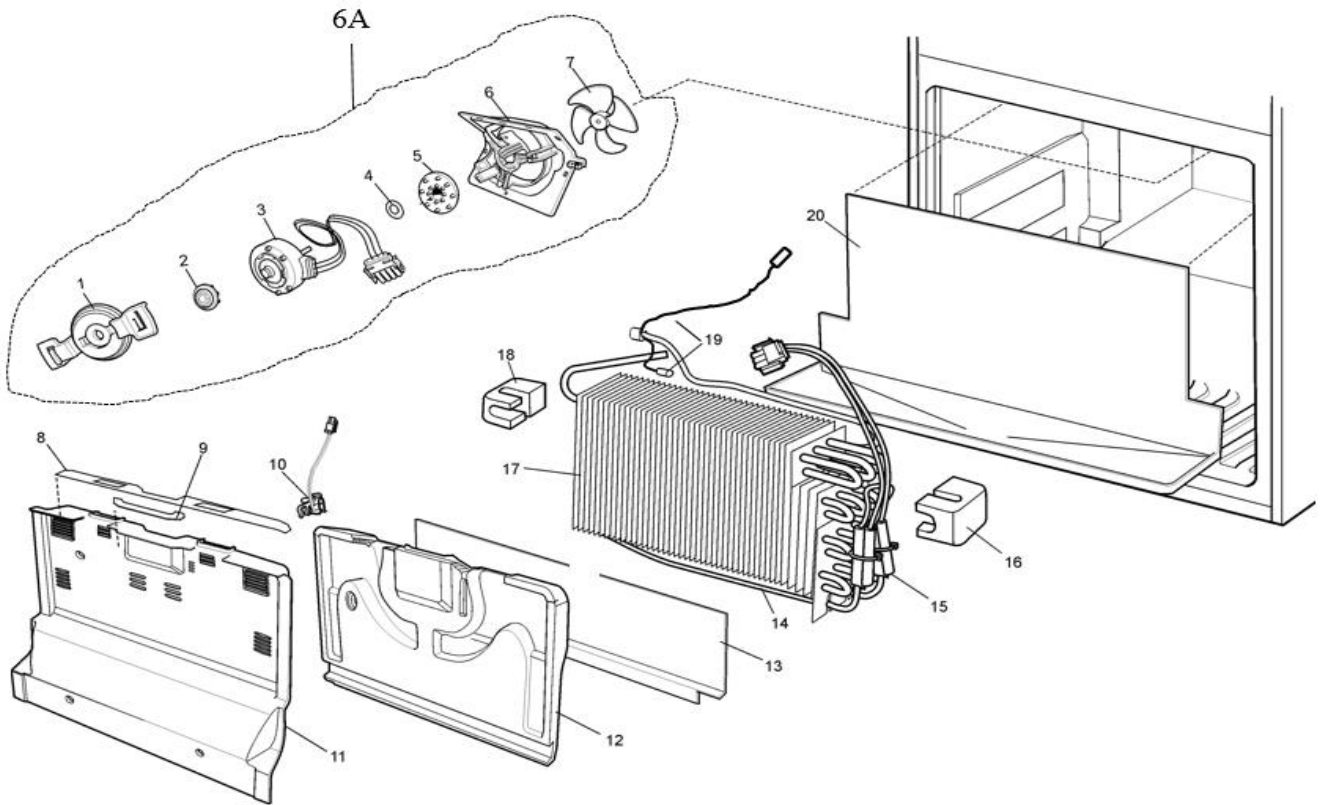

ITEM	PART Nº	DESCRIPTION 8409	QTY
1	A02113401	BRACKET SHROUD FAN	1
2	1446048	GROMMET, FAN MOUNTING	1
3	809069203	MOTOR FAN DC 3W	1
4	1451297	WASHER SLINGER NYLON	1
5	A02113401	GROMMET, FAN MOUNTING	1
6	811975001	SHROUD FAN BF	1
6A	811975403	SHROUD FAN ASSY. COMPLETE ASSY	1
7	811699602	BLADE FAN	1
8	REFER ITEM 11	SEAL (PART of 11)	
9	REFER ITEM 11	SEAL (PART of 11)	
10	811980402	CLAMP NTC EVAPORATOR	1
11	A05993101	COVER EVAPORATOR ASSY MD90 (INC. 8, 9 & 13)	1
12	A05400001	EPS EVAPORATOR MD 90	1
13	A04318603	SEAL FOAM EPDM	1
14	A01058217	HEATER RAD DEF R600 240V MD90W	1
15	N.P.N.	THERMAL FUSE (PART OF HEATER ASSY)	1
16	A03637801	SPACER 3 TURN HEATER	1
17	A04063204	EVAPORATOR FF MD90	1
18	A03637801	SPACER 3 TURN HEATER	1
19	A05206102	SENSOR HARNESS-ASSY DEFROST	1
20	A05399701	TRAY EVAP DRAIN MD90W	1
NI	811909402	MASTIC (SUNDRY)	1
NI	A02249601	SUPPORT EVAPORATOR BF	2

MODEL: WQE600BB & WQE6060BB

INTERNAL FREEZER SECTION

Ex8458

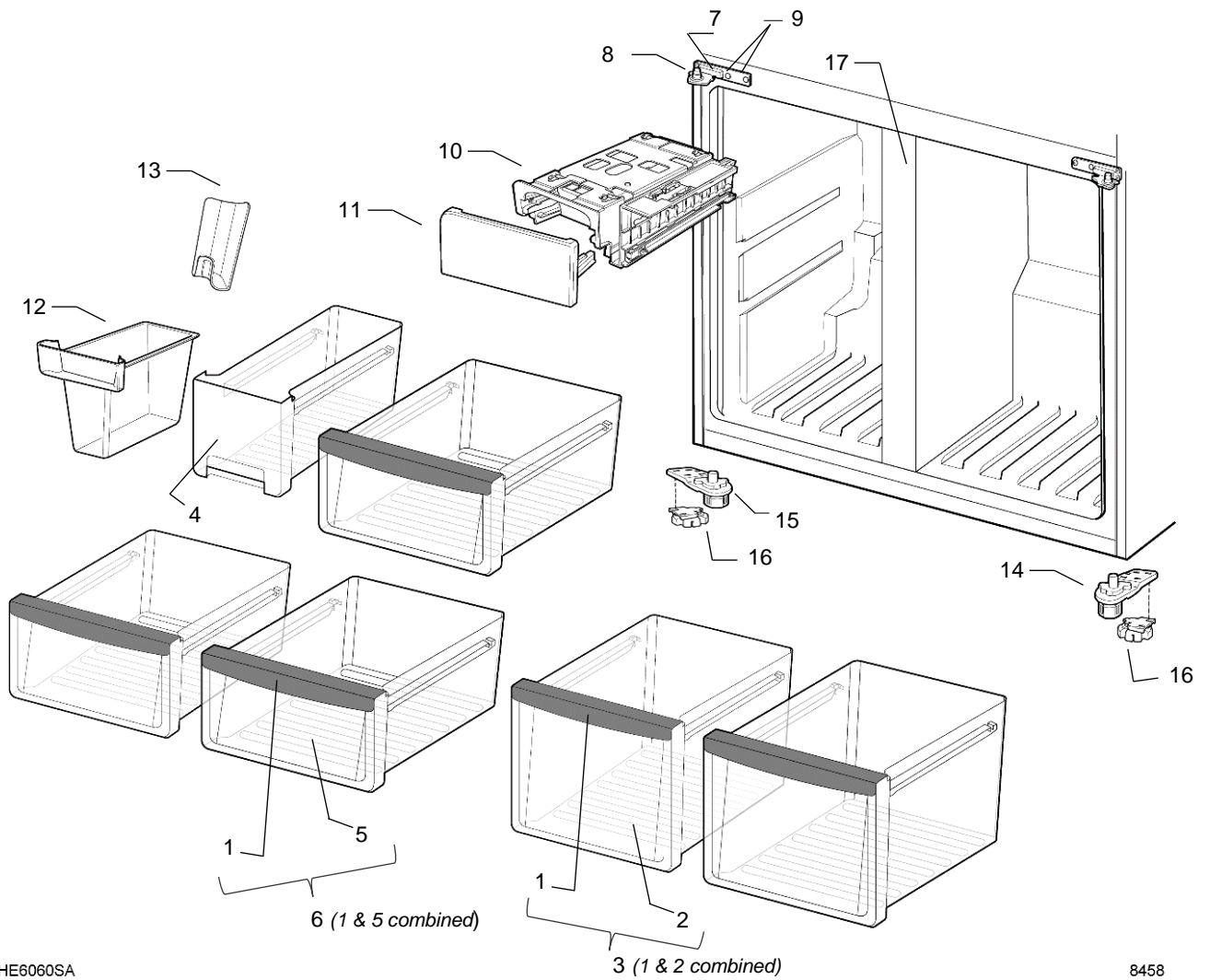

WHE6060SA

8458

ITEM	PART N°	DESCRIPTION 8458	WQE6000BB	WQE6060BB
1	A12471701	DRAWER FZR HANDLE MDQ90	5	5
2	A12471801	DRAWER FZR LOWER BODY MDQ90	2	2
3	A12471901	DRAWER FZR LOWER MDQ90 ASY	2	2
4	A12472001	DRAWER FZR SMALL MD90Q ART	1	1
5	A12472201	DRAWER FZR MID BODY MDQ90	3	3
6	A12472301	DRAWER FZR MID MDQ90 ASSY	3	3
7	A01604503	CENTRE HINGE BASE ASSY	2	2
8	A01604801	CENTRE HINGE PIN SWING DOOR	2	2
9	807826801	SCREW TRILOB M6X18	4	4
10	A01959301	ICE MAKER BRACKET	1	1
11	A01959503	ICE MAKER COVER		1
12	A00957204	ICE BIN AIM BF ELUX		1
13	1451633	ICE SCOOP		1
14	A01819905	HINGE BASE ASSY RIGHT WITH ADJ	1	1
15	A01819906	HINGE BASE ASSY LEFT WITH ADJ	1	1
16	A01977002	ROLLER FIXED FOOT ASSY	2	2
	A01819101	FOOT BASE THREAD (PART of 16)	2	2
	A01808801	SHAFT AXIS ROLLER (PART of 16)	2	2
	A01819203	ROLLER FOOT (PART of 16)	2	2
	A01819302	FOOT LEVER (PART of 16)	2	2
17	A12471201	FREEZER DIVIDER ASSY	1	1
	A12471001	FREEZER DIVIDER LH (PART of 17)	1	1
	A12471101	FREEZER DIVIDER RH (PART of 17)	1	1
	A12469601	RUBBER SEAL CONDIUT DIVIDER RE (PART of 16)	1	1
	A12470901	EPS FREEZER DIVIDER (PART of 16)	1	1
NI	A12469501	SEAL CONDIUT DIVIDER FRONT	1	1
NI	A12483401	PLATE FRONT DIVIDER MDQ90 ASSY	1	1
NI	811956701	T&S ICE MAKER ASSY WHITE	1	
NI	811956601	BIN ICE PACIFIC CLEAR	1	

MODEL: WQE6060BB

ICE AND WATER COMPONENTS

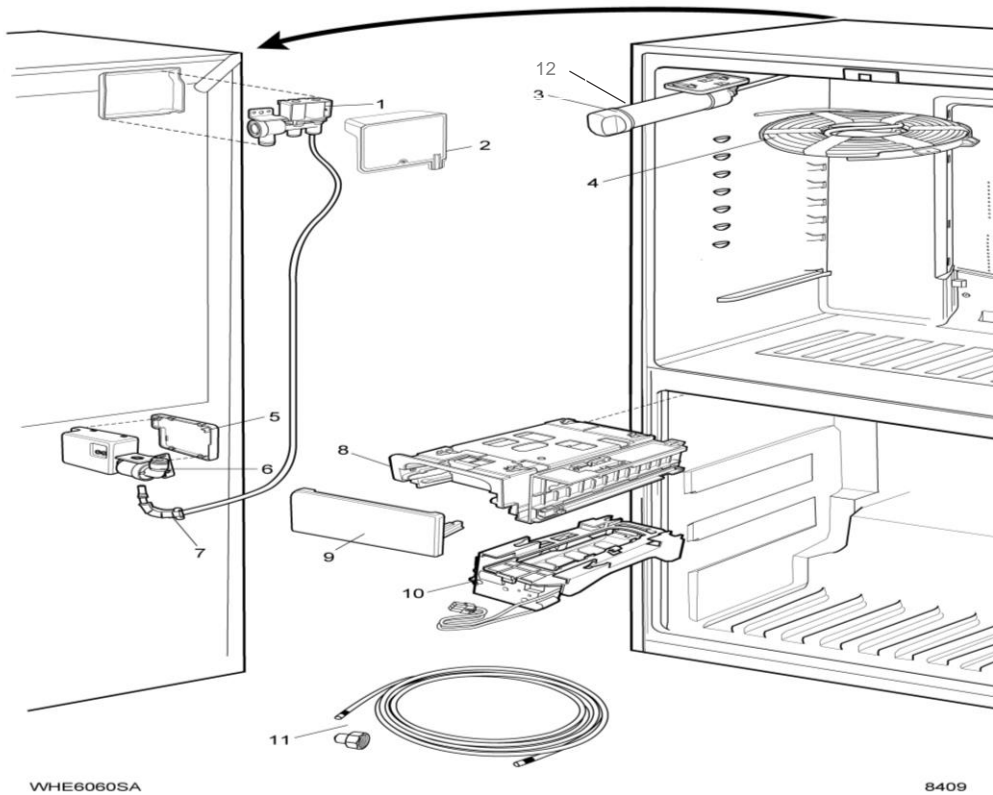

ITEM	PART N°	PART DESCRIPTION 8409	WQE6060
1	A02477401	VALVE INLET 2-WAY	1
2	A01983802	COVER VALVE REAR PANEL	1
3	807946705	FILTER ASSEMBLY (PINOT)	1
4	A01980902	TANK WATER COIL	1
*5	A02904502	COVER LID SINGLE VALVE	1
*6	A02607201	SINGLE VALVE	1
7	A03885402	TUBE EXTRA	1
8	A01959301	ICE MAKER BRACKET	1
9	A01959503	ICE MAKER COVER	1
10	890141991	ICE MAKER BF/MD	1
11	A03159801	ICE&WATER INSTALLATION KIT	1
12	807931803	HOUSING CONNECTOR FILTER (includes Beige hose to valve)	1
*NOTE: Items 5 & 6 are also available as Assy: PN A05541601, SINGLE VALVE ASSEMBLY.			

BLOCK DIAGRAM / WIRING DIAGRAM

WQE6000BB-D 925060254

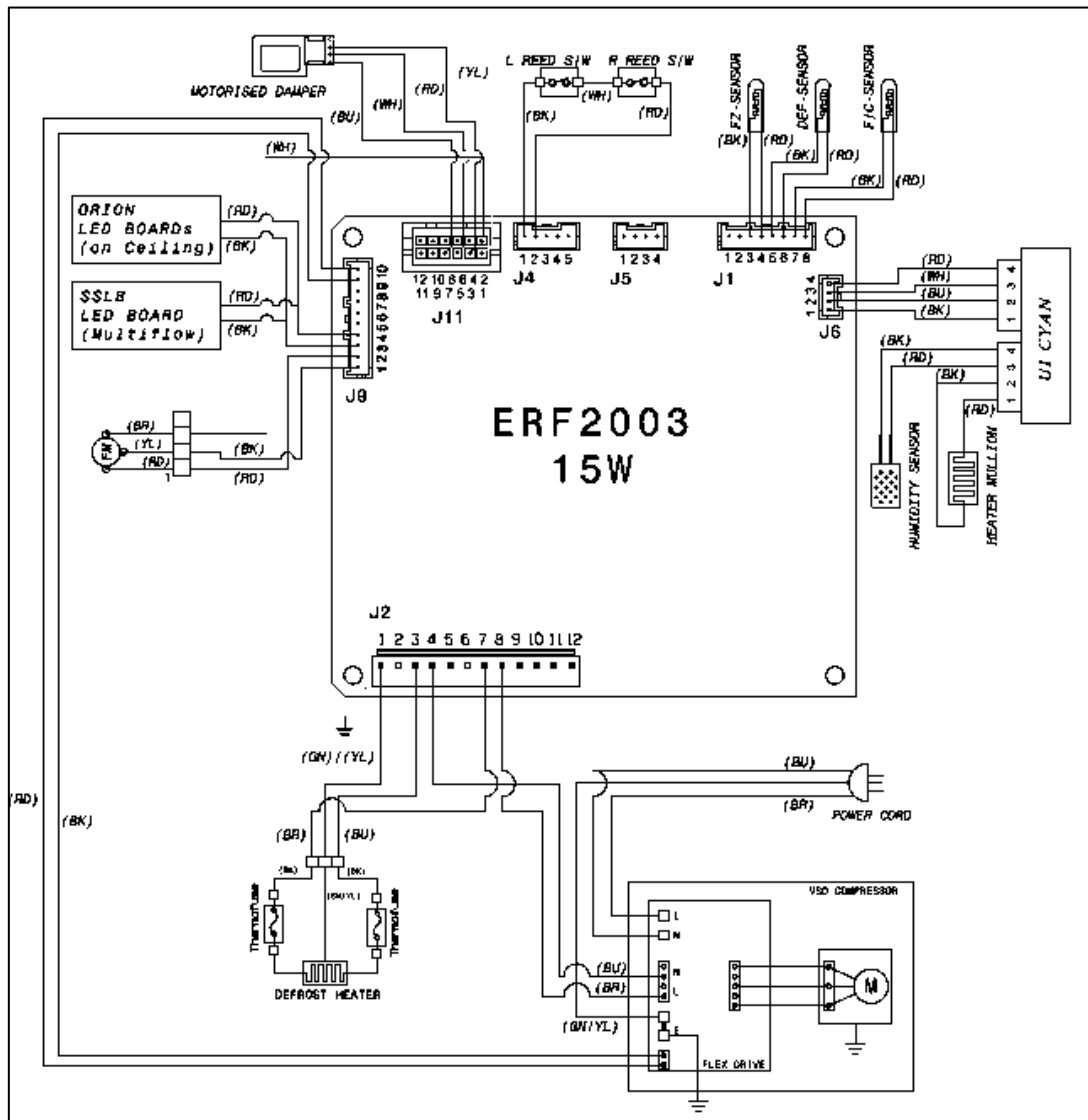

WQE6060BB-D 925060255

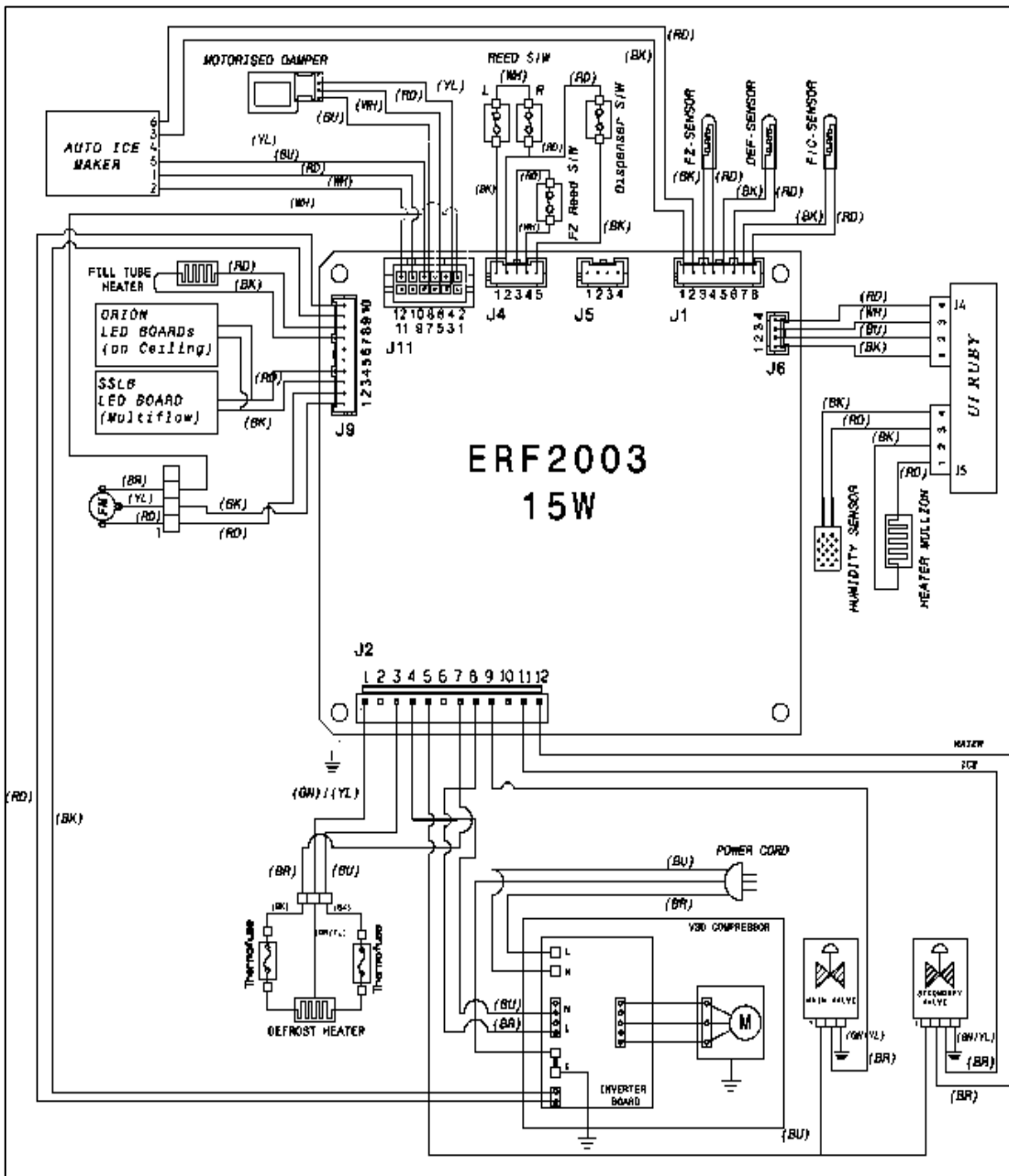

WARNING
IT IS ILLEGAL FOR PERSONS OTHER THAN LICENSED ELECTRICAL MECHANICS OR PERSONS AUTHORISED BY LEGISLATION TO WORK ON THE FIXED WIRING OF ANY ELECTRICAL INSTALLATION. PENALTIES FOR CONVICTION ARE SEVERE.

IMPORTANT SAFETY NOTICE
This diagram has been prepared for use by electrically qualified service technicians. Electrolux cannot be held responsible for the interpretation of its service publications nor for any injury or damage that may occur in connection with their use.

Publication Version Control Chart		
Issue Number	Reason	Date
1	Original Document	29-05-2019
2	Amends fridge door shallow bin PN & Desc.	27-08-2019