

PARTS MANUAL

Top Load Washing Machine

HWT80MW1 HA AA

Product Code
61387-A

AU NZ

Haier

CONTENTS

INTRODUCTION	2
TOP CONSOLE COMPONENTS	3
CABINET COMPONENTS	5
BOWLS & MOTOR COMPONENTS	7

INTRODUCTION

BRAND	VOLTAGE	MODEL		PRODUCT CODE
Fisher & Paykel	220-240 50Hz	HWT80MW1	HA AA	61387-A

MODELS

The models covered by this manual are listed on the front cover. The information detailed in this manual is subject to change without notice. The latest version is indicated by the reprint date and replaces any earlier editions.

KIT PARTS

Kit components are shown in italics. Where a part number is shown against the descriptions for these kit components, they are also available as separate items. In addition, some parts may be supplied with these kits that are not available as separate items, and are therefore either not listed, or a part number is not shown against the part description in this manual.

PARTS LIST KEY

ITALICS	Kit components or parts included are shown in italics. Refer to above notes: Kit Parts.
NI	As a part reference, indicates the part is not illustrated on the diagram.
NOT USED	As a part number, indicates the diagram part reference is not used in this manual.
NS	As a part number, indicates the part is not servicable.

NZ

Fisher & Paykel Appliances Ltd
78 Springs Road, East Tamaki
Manukau 2013
PO Box 58-546 Botany
Manukau 2163
New Zealand

tel: 09 273 0600
fax: 09 273 0656
e-mail: nz.customercare@fisherpaykel.com

AU

Fisher & Paykel Customer Services Pty Ltd
PO Box 798, Cleveland, QLD 4163
A.C.N. 003 3335 171
19 Enterprise Street
Cleveland, QLD 4163
Australia

tel: 07 3826 9100
fax: 07 3826 9164
e-mail: aus.customercare@fisherpaykel.com

TOP CONSOLE COMPONENTS

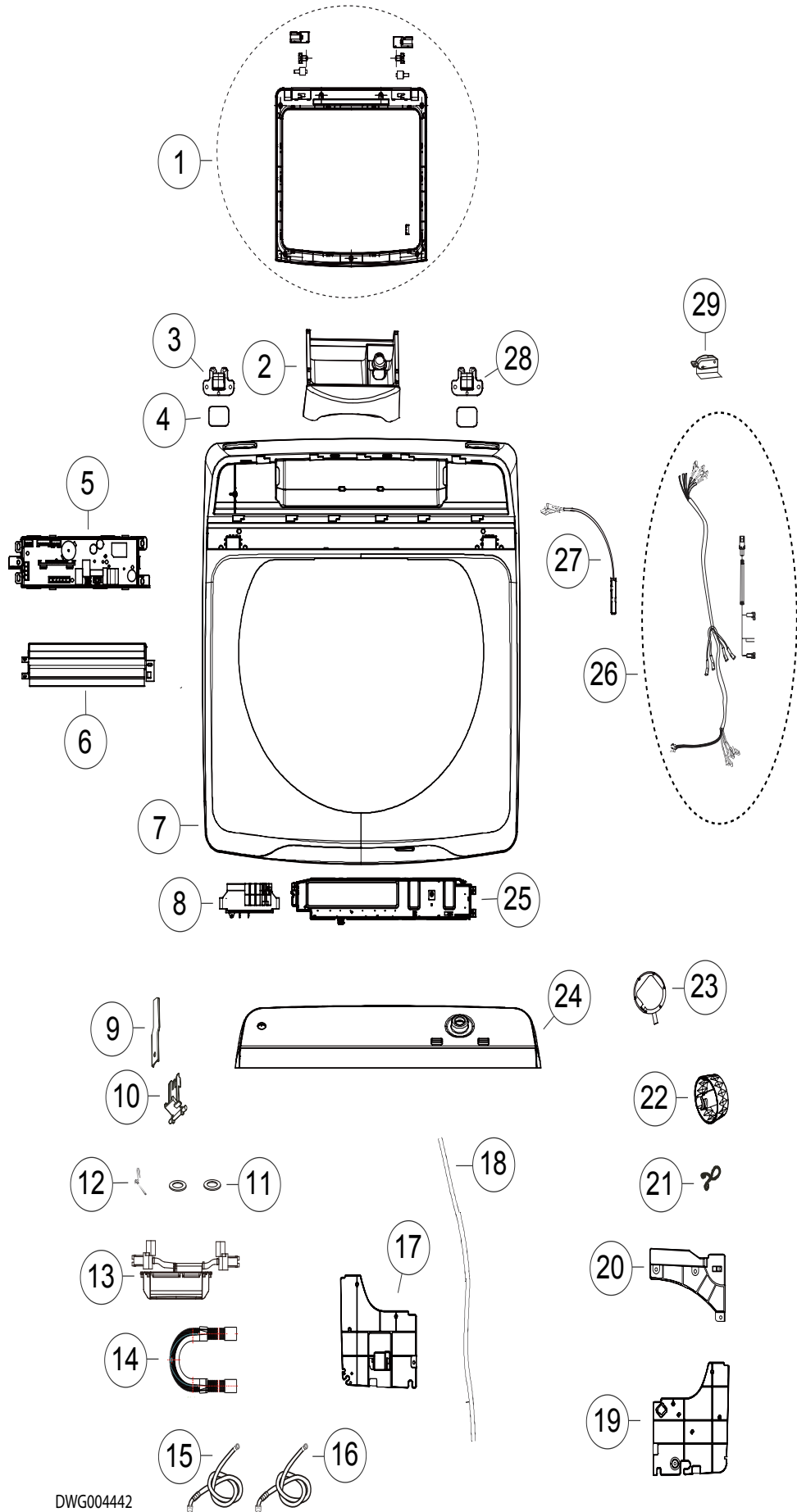

DWG004442

DWG004442

TOP CONSOLE COMPONENTS

REFERENCE	PART NUMBER	PART DESCRIPTION
1	H0030813016D	LID ASSY
2	H0030814364	DETERGENT CONTAINER
3	H0030101738	LID HINGE RH
4	H0030300737	GASKET SEALING
5	H0031800083D	COMPUTER BOARD
6	H0030102075	PCB COVER
7	H0030208147A	TOP DECK
8	H0034001068A	DOOR LOCK
9	H0030206513	CONTROL ROD
10	H0030206511	BRACKET OOB ASSY
11	H00330103014	GASKET WATER INLET
12	H00330603004	SPRING OUT OF BALANCE
13	H0030814201	INLET VALVE ASSY
14	H0030806881A	HOSE DRAIN
15	420375P	HOSE INLET COLD
16	H0030802835	HOSE INLET HOT
17	H0030208156	SPLASH SHIELD LHF
18	H0030201143K	PRESSTUBE 8MM X 740 MM
19	H0030208155	SPLASH SHIELD RHF
20	H0030208113	SPLASH SHIELD RH BACK
21	H00330602003A	CLAMP PRESSURE TUBE HOSE
22	H0030209305	KNOB
23	H0034001009B	PRESSURE SWITCH
24	H0030813085C	CONTROL PANEL
25	H0031800113A	DISPLAY PANEL
26	H0030400719C	WIRING HARNESS
27	H0034000405H	REED SWITCH
28	H0030101737	HINGE BASE LH
29	H00330503062	SWITCH OUT OF BALANCE
NI	H0030202758	COVER LEFT TOP DECK SCREW
NI	H0030202759	COVER RIGHT TOP DECK SCREW

CABINET COMPONENTS

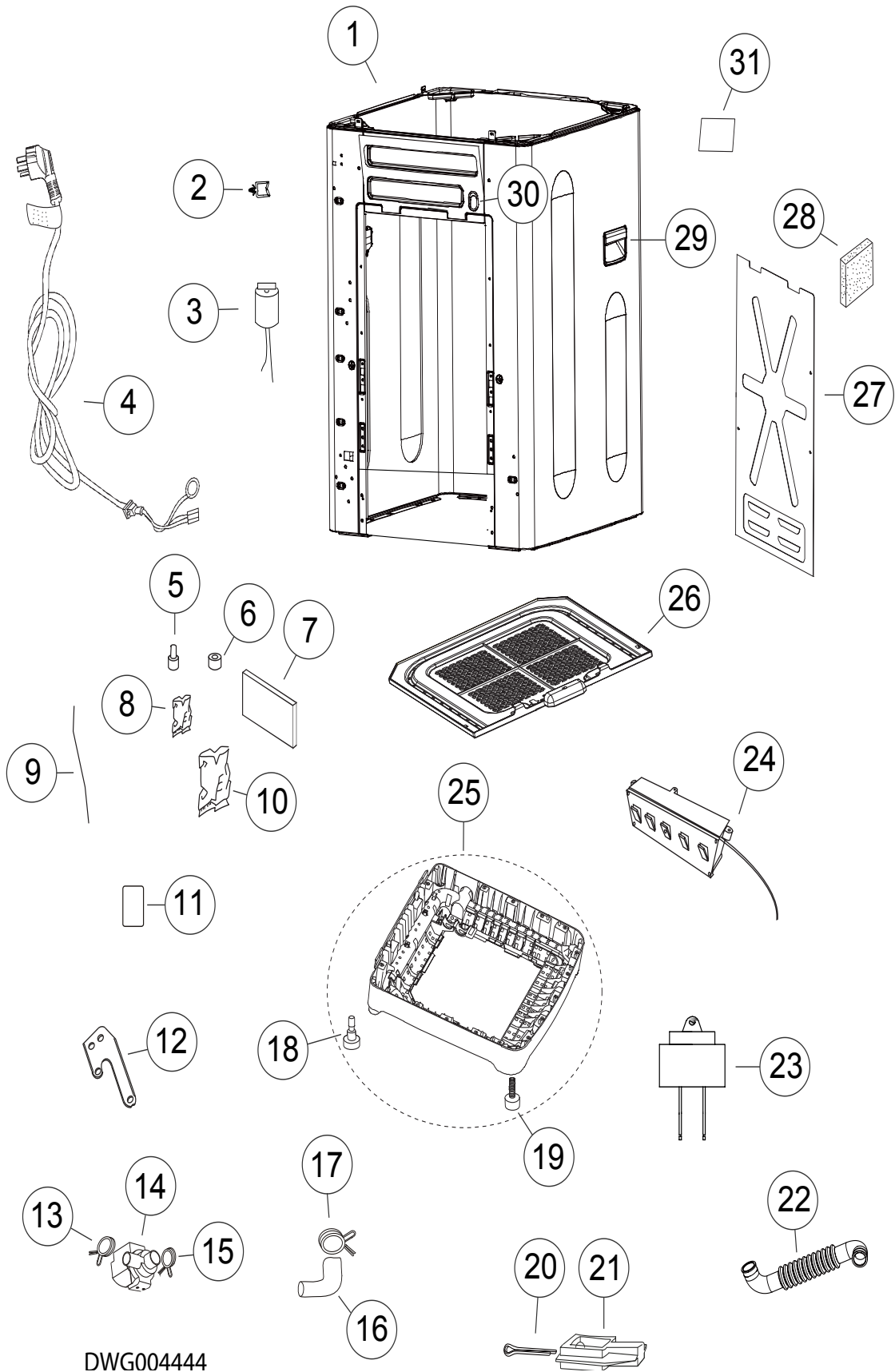

DWG004444

DWG 004444

CABINET COMPONENTS

REFERENCE	PART NUMBER	PART DESCRIPTION
1	H0030813218A	CABINET
2	H0030201442A	HARNESS WIRE HOLDER
3	H0034000883E	EMI FILTER
4	H0030400126A	MAINS CABLE
5	H0030205313	BUSH B
6	H0034000872	RING MAGNET
7	H00330104012A	GASKET BUFFER
8	H0030508588H	BAG PROTECTION
9	H00340821013	TIE TWIST
10	H0030508588G	SAFEGUARD BAG
11	H0030204065	PAD FELT
12	H00330302024	BRACKET DRAIN PUMP
13	H0030100007	CLAMP DRAIN INNER TUB
14	H0034000110D	PUMP DRAIN
15	H0030100006	CLAMP DRAIN HOSE
16	H0030300038A	HOSE DRAIN TUB PUMP
17	H0030101020	CLAMP DRAIN HOSE INNER
18	H0030300687	FOOT FIXED
19	H0030811477	FOOT ADJUSTABLE
20	H0030600184	ROD CONNECTING
21	H0030201240	ARM DRAIN MOTOR
22	H0030300855	HOSE PUMP TO CABINET
23	H0034000871A	REACTOR
24	H0031800098C	MOTOR CONTROLLER
25	H0030812027C	BASE INCL FEET
26	H0030209144	BASE PLATE
27	H0030100432	PANEL BACK COVER
28	H00330104007C	CABINET BUFFER
29	H0030207316E	HANDLE CABINET
30	H0030208194A	HOOK
31	H0030204065	PAD FELT

BOWLS & MOTOR COMPONENTS

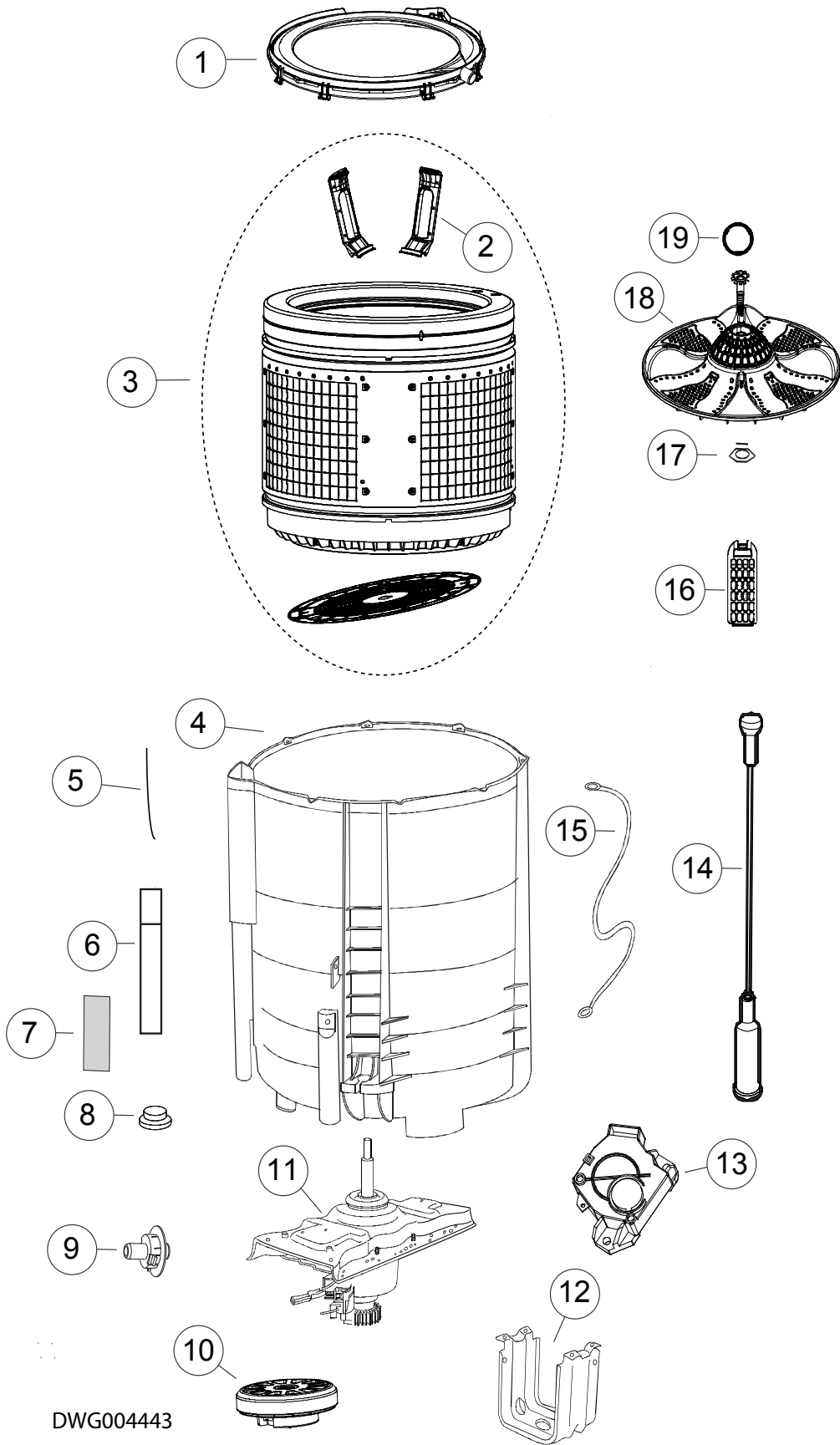

DWG004443

BOWLS & MOTOR COMPONENTS

REFERENCE	PART NUMBER	PART DESCRIPTION
1	H0030205815A	NECK RING
2	H0030209642	FILTER COVER
3	H0030813912B	INNER TUB
4	H0030205579	TUB OUTER
5	H00221120021000	BINDING WIRE
6	H0030209356	OVERFLOW PIPE
7	H0030204065	PAD FELT
8	H00330101020	COVER AIR BELL
9	H0030200631	BUSH DRAIN HOSE
10	H0034001033	MOTOR
11	H0030801895	TRANSMISSION
12	H0030101030	SHIELD
13	H0034000764	ACTUATOR BRAKE
14	H0030805552A	SUSPENSION ROD WHITE
15	H0030400735	EARTH WIRE
16	H0030811660	LINT FILTER
17	H00330303005	GASKET PULSATOR
18	H0030207871	PULSATOR
19	H0030202331D	PULSATOR COVER

www.fisherpaykel.com

Copyright © Fisher & Paykel 2017. All rights reserved.
The product specifications in this manual apply to the specific model described at the date of issue. Under our policy of continuous product improvement, these specifications may change at any time. Only use this manual if the product code on the front matches the product code on the serial label of the product.

AU NZ

PRODUCT CODE: 61387-A 05.17