



INSTALLATION INSTRUCTION



Before performing any steps, all ammunition must be removed from the firearms. Remove the magazine from the firearm. Fully pull the slide or bolt group to eject the round from the chamber. Visually inspect through the ejection port to verify that no ammunition is in the chamber. Always keep the muzzle pointed in a safe direction. Without performing this safety precaution may cause serious injury or death to personals. MECHFORCE is not liable for any damage or injury sustained through improper installation.

- 1 Constrain the firearm on a workbench clamp with a barrel jaw.
- 2 Remove the existing muzzle brake from the firearm if equipped.
- 3 Choose the correct crush washer to use. There are four crush washers supplied with the package, each with different thickness that will give four different thread-starting angles (the muzzle brake's orientation angle when fully threaded in with the crush washer untorqued) each offset 90 degrees.
- 4 Try putting each crush washer on with the muzzle brake full threaded in but untorqued. Use the one that will give the results matching or close with the image below, which the top ports on the muzzle brake pointing 9 o'clock position.
- 5 Clean the barrel thread and apply thread locking compound. (The thread locking compound is not included in this package.)

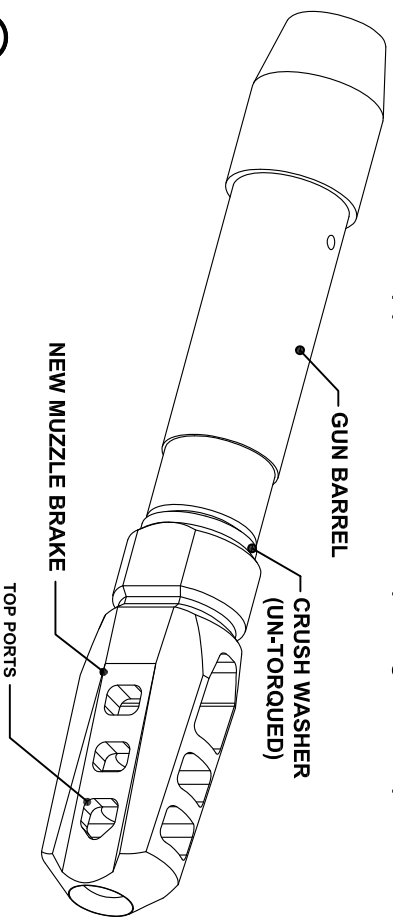

VISIT US AT WWW.MECHFORCE-USA.COM
FOR OTHER EXCITING PRODUCTS



- 6 Slide the chosen Crush Washer over the muzzle threads with the concave side facing the new muzzle brake, and the convex side is facing the receiver.

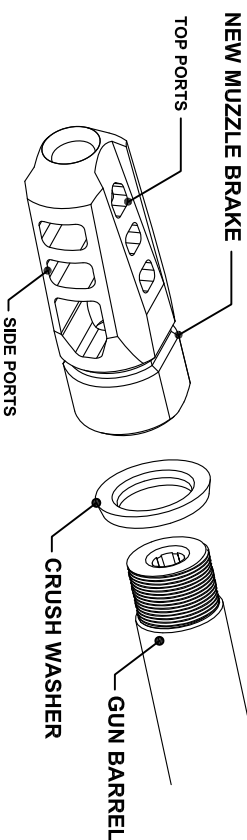

- 7 Screw the new muzzle brake onto the barrel thread snug tight then use a wrench to torque the muzzle brake clockwise to about 90° rotation (20 - 30 ft-lbs).
- 8 Fine tune the orientation of the muzzle brake until the top ports are at the 12 o'clock position perfectly and the side ports are horizontal.
- 9 Remove the firearm from the workbench. The installation is complete.

NOTE:

1. Only one crush washer shall be used. Do not use more than one crush washer per barrel thread. Do not use the crush washer in combination of other parts (shims, jam nut).
2. Crush washer shall not be reused after crushed (permanently deformed).

PRODUCT SPECIFICATION

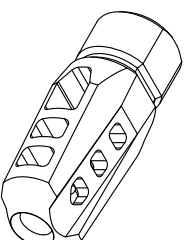

Product Name: Enforcer - 6.5 Creedmoor
 Part Number: 10030
 Material: Proprietary Heat Treated Millspec Steel
 Finish: Black Nitride
 Dimension: L 2.642" x W 1.053" x H 0.828"
 Weight: 4.2 OZ
 Thread: 5/8-24 TPI R/H
 Made in USA

VISIT US AT WWW.MECHFORCE-USA.COM
FOR OTHER EXCITING PRODUCTS