

**EN**  
2021

# **SUPER73**



OWNER'S HANDBOOK  
ASSEMBLY & MAINTENANCE

**Super73 R/RX**

# WELCOME!

Please read this owner's handbook carefully before using your Super73 in order to become thoroughly familiar with the correct operation of your bike's controls, it's features, capabilities, and limitations. This handbook includes safe riding tips, but does not contain any of the techniques and skills necessary to ride an electric bicycle safely.

**Join the Supersquad community of riders wherever you are!**

This is just the beginning of your adventure with us! We look forward to hearing about your experience and seeing you online on our social networks:

 [Instagram.com/Super73](https://www.instagram.com/Super73) and [Instagram.com/Super73eu](https://www.instagram.com/Super73eu)

 [Youtube.com/c/Super73](https://www.youtube.com/c/Super73)

 [Facebook.com/groups/Super73owners/](https://www.facebook.com/groups/Super73owners/)

Tag us! @Super73 @super73eu #Super73 #super73eu

## CONTACT SUPER73

### North America:

SUPER73, Inc.  
16591 Noyes Ave  
Irvine, California 92606  
United States  
+1 (814) 747-9072

[customercare@super73.com](mailto:customercare@super73.com)  
[www.super73.com](http://www.super73.com)

### Europe:

SUPER73 B.V.  
Industrieweg 61-63  
1115 AD Duivendrecht,  
The Netherlands  
0031 (0)20 30 800 73

[customercare-eu@super73.com](mailto:customercare-eu@super73.com)  
[eu.super73.com](http://eu.super73.com)

---

This handbook was drafted in the English language (Original instructions) and may have been translated into other languages as applicable (translation of Original instructions).

This handbook contains information on the Super73 electric bikes. Always store this Owner's Manual with the Super73 and refer to it for information whenever necessary. The information contained in this publication is based on the latest information available at the time of printing.

Please note all instructions and notices are subject to change and updates without notice. Please visit [www.super73.com](http://www.super73.com) for periodic technical updates.  
Feedback: [customercare@super73.com](mailto:customercare@super73.com)

This is not to be reproduced wholly or in part without the written permission of Super73. ©Copyright 2021 Super73, Inc. , V.03. Updated 11/2021.





# TABLE OF CONTENTS

Contact Information .....	2
General Information .....	5
Diagram of R-Series .....	6
Legal Information .....	8
Intended use .....	8
Unpacking Instructions .....	9
Assembly Instructions .....	10
Registration .....	13
Pre-ride safety check .....	14
Operating the bike .....	15
Suspension Adjustment Guide .....	18
Super73 App .....	21
General Warnings .....	22
Safety .....	23
Maintenance Schedule .....	27
Maintenance and Components .....	28
Warranty .....	32



## + **MISSION STATEMENT** +

Super73 exists to create adventure and **community**. We strive to bolster adventurous exploration through **innovation**, create positive and forward-thinking experiences with **integrity**, and cultivate enthusiastic support and vision for the community.



# GENERAL INFORMATION

Please note the following symbols:



## **WARNING!**

Warnings, precautions, and potential risks associated with the use of your Super73.



## **Danger!**

Possible dangers for your life and health if respective calls to action are ignored.



## **Tip!**

Recommendation! Meaningful additional information.

Please perform a safety check before each use, as described on in the “Pre-ride Safety Check” section of this handbook.

If you feel uncertain about proper configuration after assembling your Super73 according to the provided assembly instructions, please contact your specialized retailer or Super73 directly.



**If any of the instructions are beyond your skill set, we recommend taking your Super73 to a certified E-Bike specialist or professional cycle mechanic for assembly.**



**This owner’s handbook includes assembly and maintenance work which may need to be done at frequent intervals to maintain an operational and safe super73. Never perform work on your Super73 beyond instructions in this handbook. This handbook is not intended as a comprehensive use, service, repair or maintenance handbook. Do NOT ride your Super73 if it has been assembled incorrectly. Maintenance beyond what the owner’s handbook instructs is to be handled by an E-Bike specialist or professional cycle mechanic. Riding an incorrectly assembled bike can put your own safety at risk as well as others.**

## **EUROPE - PREAMBULE**

Super73 electric bikes purchased in Europe and sold for use in Europe have been tested, certified and are conform to security requirements of EPAC (Electric Power Assisted Cycle) according to EN 15194, have a maximum speed of 25 km/h and a 250 Watt motor power output. Principles of operation of a pedelec:

Your power-assisted bike is “assisted”. This means that, according to the legislation, you have to pedal continuously for assistance. The assist is active only during the pedaling movement. The assistance of your bike is cut beyond 25km/h as required by French and European regulations.

# DIAGRAM OF THE SUPER73 R-SERIES

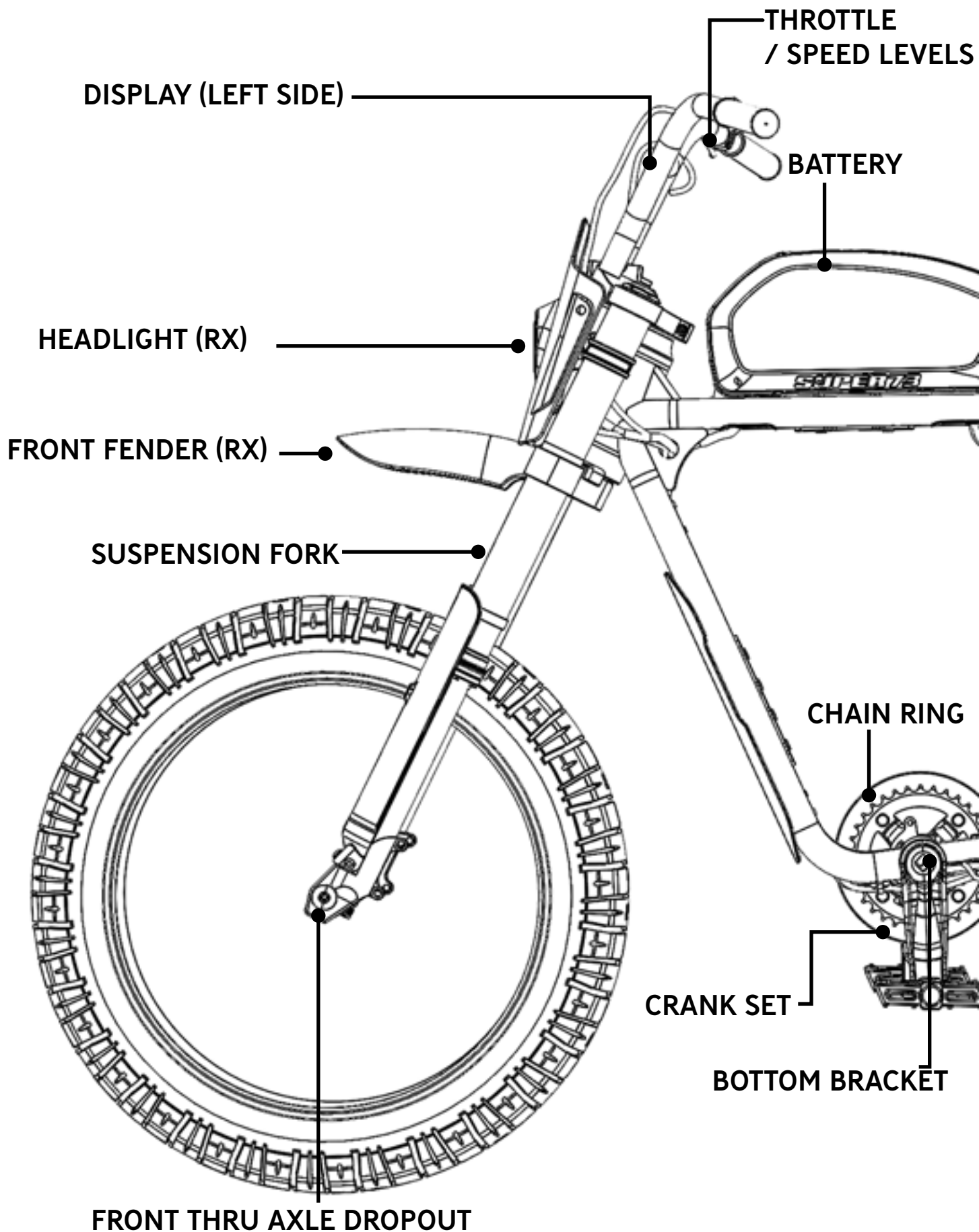

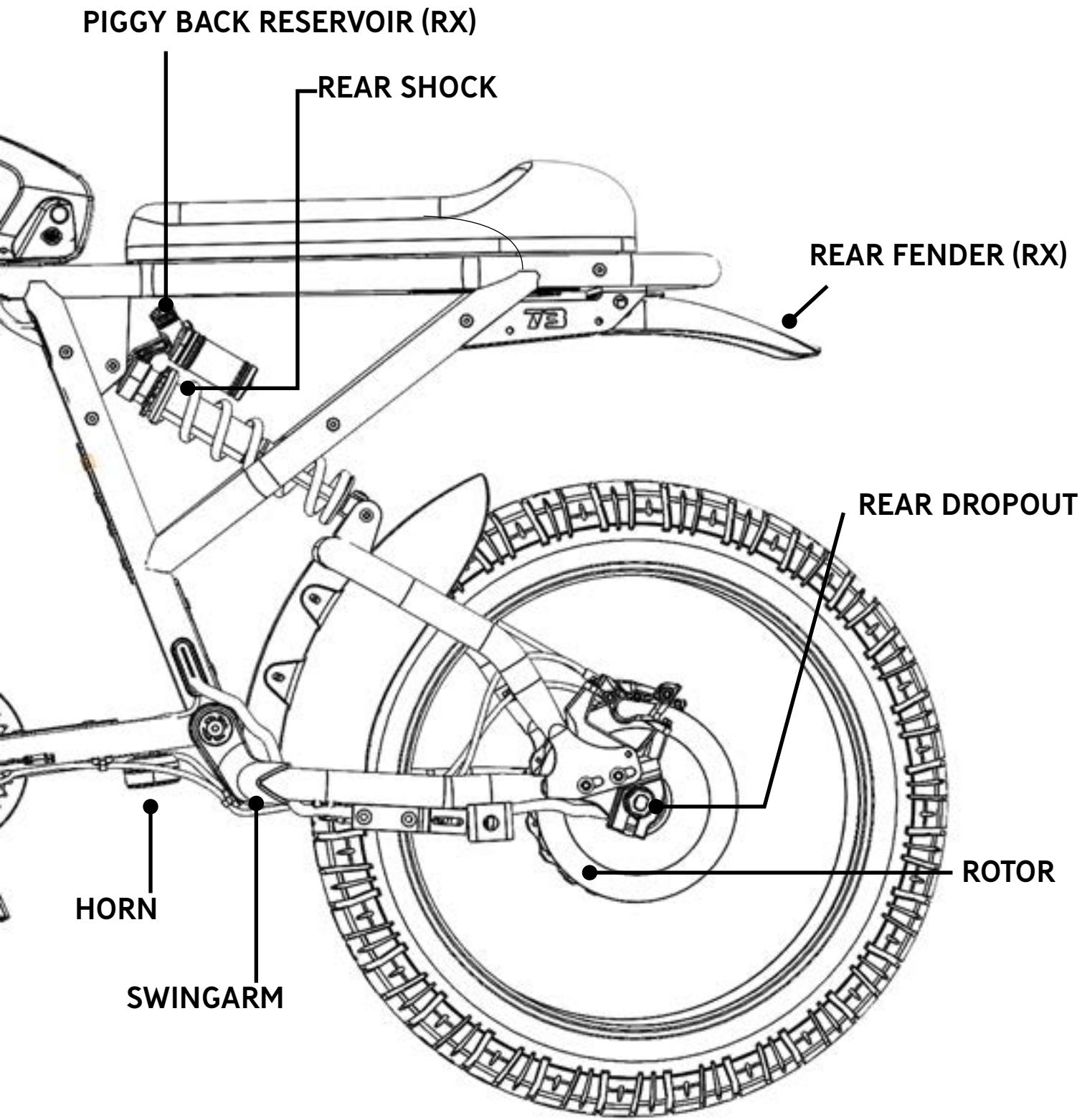

RX model shown. Some options shown may not apply to the R model.

# LEGAL REQUIREMENTS

 Please check your country or state's regulations on electric bikes before riding. There are variations on age limit, speed, motor wattage, and road accessibility. Visit this website for more information:

<https://peopleforbikes.org/our-work/e-bikes/policiesand-laws/>

In most European countries and Australia, the rules of public traffic valid for bicycles also apply to e-bikes traveling up to 25 km/h. However, there are some notable differences (such as the age limit of the cyclist). More information here:

<http://bike-eu.com.s3-eu-central-1.amazonaws.com/app/uploads/2015/09/rules-regulation-on-electric-cycles-in-the-european-union-may-2017.pdf>

**For the latest information on assembly and maintenance, please visit the support section of [www.Super73.com](http://www.Super73.com) or [eu.super73.com](http://eu.super73.com)**

## INTENDED USE

No liability or warranty shall be accepted if the use of the Super73 deviates from this intended use, if safety instructions are not observed, in the event of overloading, or if faults are not properly rectified. Similarly, no liability and warranty shall be accepted in the case of assembly errors, willful intent, accidents, and/or if care and maintenance specifications are not followed. Any modification or alterations to the electrical system tuning) voids all claims under warranty and guarantees.

- Your Super73 electric bike is designed for use on paved paths only. You should therefore never ride on stairs, jump, or perform wheelies or similar activities.
- Super73 electric bikes are not approved for participation in competitions.
- Commercial use does not form part of the intended use.
- Operation parameters, maintenance, guidelines, and service instructions described in this manual are part of the intended use.



Please observe the permitted overall weight of 325 lbs (147kg).



### **DANGER!**

If the user rides the Super73 beyond its intended use, there may be a risk of an accident, serious injury, or death and the risk of injury to those around the user.



# UNPACKING INSTRUCTIONS



## DANGER!

Please read the instructions entirely before assembly to ensure the proper functioning of the Super73. Failure to do so could result in serious personal injury or damage to the bike.



## VIDEO

View our assembly video to follow step-by-step instructions on our website in the Support section at [www.super73.com](http://www.super73.com)



- Do not open box from the top
- A second person is recommended to help unpack and assemble your Super73

1. Remove the 4 plastic tabs at the bottom of the package by pulling the D ring tab out causing the entire piece to pull out.
2. Remove the top lid of the box completely off the bike and bottom portion.
3. Locate the charger and assembly tool kit and set aside.
4. Open the cardboard tabs on the front of the lower portion of the box, lay the tire insert down, roll the bike out from the box, and engage the kickstand to prepare bike for assembly.
5. Please **read all assembly instructions in full** before beginning the build of your new bike.



If any serious damage has occurred to your Super73 during transit, please submit photos to Super73 directly by emailing us at [customer@Super73.com](mailto:customer@Super73.com)

## IN THE PACKAGING

- 1 x lithium-ion battery
- 2 x keys for the battery
- 2 x reflectors
- 1 x battery charger
- 1 x set of pedals
- 1 x two-sided open-end wrench with 15mm and 13mm ends
- 1 x 5mm hex wrench

## ADDITIONAL RECOMMENDED TOOLS:

- 2.5 mm hex wrench
- 4 mm hex wrench
- Spanner tool
- Shock pump with Schrader valve
- Torque wrench

## GOOD TO KNOW:

- Bolts for the handlebars mount are M6 X 12mm socket head cap screws
- Right pedal has the letter "R" inscribed on it, the left pedal has the letter "L" inscribed on it.
- 5mm hex wrench can also be used to adjust brakes.
- Tire tubes size is 20"x5" or 20"x4.5" for the rear and front tires with Schrader valve.



## DANGER!

Before performing any work on your Super73, turn off the power system and remove the battery. Be sure to also turn off the power system and remove the battery during transport in a vehicle. Involuntary activation of the electrical assistance system presents a risk of damage or injury.

# ASSEMBLY INSTRUCTIONS



## DANGER!

Do not ride with a bike that has not passed 100% safety verification before each ride as described in the section pre-ride safety check on pg. 14.

### I. HANDLEBAR INSTALLATION

- A. Use the **5mm hex wrench** to remove the bolts of the handlebar clamp.
- B. Once the clamp is open, place the lower crossbar of the handlebar in the groove of the top crown.
- C. Loosely tighten the handlebar clamp with the **5 mm hex wrench**, and adjust the angle of the handlebar to riders comfort.
- D. Cross tighten the handlebar clamp from corner to corner making sure the clamp is tight and handlebars do not move.



## 2. INSTALL PEDALS

- A. Install and tighten the pedals using the **15 mm open wrench**. Look for a letter marking "L" "R" on each respective pedal and make sure you install the left pedal on the left crank, the right pedal on the right crank.
- B. The right pedal is screwed on in a clockwise direction. The left pedal is screwed on by turning it counter-clockwise.



You may also use a **6mm hex wrench** at the tip of the pedal threading. We recommend adding anti-corrosion paste.

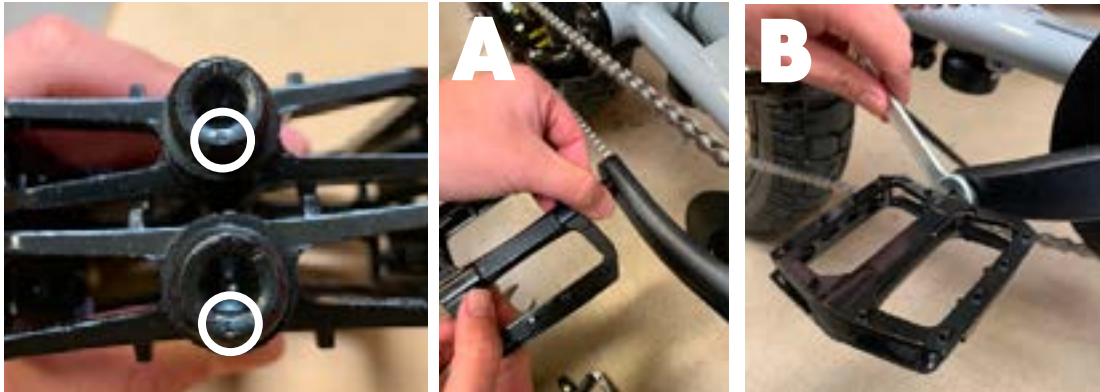

## 3. (REAR DERAILLEUR AND GEARING)

If you have a European model or have added speeds on your bike, make sure to check that your chain and derailleur is properly aligned by looking at the derailleur from the rear.

The two pulleys should be lined up exactly underneath one another, so that the chain runs straight up from the tension pulley to the jockey pulley, with no sideways slant. Compare the line of the pulleys with that of the sprockets above them.

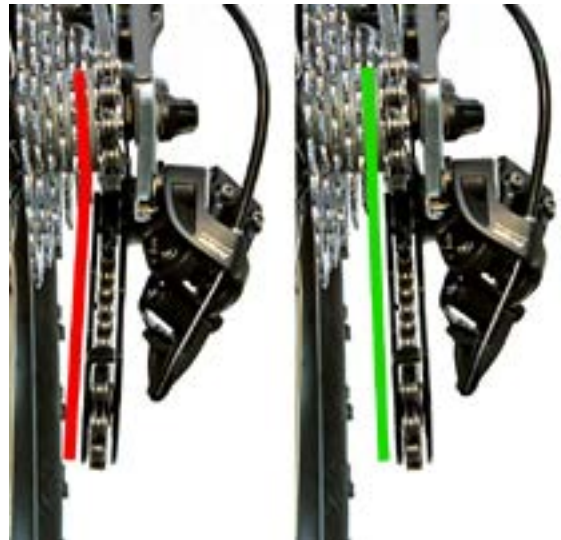

## 4. TIRE INFLATION

For transport purposes, tires are packed partially inflated. Tires must be inflated using a pump with a Schrader valve tip to a recommended 27 - 30 psi (1.86 - 2.06 bar).

- A. Inflate the tube to a max pressure of 35 PSI in order to ensure the tire is properly seated in the rim.
- B. Once properly seated, deflate to a recommended 27 - 30 PSI (1.86 - 2.06 bar). PSI will vary based on the weight of rider and type of terrain.



The inner tube size is 20"x5" or 20"x4.5" for the rear and the front.



## 5. CHARGE THE BATTERY



We recommend charging the battery for 6-8 hours on the first charge. This will help top-off the lithium-ion cells for optimal performance.

The battery can be charged both mounted on the bike or separately from the bike. Two keys are supplied to unlock and lock the battery.

- A. Plug in the charger into a 120v wall outlet. (110-220v EU)
- B. Connect the charger cable to the battery charging port.
- C. Turn the battery on by pressing the power button. The battery is on when the power button is illuminated. The battery will not charge unless it is switched on.
- D. The throttle is disabled during the charge sequence and a charge icon will show on the display during the charging process.

When the charging process starts, the charger LED turns red. Once the battery is charged, the LED turns green.

- A. Turn the battery off.
- B. Remove the charger cable from the battery charging port.
- C. Remember to put the protective cap back onto the battery charging port after charging to protect it from dirt and moisture.
- D. Unplug the charger from the socket.



Always make sure there is plenty of ventilation and a dry, fireproof environment for the charger and follow these operating instructions.

- Do not leave the battery connected to the active charger for more than 48 hours.
- Do not leave the charger connected to a socket for more than 48 hours.
- Charge the battery and use the bike at least once every 90 days.
- Do not store the bike for more than 24 hours with an empty battery. This prevents a deep discharge with irreparable consequences from occurring.
- Do not use the charger if the charger, main cable or connector cable have any visible signs of damage.
- After being charged, if the battery remains connected to the charger, it will turn on and off again in short spurts of green light. This is not a defect. It simply indicates that individual battery cells are being slowly charged. Nevertheless, make sure that the battery is not connected to the charger for more than 48 hours.



More information on battery care and range in the Maintenance and Components section

## BATTERY RANGE

Power output will vary depending on battery capacity. If your battery is at 20%, for example, it won't have as much power as a fully charged battery. If your Super73 has been shipped to you along with the battery, please fully charge the battery first. When a battery leaves the factory, it's not fully charged as required by international air and sea legislation. Battery is fully charged when the LED light on the charger is green.



More information on optimizing range in Maintenance and Components section of this manual.

## ASSEMBLY IS FINISHED!

 You're almost ready to ride. Your Super73 should look like below. **Before your first ride,** please verify your bike is safe to ride using the Pre-ride safety check.

### PACKAGING & RECYCLING

We recommend keeping your bike box packaging for a few days before recycling it in the paper recycling bin.



### REGISTER YOUR SUPER73

All original owners must register their purchase on our website to validate your warranty. Scan these QR codes by hovering your camera feature with your smart phone:

Or on your browser, select these links depending on your location:

- USA: [super73.com/pages/register](https://super73.com/pages/register)
- EU: [eu.super73.com/pages/register-product](https://eu.super73.com/pages/register-product)

**USA**



**EUROPE**



If you can't register online, please call or email us for assistance. Write down below the following information for future reference:

Location or website of purchase: \_\_\_\_\_

Date of purchase: \_\_\_\_\_

Model name: RX

Bike Serial #: \_\_\_\_\_

(Located on the underside of the bottom bracket in between the pedal cranks)

Battery Serial #: \_\_\_\_\_

Battery Key #: \_\_\_\_\_

 We recommend that you keep your original receipt with this handbook.

# PRE-RIDE SAFETY CHECK



## **DANGER!**

Use the following checklist before each ride to verify your bike is safe to ride.

Never operate your bike and use your app simultaneously.



Make sure the brakes have already been applied before getting on to your bike. If the assistance mode is turned on, your E-Bike will start moving as soon as you push on the pedal. The unfamiliar push can otherwise cause a fall, hazard, or accident.

## **1. WHEELS**

- Check the condition of both tires making sure the tread is in good condition free from punctures, cracks, and deformations.
- Maintain proper tire pressure. We recommend a range of 27 - 30 psi (1.86- 2.06 bar) dependent on the weight of rider and type of terrain.
- Ensure wheels are true and properly dished.
- Make sure that the wheels are properly seated in the dropouts and that the wheel nuts are tight and secure.
- Check proper wheel alignment and that derailleur is not bent.

## **2. BATTERY**

- Check that the battery is inserted securely: push the battery into its holder until it clicks into the lock. Remove the key from the lock and pull the battery to check if it has indeed locked into place.
- Check the charge status of the battery. Familiarize yourself with battery charging and storage best practices.

## **3. BRAKES SYSTEM**

- Pull both brake levers. You should feel an obvious pressure point and the levers should not be able to touch the handle.

## **4. LIGHTING**

- Check if the front and rear lights are working properly. Do not cover any lighting or reflectors. (if applicable)

## **5. CABLES**

- Look out for any loose cables.
- Make sure the male and female plugs are properly connected.
- There should be no strain on any wiring near the fork when turning the handlebars from left to right.
- Verify that the wiring on the frame is secure and free from any moving parts that may damage the wiring. This includes any wires and brake cable lines near the wheel or other moving parts.

## **7. KICKSTAND**

- Make sure that the kickstand is tightly secured, and not rubbing against the ground or tires.



Do not sit on a bike with a kickstand engaged!

# OPERATING THE BIKE



## **DANGER!**

Batteries that have not been fully inserted and locked can come loose during a ride and fall out. This can cause a crash and damage the battery.



**DANGER!** Do not inadvertently place the key or any other metal object into the charging port or battery contacts as this can result in a short circuit and render your battery nonchargeable and in need of replacement. This will void the warranty.

## I. POWERING BIKE ON



- Disengage the kickstand, grab the brake handle to engage the brakes, and seat yourself on the Super73.
- Press the battery power button to turn the bike on.
- Once the display screen is illuminated, the throttle or pedal assist is active and you're ready to ride.

## 2. CHANGING THE INFORMATION VIEWED ON THE DISPLAY



- Quick press "O" button to toggle the information viewed on the display.
  - Speed (mph)
  - Range (miles)
  - Assist (0-4)
  - Total (miles)

## 3. OPERATING LIGHTS



The Super73 RX model comes equipped with a front headlight and rear brake light.

- To activate the front headlight, press and hold down the UP "↑" arrow button on the display until the light illuminates. Follow the same step to turn off the lights.
- The rear brake light will automatically be illuminated when the bike is powered on. The rear light will get brighter when the brake levers are engaged.
- You can also activate the lights via the App



Do not use the App while riding. Pull over and stop beforehand.

#### 4. PEDAL ASSIST



- To view your pedal assist mode, follow these steps once the display has been turned on and you are seated on the Super73:
- Press on the menu "O" button briefly to switch between display views until "Assist" appears on the screen.
- Press the up "∧" button to increase the pedal-assist level. To decrease the assist level, press the down "∨" button. Pedal assist ranges from 1-4, with 0 meaning pedal assist is turned off. The higher the level, the more electric assistance you'll get, and the less you'll have to pedal.
  - Level 1 (ECO) - 25% Speed Power
  - Level 2 (TOUR) - 50% Speed Power
  - Level 3 (SPORT) - 75% Speed Power
  - Level 4 (SUPER) - 100% Speed Power
- Once you begin pedaling, the pedal assist sensor will activate the motor and you will begin to accelerate to the selected assist level.
- The display will revert to previous viewing mode after desired assist level is chosen.

#### 5. BRAKING



- The brake levers are equipped with brake sensors that cut power to the motor when either of the levers are compressed. The RX employs the Tektro Dorado hydraulic brake systems in the US, and Magura Magura MT-5e on the European models. The right lever will activate the rear brakes when compressed and the left lever will activate the front brakes when compressed.
- The Super73 brake orientation is as follows:
  - Rear brake = right lever**
  - Front brake = left lever**

#### 6. SETTINGS MENU



- Hold down the "O" button on display to activate the settings menu.
- Settings parameters:
  - Contrast (display window contrast 0-100)
  - Units (standard is set to mi/F)
  - Position (changes the orientation of display if it is on the left or right side of the bike)
  - Backlight (display backlight power 0-100)
  - Version is the software version of the system.
  - Coin is the battery level inside display.



## 7. CHANGING RIDING MODES

Your Super73 is equipped with MultiClass Mode Selection. The bike defaults to a Class 2 mode in the USA, and Mode I in Europe. It is the rider's responsibility to follow local E-bike regulations. Be sure that you are up to date with your local motor vehicle codes.

**TIP** To change the riding mode, follow instructions detailed in the mobile app controlling your display. Once in the app, you can change between the following riding modes:

### USA / North America

Class 1 - pedal assist only at 20 mph max speed.

Class 2 - throttle operation and pedal-assist at 20 mph max speed.

Class 3 - pedal-assist only, at 28 mph max speed.

Unlimited - up to 2000 watts of power and throttle speeds above 28mph\*\*

This mode is exclusively for riding off public roads and on private property.

### Europe, 4 Riding Modes

Mode I/ Default Mode: EPAC (Electrically Power Assisted Cycles) with Pedal Assist at up to 25 km/h 250-watt motor output (street legal for all European countries)

For Modes 2-4, please refer to our website: <https://eu.super73.com/pages/off-road-experience-ore>. Notes that modes 2-4 are exclusively for riding on private property.

In each riding mode, you have 4 Pedal Assist Levels (PAS). In total, there are 16 configurations you can choose from. For example, you can be in Riding Mode I: PAS Level 3.

To activate the "Unlimited Mode", users need to acquire the Off-Road Experience (ORE kit) as well as activate that mode on the Super73 App.

When the bike is turned off, the next time it is turned on it will once again default to the EPAC 250w Riding Mode I which will limit the power (250w), speed (25 km/h) and will disable the throttle if one has been added to the bike.

To activate it again, you need to enable it on the app.

**TIP** More information on switching through Multi-Class Modes in the App section of this handbook.

## 8. TURNING OFF THE BIKE



- When you are done riding your Super73 it is important to turn off the power properly.
- Turn off the bike by pressing the power button on the battery. The light on the power button should turn off when properly powered down. The bike is featured with automatic shut off when left idle for more than 5 minutes.
- You can charge the battery while it's on the Super73, or by removing the battery from the mount and charging it separately.

# SUSPENSION ADJUSTMENT GUIDE

The R-series defaults to a baseline setting. Follow the guides below to adjust the suspension to your desired comfort level. The RX is equipped with an inverted coil-spring fork with air assist and the ability to adjust preload and rebound damping. The rear suspension is a coilover piggyback mono shock with the ability to adjust preload, compression, and rebound damping. The R is equipped with a standard front coil suspension fork and only allows adjustment to the rear suspension.



If any of the instructions are beyond your skill set, we recommend taking your Super73 to a certified E-Bike specialist or professional cycle mechanic for adjustments.



Changing suspension adjustment can change the handling and braking characteristics of your Super73. Never change suspension adjustment unless you are thoroughly familiar with the suspension system instructions and recommendations, and always check for changes in the handling and braking characteristics of the Super73 after a suspension adjustment by taking a careful test ride in a hazard-free area.

## FRONT SUSPENSION ADJUSTMENTS

### Adjusting Air Compression

Adjustment of air compression will require a shock pump. Use Figure I “suggested starting air pressure” on pg. 20 to find your recommended air pressure.



- Remove the valve cap on the bottom right side of the front fork and connect your shock pump to the pressure valve.
- Review the current air pressure and adjust according to Figure I. finetune the pressure with the shock pump to your desired comfort.
- Be sure you remove the shock pump in between adjustments as leaving it on can affect the active pressure in the suspension. After completing adjustment, reinstall the pressure valve cap.

### Measuring Sag

The recommended sag of the front fork is 20mm into the travel, which can be measured with the o-ring found on the lower portion of the right stanchion. To measure sag, place your bike somewhere level where you can safely put your full weight on the bike while balanced. It is recommended to have a friend help balance the bike during this portion of adjustment.



- Slide the o-ring all the way up to the bottom of the air chamber. Then seat yourself on the bike, engage the brakes, and move into an aggressive standing position with your feet on the pedals.
- Dismount from the bike and measure the amount of travel between the o-ring and the air chamber. If the measurement is more or less than 20mm, start with adjusting the air compression appropriately and then fine-tune by adjusting the preload.



### Adjusting Preload

Preload is adjusted with the dial on the top left stanchion.

- Turning the preload dial clockwise (+) will increase pressure on the spring coil.
- Turning the dial counterclockwise (-) will decrease pressure on the spring coil.



### Adjusting Rebound

Rebound is adjusted with the dial on the top right stanchion.

- Turn the rebound dial clockwise to slow your suspension rebound (damper increase).
- Turn the rebound dial counterclockwise to speed up the rebound (damper decrease).

## REAR SUSPENSION ADJUSTMENTS

### Measuring Sag

To measure sag, place your bike somewhere level where you can safely put your full weight on the bike while balanced. If you don't have a way to safely balance the bike during this step, have a friend help balance the bike during this portion of adjustment.



- Sliding the bumper all the way up to the shock chamber. Then seat yourself on the bike, engage the brakes, and put your full weight on the bike. Dismount from the bike and measure the amount of travel between the bumper and the shock chamber.
- If it is more or less than 20mm, start by adjusting the compression and then fine-tune with preload adjustment.



### Adjusting Preload

Preload is adjusted with the spring nut at the top of the spring coil.

- Turn the spring nut at the top of the spring coil clockwise to increase pressure on the spring coil.
- Turn the spring nut counterclockwise to decrease pressure on the spring coil.

**TIP** When adjusting the pressure on the spring coil, you may need a spanner tool to adjust if you can not hand tighten to the desired pressure.



### Adjusting Compression

To adjust compression, turn the dial at the top of the piggyback reservoir on the rear shock.

- Turn the dial clockwise (+) to increase pressure.
- Turn the dial counterclockwise (-) to decrease the pressure.



### Adjusting Rebound

Rebound is adjusted using the dial at the base of the mono-shock.

- Turn the rebound dial clockwise to slow your suspension rebound (damper increase).
- Turn the rebound dial counterclockwise to speed up the rebound (damper decrease).

**Figure I**

<b>SUGGESTED STARTING AIR PRESSURE</b>			
<b>LBS</b>	<b>KG</b>	<b>PSI</b>	<b>BAR</b>
125	57	100	6.9
145	66	105	7.2
165	75	110	7.6
185	84	115	7.9
205	93	120	8.3
225	102	125	8.6
245	111	130	9
265	120	135	9.3
285	129	140	9.7
305	138	145	10
325	148	150	10.3

**Pressure Limits**

Minimum: 100 PSI

Maximum: 150 PSI

**Fork Suspension Torque Specs (Torque Wrench required for adjustment)**

- Axle Clamps - 6 ft/lb (8.14 N m)
- Axle - 5 ft/lb (6.78 N m)
- Upper Stanchion Clamps - 6 ft/lb (8.14 N m)
- Lower Stanchion Clamps - 6 ft/lb (8.14 N m)
- Steer Tube Clamp - 8 ft/lb (10.85 N m)

# SUPER73 APP



Never ride and adjust settings on your app while in motion. Pull over and practice safe riding. By operating your bike and the app simultaneously you put yourself at risk for collision and serious injury.

## IN NORTH AMERICA

Each RX bike comes programmed in the Class-2 ride mode, which allows for throttle operation and pedal-assist riding up to 20mph. This allows the ZX to be legally ridden on most bike paths without a license, insurance, or registration.

- Class-1 Mode: up to 20mph (throttle deactivated, pedal assist only)
- Class-2 Mode: up to 20mph with throttle or pedal assist
- Class-3 Mode: up to 28mph (throttle deactivated, pedal assist only)
- Unlimited Mode: up to 28mph with throttle or pedal assist\*

\*Please note Unlimited Mode is intended for private property or off-road use only

## IN EUROPE / MODELS WITHOUT THROTTLE

Please check our website for instructions or ask your dealer.

Link: <https://eu.super73.com/pages/off-road-experience-ore>

# GENERAL WARNINGS

Like any sport, cycling involves risk of injury and it is the rider's responsibility to assume potential risks and injury involved when riding. By choosing to ride a bicycle, you assume the responsibility for that risk. You need to know and practice the rules and safety regulations of riding this bicycle. Proper use and maintenance of your bicycle reduces risk of injury. Check your local state or country regulations for electric bike laws. For example, check the minimum age for using an electric bike as this differs in various regions.

Riders must have the physical condition, reaction time, and mental capability to ride and manage traffic, road conditions, and sudden situations. Also, respect the laws governing E-bike use in accordance with each region. If you have an impairment or disability (i.e. visual impairment, hearing impairment, physical impairment, cognitive/language impairment, seizure disorder, etc.), consult your physician before riding any bicycle.



**NOTICE:** Only take on tasks for which you have the necessary knowledge and tools. It is recommended that users pay special attention to all of the general operating rules below before operating their Super73 bike.

- When riding, obey the same road laws as all other road vehicles, including giving right of way to pedestrians and stopping at red lights and stop signs.
- For additional information, contact the road traffic authority, police department or Department of Motor Vehicles in your state or country.
- Use correct hand signals to indicate turning or stopping.
- Concentrate on the path ahead. Avoid potholes, gravel, wet or oily roads, curbs, train tracks, speed bumps, and other obstacles.
- Walk your bike across all train tracks.
- Expect the unexpected, such as opening car doors or cars backing out of driveways
- Be aware at intersections and when preparing to pass other vehicles or other cyclists.
- Familiarize yourself with all the bike features. Practice using the brakes and throttle in a safe place without traffic.
- If you are wearing loose pants, secure the bottom using leg clips or elastic bands to prevent them from being caught in the chain.
- Wear proper riding clothes and avoid wearing open-toe shoes.
- Don't carry passengers or cargo that will interfere with your ability to control the bicycle.
- Never ride and use the app simultaneously. Pull over and adjust any settings or set your destination in the navigation in a safe spot.
- Don't use music devices such as headphones while riding. This will restrict your hearing and impair your awareness of your surrounding environment.
- Maintain a comfortable stopping distance from all other objects, riders, and vehicles. Safe braking distances are based on forces, such as weather and lighting conditions among other variables.



## WET WEATHER

Take extra care while riding in wet conditions. The Super73 is not meant for use in puddles, heavy rain, and streams. Never immerse this product in water as the electrical system may be damaged. Take extra care while riding in wet conditions. Feet or hands can slip in wet conditions and lead to serious injury from a fall. Brake earlier as it will take longer to slow than when operating in dry conditions. Decrease riding speed. Wear reflective clothing and use approved safety lights. Road hazards are more difficult to see when wet, proceed with caution.

## **RIDING AT NIGHT**

Be safe! It is recommended to take extra precautions while riding at night. Ensure your Super73 is equipped with a full set of correctly positioned and clean reflectors. Use a properly functioning lighting set comprised of a white front light and red rear light. Wear reflective and light-colored clothing. Slow down and use familiar roads with street lighting, if possible. Check your local regulations regarding lighting requirements for bicycles.

## **FOR PARENTS AND GUARDIANS**

As a parent or guardian, you are responsible for the activities and safety of your child. Please check your local state and country laws for age restrictions.

# **SAFETY**

The following safety notes provide additional information on the safe operation of your Super73 and should be closely reviewed. Failure to review these notes can lead to serious injury or death.

## **RIDING**

- All users must read and understand this manual before first use. Additional manuals for components used on your bicycle may also be provided and should be read before use in addition to this manual.
- Always wear an approved bicycle helmet whenever using this product and ensure that all helmet manufacturer instructions are used for fit and care of your helmet. Failure to wear a helmet when riding may result in serious injury or death in the event of an accident.
- Ensure correct tightening and setup is performed on your bicycle after assembly.
- It is your responsibility to familiarize yourself with the laws and requirements of operation of this product in the area(s) where you ride.
- Ensure handle bar grips are not damaged and properly installed. Loose or damaged grips can cause you to lose control and fall.
- Bicycles and bicycle parts have strength and integrity limitations and extreme riding should not be performed or you risk damaging the components or becoming seriously injured.
- After any incident you must consider your bike unsafe to ride until an inspection is made according to provided safety check in the is handbook. Consult with a professional cycle mechanic for a comprehensive inspection.
- Failure to properly charge, store, or use your battery will void the warranty and may cause a hazardous situation.
- Extreme care should be taken when using the pedal assist sensor and propulsion on this product. Ensure you understand and are prepared for the power assistance to engage as soon as pedaling is underway.
- You should check the operation of the brake inhibitor switches before each ride. The brake system is equipped with an inhibitor that shuts down the power to the electric motor whenever the brakes are engaged.
- User must understand the operation of the throttle and pedal-assist levels before using, and take ample care in their usage at speeds appropriate for each region and user experience level. Use the lowest assist level until you are comfortable with the bike and feel

confident in controlling the power.

- Because e-bikes are heavier and faster than normal bicycles, they require extra caution and care while riding.
- Do not remove the front, rear or pedal reflectors.
- Be familiar with your local e-bike laws.
- Any after-market changes to your Super73 bike not expressly approved by Super73 may void the warranty and create an unsafe riding experience.

## **CHARGER**

- Never use this battery charger to charge other electrical devices.
- Do not use any other charger or charging method to recharge the batteries of the electric bicycle. Using any other charger may lead to a fire, explosion or damage to the batteries.
- This battery charger may be used by children aged 8 or over and by persons with physical, sensory or mental impairments, or who lack the necessary experience and knowledge, provided that they are supervised and instructed on how to use the battery charger safely and they understand the dangers involved. Do not allow children to play with the battery charger. Cleaning and maintenance should not be performed by unsupervised children.
- Although the battery charger is water resistant, do not allow it to be submerged in water or other liquids.
- Furthermore, never use the battery charger if the terminals are wet.
- Never touch the power plug, charging port or contacts of the charger with wet hands. You may suffer an electric shock.
- Do not touch the contacts of the charger with metal objects. Do not allow any foreign matter to enter, it may cause short circuits in the contacts, which may cause electric shock, a fire or damage to the battery charger.
- Regularly clean any dust off the power plug. Moisture or other problems could reduce the effectiveness of the insulation and cause a fire.
- Never dismantle or modify the battery charger. You may cause a fire or suffer an electric shock.
- Do not use multi-socket adapters or extension cables. Using a multi-socket adapter or similar may exceed the rated current and cause a fire.
- Do not use with the cable tied up or coiled and do not store with the cable coiled around the body of the main charger. If the cable is damaged it may cause a fire or you may suffer an electric shock.
- Firmly insert the power plug and charging plug in the socket. If the power plug and charging plug are not fully inserted, this may cause a fire due to an electric shock or overheating.
- Do not use the battery charger near flammable materials or gases.
- This may cause a fire or explosion.
- Never cover the battery charger or place objects on it while it is charging. This may lead to internal overheating and cause a fire.
- Do not drop the battery charger or expose it to strong impacts. Otherwise, it may cause a fire or electric shock.
- If the power cable is damaged, stop using the battery charger and take it to an authorized dealer, or contact us.
- Handle the power cable with care. Plugging in the battery charger indoors while the bicycle is outdoors may lead to the power cable being caught on or damaged by doors or windows.
- Do not pass the wheels of the bicycle over the power cable or plug. Otherwise you may damage the power cable or port.



## BATTERY



Do not open the battery. There is a risk of short circuit. Opening the battery will void the warranty. Protect the battery against mechanical damage, heat (in case of prolonged exposure to sunlight), fire, and immersion in water. There is a risk of explosion. In case of damage and improper use of the battery, vapors may emanate. Keep children away from the battery.



Please follow proper charging instructions before charging the battery. To charge the battery, use only the original charger or charger approved by the manufacturer. Remove the battery from the charger and disconnect the charger from the power supply when charging is complete.

The battery is the most important component of your Super73. Following a few simple rules, you can optimize its life:



**DANGER!** Avoid leaving the battery outside. Do not leave your battery exposed to high temperatures or direct sunlight for long periods of time such as on the back of a car in direct sunlight, or leaving the battery on your parked bike). This can lead to overheating and extreme damage.

- Do not store a discharged battery. It could go into deep discharge which will reduce its life.
- Make it a habit to recharge at the end of each ride, so your bike will always be ready to go again.
- Even if it can withstand storage temperatures of 23°F - 104°F (-10°C - 40°C), you can optimize its shelf life by storing it at room temperature 65°-75°F (18° - 23°C).
- Observe operating conditions between 40°F - 85°F (4°C - 30°C).
- Please ensure that the contacts are always clean and do not insert metal objects



**DANGER!** Never charge the battery in a flammable environment. For safety reasons, the charger and the battery must be placed on a dry, non-flammable surface.



Never charge or use a defective battery. Never send a battery by postal mail by yourself! A battery is in the category of hazardous/dangerous goods and requires certification to send by mail. Doing so without proper certification is punishable by law.



Immediately remove the battery from the Super73 if you notice damage to the electrical system and visit your local E-bike Specialist for inspection or contact Super73 directly. Any lack of professional expertise may cause damage or serious injury.

For information on Battery Range, see the Maintenance & Components section.

## BLUETOOTH

- Do not use the wireless Bluetooth function in areas such as hospitals or medical institutions where it is forbidden to use electronic or wireless equipment. Otherwise, this may affect the medical equipment and cause an accident.
- When using the wireless Bluetooth function, keep the screen at a safe distance from any pacemakers in use. Otherwise, the radio waves may interfere with the operation of the pacemaker.
- Do not use the wireless Bluetooth function near to automatically controlled equipment,

such as automatic doors, fire alarms, etc. Otherwise, the radio waves may interfere with the equipment and cause an accident due to a malfunction or unintended operation.

## RECYCLING & END OF LIFE

All electronics such as the motor, battery, charger, display panel, torque sensor and packaging must be disposed of and recycled responsibly.

- Do not dispose of the bicycle or its components together with household waste.



### IN EUROPE

Pursuant to Directive 2012/19/EU and Directive 2006/66/EC, electrical devices/tools that can no longer be used and defective or used battery packs/batteries must be disposed of and recycled separately and in an environmentally friendly way. Hand over any batteries that can no longer be used to an authorised bicycle supplier.

To see where to recycle your batteries or electronics, visit <https://eu.super73.com/pages/recycling>



Users legs should be at least 30"-31" (76-79cm) long to ride the Super73.

# MAINTENANCE SCHEDULE

In order to prolong the life expectancy of your bike, here is an example of a maintenance schedule, under intended use, that we recommend the following:



## **DANGER!**

Intensive use of the Super73 may cause possible damage to the frame and the fork. It is important to inspect the frame and the fork and look for signs of cracks. A broken or cracked frame and fork can cause an accident and injury. Refer to the Intended Use section.

## **I. BEFORE AND AFTER EACH RIDE**

- Check the alignment of the wheels.
- Check the state of charge of the battery.
- Check that brakes function properly.
- Check tires for any punctures, and wheels for proper alignment.
- Store the bike carefully in a clean and dry place.
- Check that your kickstand is tightly secured.
- Check for loose cables or wires that may be strained when turning the front wheel from left to right.

## **2. EVERY MONTH**

- Inspect the handlebar and steer tube for any unusual movement.
- Check the cables, tires, handles.
- Check the wear of brake rotors, brake pads (see section on brakes), and replace them if necessary, and replace them if necessary.
- Check the tension of the spokes, and ensure that the wheels are true and properly dished.
- Lube the chain and check the tension in the chain. It should be tight enough that it only allows you to move it up and down about one inch. If it is sagging or much looser than that, you need to tighten the chain.
- Inspect suspension components for wear and make any necessary adjustments.

## **3. EVERY SIX MONTHS (depending on frequency and type of use)**

- Inspect the frame, fork and look for signs of cracks in the metal.
- Check the bottom bracket and crankshaft and tighten the bolts on each crank.
- Check and grease the wheel hubs, headset, all parts in friction.
- Grease suspension components and tighten any necessary hardware.



For your own safety, if any of the recommended maintenance procedures are not within your skill set, we advise taking your Super73 to an E-bike specialist or professional cycle mechanic for inspection.

# MAINTENANCE & COMPONENTS



## **DANGER!**

Before performing any work on your Super73 electronics system, turn off the system and remove the battery. Involuntary activation of the Super73 system poses a risk of injury.

## **TIRES / WHEELS**

The R-Series has tire sizes of 20" x 5" (rear) and 20" x 4.5" (front) rubber tires with inner tubes and a rim liner. The tube size for both the front and rear tires is 20" x 4.5" or 20" x 5". The tires are designed for durability and safety for regular cycling activities. However, tires must be checked before each use for proper inflation and condition.

Proper inflation, good maintenance, and quick replacement will help ensure that the operational characteristics of your bike will be maintained and dangerous conditions avoided.

Tires must be inflated using a pump with a Schrader valve tip with a recommended pressure between 27 and 30 psi (1.86 -2.06 bar). Check the condition of the tires and rims for damage, cracks or deformation. The recommended tightening torque of the wheel nuts is 16ft/lb (20 Nm).



It is essential that the proper air pressure is maintained in the tires all the time. Do not under-inflate or over-inflate your tires. Low pressure can cause loss of control and tires that are too inflated can burst. Failure to maintain proper air pressure rating indicated in the handbook may at any time result in tire and/or wheel failure.

Inflate your tires from a regulated air source with an available manometer. Inflating your tires with an unregulated air source could over-inflate them, resulting in an exploded tire. When tire wear becomes obvious or a hole in the tire is found, you must replace the tires and / or tubes before using the bike, otherwise injury to operators and / or damage to your bike could occur.



In addition to proper inflation, correct wheel alignment helps to decrease tire wear. If you find a tire is worn unevenly, have a professional cycle mechanic check the wheel alignment.

## **CHAIN TENSION (USA)**

The R-series is equipped with a chain tensioner. It is recommended that you inspect the chain tensioner for wear and periodically lube the chain. It should be tight enough that it only allows you to move it up and down about one inch. If it is sagging or much looser than that, you need to tighten the chain.

To apply bike chain lube, deposit a drop on the top of each link as you slowly backpedal for a few revolutions, so the lube has a chance to work its way in. Wipe off excess lube—if you don't, it can attract more dirt to your chain. Be careful to not get lube in the brake calipers or pads.

## **HELMETS / REFLECTORS**

A properly fitting ANSI or SNELL, (or CE if you are located in Europe), approved bicycle safety

helmet should be worn at all times when riding your bicycle, or recommended per your local laws. Always wear a properly fitted helmet that covers the forehead when riding a bicycle. Many states require specific safety devices. It is your responsibility to familiarize yourself with the laws of the state where you ride and to comply with all applicable laws, including properly equipping yourself and your bike as the law requires.

Reflectors are important safety devices that are designed as an integral part of your bicycle. Federal regulations require every bicycle to be equipped with front, rear, wheel, and pedal reflectors. These reflectors are designed to pick up and reflect street-lights and car lights in a way that helps you to be seen and recognized as a moving bicyclist. Check reflectors and their mounting brackets regularly to make sure they are clean, straight, unbroken, and securely mounted.

## **BRAKES**

 Brakes are an integral part of the operation of your bike and must be properly maintained, adjusted, and replaced. If any of the below is not within your skill set we recommend taking your bike to an E-bike specialist or professional cycle mechanic

 Hydraulic brake lines require maintenance not only on the pads and rotors but also on the hydraulic brake line. Brake pad replacement, check to see if the rotor and pads have contact with each other.

For optimum braking performance, Super73 bikes are equipped with Tektro hydraulic disc brakes and Magura brakes. See video on our website on how to adjust: [www.super73.com/pages/owners](http://www.super73.com/pages/owners) or visit Tektro and Magura's websites.

The Super73 brake orientation is as follows: Rear brake = right lever & Front brake = left lever

### **Brake Models:**

Model RX (USA): HD-E730 <https://www.tekro.com/products.php?p=254>

Model RX (Europe) : Magura MT5e <https://www.magura.com/en/components/bike/s-pedelec-brakes/productdetailpage/?p=2594>

Model R (USA): HD-E350 <https://www.tekro.com/products.php?p=242>

### **Brake pads:**

Model RX: QIITS: <https://www.tekro.com/products.php?p=256>

Model RX (Europe) : MT-5e brake pads, Cyclotech Prodisc E-bike

Model R: A10.II: <https://www.tekro.com/products.php?p=226>

On a hydraulic disc brake, pad wear is compensated automatically. Simply check the alignment of the pads with the disc, and check that the wheel is fully pushed back. Good alignment ensures the absence of noise and a normal wear of the pads. To ensure maximum service life of the brake components, avoid contamination of the pads and the disc by greasy substances.

 Regularly check the condition of your cables, ducts or harness and the wear of your pads. Some discs are only compatible with "resin" pads. Do not use a metal pad with discs marked "Resin".

For better ergonomics and safety, we advise you to adjust the brake levers in a position that places it as a natural extension of the user's arms. If you have any questions or concerns, please contact Super73.

## NEW BRAKE PAD & ROTOR BED-IN PROCESS

Any time you replace your brake pads, rotors, or both, it is important they are properly bedded for optimal performance. To bed your brakes properly after replacement, accelerate your bike up to 20mph or 25 km/h and then engage your brakes to bring the bike to a near stop, and then repeat the process up to 8-10 times. This process allows your pads to wear evenly as well as remove surface glaze and contamination from installation.

## REPLACING THE PADS

Check for wear by looking at your brake pads through the spaces between the wheel's spokes. The outside pad will be pressed against a metal rotor. Generally, there should be at least 1/4 inch of pad. If you see less than 1/4 inch (0.6 mm) of pad, you may want to have your brake pads inspected or replaced.

When pads are worn, make sure to adjust both clearances between the rotor and pad so that they are equal and balanced. If only one side is adjusted it will cause braking failure.

1. Pads and pad holders are held in place by a 3 mm pad retainer bolt on the caliper. To remove the pads and pad holder, unscrew the retainer bolt, then gently push out the pads and holder. This may be easier to achieve by using an Allen wrench.

2. Once free of the caliper, the pads may be easily removed from the pad holder.

 It is highly recommended that you wear rubber gloves when handling new brake pads, as direct contact with your hands can contaminate the pads and/or rotor during installation. Contaminated brake pads and rotors can negatively affect braking performance.

## BRAKE WARRANTY

For any manufacturing problems or questions related to Tektro brakes, you can contact the local Tektro representative: <http://www.tektro.com/service-a.php?t=2>

For Magura warranty, please visit here: <https://www.magura.com/en/components/techcenter/>

## BATTERY RANGE

The maximum range of a full charge depends on many variables such as: age of battery, type of terrain and incline, rider weight, speed, outside temperature, driving style, amount of pedaling, or tire pressure.

### Range in cold weather:

- In case of extreme cold, the range of your electric bike is reduced. It is a normal physical process, and in no case a damage or defect of the battery. If you use your battery when temperatures rise, it's energy will increase again.
- We advise you to store the battery and charge it at room temperature during cold days. The power consumption warms the battery and you benefit from a good battery life, even when it is cold outside.
- In winter, however, plan for shorter trips or pedal with a lower level of assistance.

### Conditions that affect your battery's range:

- **Temperature:** Extreme cold and heat can affect the battery's capacity.
- **Total Number of Charge Cycles:** As the battery ages, total capacity can decrease. The battery has a total of 1,000 full cycles when it's new.

- **Wind:** Riding into a strong headwind can decrease range.
- **Road Conditions:** Excessively rough or hilly terrain requires the consumption of more power.
- **Load:** Carrying extra cargo on the bike or in a backpack will use more energy.
- **Rider Weight** please observe the max weight of 325 lbs (147kg).
- **Repeated acceleration** from a standing start.
- **Poor Maintenance:** Under-inflated tires, badly-adjusted brakes, a dry or dirty chain, can decrease range.

#### **Tips for Maximizing Range:**

- Charge the battery at a comfortable temperature range between 65°F - 75°F (18.3°C-23.9°C)
- Lithium-ion batteries have no chemical memory, and it is not necessary to discharge the battery completely for the best performance. Charging a partially full battery will have no negative effect.
- Maintain proper tire pressure and lube the chain regularly.
- Operating temperatures between 40°F - 85°F (4°C - 30°C) will significantly increase range.

## **DERAILLEUR (EU model)**

The RX european model is equipped with a 10-speed rear derailleur. It is recommended that you inspect the derailleur for wear and periodically lube the chain. Clean the cassette and chain with biodegradable cleaners only. Rinse thoroughly with water and allow the parts to dry, then lubricate the chain with chain lubricant according to the manufacturer's instructions. Lubricate regularly to extend the chain's service life. The cassette and chain rings should be replaced when a new chain is installed. For more information, visit the manufacturer's website:

- <https://www.sram.com/globalassets/document-hierarchy/user-manuals/sram-mtb/drivetrain/95-7618-001-100-rev-c-2x-3x-mtb-derailleurs-user-manual-eeu.pdf>
- <https://si.shimano.com/api/publish/storage/pdf/en/dm/GN0001/DM-GN0001-24-ENG.pdf>

## **LIGHTING SYSTEM**

The RX model lighting system is wired into the main harness of the electric bike. For replacement, you must disconnect the cables on both the rear brake light and front light and get new parts. There are no batteries in the lights. Make sure the front and rear lights are clean before riding. If they are dusty, or dirty, clean them with a damp cloth for optimal visibility and safety.

## **SEAT**

The seat is fixed to the frame by bolts, so it is not possible to adjust the seat height. The minimum seat clamping torque on the frame is 6.78 (Nm) 5lb / ft. For maintenance, use a cloth and water with a gentle soap for cleaning. Avoid leaving the seat too long in the sun, as the fabric can be damaged by the sun's UV rays. Avoid wearing clothes that may puncture or tear the seat.

## **SUSPENSION**

Suspension components will require regular maintenance, cleaning, and greasing in order to keep the movement of these components fluid and in good working order. It is recommended to regularly inspect each component of the suspension for signs of wear.

 Failure to maintain, check and properly adjust the suspension system may result in suspension malfunction, which may cause you to lose control and fall.

## CLEANING YOUR BIKE

Dirt, salt, and other elements can damage your bike. Regularly clean your Super73 and protect it against corrosion. Use clear water for cleaning and a gentle soap if necessary to dissolve grease and other residues. Do not spray water directly onto your Super73, especially the electronics. Instead, use a lightly damp cloth to wipe down any dirt or debris. After drying your bike, treat surfaces with a care product. Finally, wipe all parts with a clean, soft cloth.

 Do not clean your Super73 with a strong water jet or steam jet from a short distance. The water can get past the seals and get inside the bearings or electronics. Lubricants are then diluted, increasing friction. In the long run, the bearing surfaces will deteriorate.

 The bike is subject to wear and tear, like all mechanical parts. Materials and parts react differently to wear and abrasion. If the intended life of a part is exceeded, it is possible that it will suddenly fail, which represents a certain danger for the rider. Any type of cracks, streaks, or color changes in highly stressed areas indicate the maximum wear of a part. It must, therefore, be replaced immediately. It is important to use genuine properly specified parts for safety-critical components during the replacement of worn parts.

## STORAGE

Keep the bicycle in a place that is:

- Flat and stable
- Well ventilated and dry
- Protected from the elements and direct sunlight

 Do not leave your battery exposed to high temperatures or direct sunlight for long periods of time such as on the back of a car in direct sunlight, or leaving the battery on your parked bike). This can lead to overheating and extreme damage.

## PROLONGED STORAGE

If you are going to store the bicycle for a prolonged period (1 month or more), remove the battery and store it as follows:

- Make sure that the remaining battery capacity is above 50% and then store it indoors, in a cool (10 to 20°C) and dry place.
- Check the remaining battery capacity once a month, as the battery is slowly discharged while in storage. If the capacity is below 50%, charge it until it is above 50%.
- When using it again after a prolonged period of storage, be sure to charge the battery before use.

## WARRANTY US / NORTH AMERICA

Subject to the terms, conditions and limitations herein, Super73, Inc. warrants to the original retail purchaser of the bike that the frame, fork, electronics and battery of the bike will be free from defects in material and workmanship under normal use and service for one (1) year from the date of delivery (the "Limited Warranty"). The Limited Warranty exists for abovementioned defects that were already present at the time of delivery of the bike and covers the battery, motor, controller, display and sensors. Like any rechargeable battery, your Super73 rechargeable



battery pack will experience a decrease in capacity over time as it is subjected to charge and discharge cycles. The battery warranty does not include damage from power surges, use of an improper charger, water damage, improper maintenance, or such other misuse or normal wear. This warranty is only valid for the first buyer. Any other remedy, such as compensation for damages of any kind or loss of use, is excluded. The warranty period cannot be extended by granting an additional warranty.

If the original retail purchaser notifies Super73, authorized dealer or the retail location from where the bike was purchased of a warranty claim within the applicable warranty period set forth above, Super73 will evaluate the warranty claim. The purchaser will be responsible for shipping the bike to the location notified by Super73. If Super73 determines that the defective part is covered by the Limited Warranty, Super73 will replace or repair the defective part, at Super73's sole discretion, without charge to the buyer and also reimburse the shipping cost incurred by the purchaser. If the defective part is not covered by the Limited Warranty, Super73 will repair or replace the defective part at the purchaser's cost and the purchaser will also be responsible for the shipping costs.

- (a) The original purchaser provides proof that the bike was purchased from Super73 or one of its authorized dealers or distributors.
- (b) The person seeking warranty coverage is the original and first owner of the bike (warranty is not transferable in the case of a re-sale).
- (c) The bike was used in accordance with its intended purpose. The Super73 bike is intended for use on paved road.
- (d) The electronics including connectors and cables have not been repaired or modified.

**For more information on our Warranty, Shipping Damage Claims, our Return and Cancellation Policy, please visit [super73.com](http://super73.com) for service in North America.**

## **WARRANTY EUROPE**

Super73 B.V. warrants to the original owner of each of its Super73 motorbike, when purchased directly from Super73 B.V., or an authorized retailer, that the Product is complete and that the functional parts will be free of defects for the periods and under the terms indicated below.

### **Warranty:**

1. A twenty-four (24) month or 500 life cycles, whichever comes first, for the Super73 battery from the date of purchase by the original owner. Like any rechargeable battery, your Super73 rechargeable battery pack will experience a decrease in capacity over time as it is subjected to charge and discharge cycles. Super73 warrants that your battery pack will maintain 70% or higher capacity for at least 500 charge cycles or two years, whichever comes first. The battery warranty does not include damage from power surges, use of an improper charger, water damage, improper maintenance, or such other misuse or normal wear.
2. A twenty- four (24) month, from date of delivery to the original owner for all other parts, excluding wear and tear on tires, tubes, rims, spokes, brake pads, cables, chain, wheels, grips, and saddle and excludes damage from power surges, water damage, improper maintenance, or such other misuse or normal wear.

### **Terms and Conditions of Warranty:**

1. The Warranty is made to the original owner only and is nontransferable. It is only effective with a valid proof of purchase consisting of the original purchase document or receipt indicating the date of purchase, the serial number, the dealer's name (if applicable) and the designation of the model. Super73 reserves the right to reject the coverage of this Warranty

- if the accompanying documentation of the Super73 components is not accurate or complete.
2. The Warranty becomes effective from the date of original purchase and expires at the end of the applicable warranty period.
  3. This Warranty is void if the care instructions in the owner's manual (whether provided with the sale or posted on the Super73 website), and any amendments thereto, are not followed.
  4. This Warranty does not apply to rental or commercial use of the Product.
  5. This Warranty exclusively covers systems and components provided by Super73.
  6. The use of spare parts from unknown sources, for example, replacement parts from third parties is strictly prohibited.
  7. Photo and /or video will be required for warranty inspection by a Super73 Customer care agent.
  8. If you purchased a bike and had it then shipped to another country or outlying island territories (ex: DOM-TOM, Netherlands Antilles), parts will only be sent to the country and mainland European territory in which the bike was originally sent.
  9. This Warranty only covers defective materials and manufacturing defects. In the case of a warranty claim, Super73 undertakes to either repair faulty system components and/or to replace such components, at the discretion of Super73.

Upon identifying a fault with a Super73 bike, the owner must contact the Company or a local authorized Super73 dealer to initiate the warranty process. Any component to be repaired under this Warranty must be transported to the dealer at the owner's own expense and risk, and, after the completion of such repair, must be picked up at the dealer. Costs for repair work performed in advance by persons who have not been authorized by Super73 will not be reimbursed. In such a case, any warranty claim will cease and any remaining warranty period will be voided. Repair work and/ or replacement of components during the warranty period does not lead to an extension and/or a new start of the warranty period. Repair work and direct replacement during the warranty period may be performed with functionally equivalent replacement components. This Warranty excludes any claims as to the reimbursement of property damages, downtimes, travel expenses, lost profit, or any other claims. Super73 maximum liability in connection with this Warranty is limited to the purchase price of the Product.

#### **I. Exclusions – Items not covered under Warranty**

2. External influences, mainly falling rocks, collision, accident, and other external events with an immediate external effect due to mechanical powers.
3. Purposeful and/or malevolent acts, theft, and robbery as well as natural hazard events and/or acts of mischief. Inappropriate use, e.g., the Product was exposed to liquids, chemicals of any type and/or extreme temperatures, wetness and humidity and/or if the battery suffers damages due to non-compliance with the special instructions outlined in the chapter "Handling and Charging of the Battery." Inappropriate use includes the use of the Product for stunts, jumps and/or riding with more than one person.
4. Overcharging the battery or not adhering to the Battery Care Instructions (whether provided with the sale or posted on the Super73 website), and any amendments thereto.
5. In the case of test, maintenance, repair, and replacement work due to normal use.
6. If the model, serial or product number on Super73 product has been changed, deleted, blurred, or removed. The seal and/or the serial number decal on the battery housing has been broken or obviously manipulated.
7. In the case of use of the battery in systems that are not approved for such use with this particular Product.
8. In the case of the operation of the Super73 system with batteries other than the batteries designed for the Super73 system (refer to owner's manual).
9. If one or more than one Super73 part has been opened, altered or repainted.
10. If Super73 concludes that there has been a case of modification or tampering with firmware.

II. If the Product is sold, gifted, or rented.

**LABOR COST OF REPAIRS:** Under Warranty, we will repair or replace defective components and parts only. This Warranty does not cover the required labor cost of repairs from non-authorized parties and Super73 reserves the right to withhold coverage of labor costs at its sole discretion.

### **Shipping Damage Claims**

IMMEDIATELY inspect your product(s) for damage. Freight damage claims are super time-sensitive. We will not accept shipping damage claims later than 10 days from receipt of the product. Note any damage to your product(s) on the Bill of Lading before you and the driver sign-off on the shipment. Take pictures of any damage that is found, and date the images when possible. Keep all packaging and paperwork until the inspection process is complete.

Whenever possible, report damage claims within 10 days of delivery to a Super73 customer service representative. Please contact our Technical Support department at [customercare-eu@super73.com](mailto:customercare-eu@super73.com) for return/replacement instructions.

**DISCLAIMER: THIS LIMITED WARRANTY SETS OUT THE FULL EXTENT OF SUPER73'S RESPONSIBILITIES, AND THE EXCLUSIVE REMEDY REGARDING THE PRODUCTS. ALL IMPLIED WARRANTIES, INCLUDING WITHOUT LIMITATION, IMPLIED WARRANTIES OF MERCHANTABILITY AND FITNESS FOR A PARTICULAR PURPOSE, ARE LIMITED TO THE DURATION OF THIS LIMITED WARRANTY. IN NO EVENT SHALL super73 BE LIABLE FOR DAMAGES ABOVE THE PURCHASE PRICE OF THE PRODUCT. SUPER73 MAKES NO WARRANTIES OR REPRESENTATIONS, EXPRESS OR IMPLIED, STATUTORY OR OTHERWISE, AS TO THE QUALITY, CAPABILITIES, OPERATIONS, PERFORMANCE OR SUITABILITY OF ANY THIRD PARTY SOFTWARE OR EQUIPMENT USED IN CONJUNCTION WITH THE PRODUCT, OR THE ABILITY TO INTEGRATE ANY SUCH SOFTWARE OR EQUIPMENT WITH THE PRODUCT, WHETHER SUCH THIRD-PARTY SOFTWARE OR EQUIPMENT IS INCLUDED WITH THE PRODUCT SOLD BY super73 OR OTHERWISE. SUPER73 IS NOT RESPONSIBLE FOR DIRECT, CONSEQUENTIAL OR INCIDENTAL DAMAGES, INCLUDING, WITHOUT LIMITATION, DAMAGES FOR PERSONAL INJURY, PROPERTY DAMAGE OR ECONOMIC LOSSES BASED ON CONTRACT, NEGLIGENCE, OR PRODUCT LIABILITY IN ALL STATES THAT ALLOW EXCLUSION OF LIMITATION OF DAMAGES. THIS WARRANTY GIVES YOU SPECIFIC LEGAL RIGHTS AND THOSE RIGHTS MAY VARY FROM PLACE TO PLACE. THIS WARRANTY DOES NOT AFFECT YOUR STATUTORY RIGHTS. WARRANTY DOES NOT COVER NORMAL WEAR AND TEAR, SHIPPING DAMAGE, UNAUTHORISED ALTERATIONS, MODIFICATIONS, ACCIDENTAL DAMAGE AND DAMAGE FROM MISUSE OR NEGLIGENCE.**

No agent, employee, dealer, representative or reseller is authorized to modify or extend this Limited Warranty or to make binding representations or claims, whether in advertising, presentations or otherwise, on behalf of SUPER73 regarding the Products or this Limited Warranty.

### **Return and Cancellation Policy**

1. If you purchased the bike and it hasn't shipped yet, we will issue a 100% refund.
2. If shipped, you have 14 days after delivery to do so. Your item must be packed in the original box and with the original protection material. The product should be free from dirt, dust - you may test ride a bike for example, but if the product has marks, damages or other indications of use or damaged cause by the return shipping, we have the right to deduct these costs from the refund. Please make sure the bike is fully protected.
3. We don't accept returns after 14 days from the delivery date.
4. We won't accept return on used items unless it falls under our limited warranty.
5. The buyer must pay for return shipping.

6. The buyer is responsible for the return shipment including possible shipping damages and lost shipments.
  7. Make sure you photograph and document the packaging before returning any item.
  8. We recommend insuring any return shipment for loss or damages.
  9. The customer must have written approval from a Super73 customer service rep before initiating a return.
  10. Once approved, we inspect your returned item and determine if it is an exchange, store credit, or a refund.
- II. **PR-EORDER CANCELLATIONS:** All pre-orders that are canceled prior to shipping are only eligible for a 100% refund of the total order price. Refunds may take up to 10 working days.