



Owners Manual

Submersible Light Kits

Models RGB3C5, RGB6C5



Contents

Important Safety. . . .	pg2
General Instructions. . . .	pg2
Parts Included. . . .	pg2
Assembly Instructions. . . .	pg3
Instructions For Mounting LED6125 and LED6C11. . . .	pg5
RGB control panel installation & operating instructions. . . .	pg6
Maintenance Recommendations. . . .	pg8
Warranty Policy. . . .	pg8
Troubleshooting Tips. . . .	pg10
RGB3C5 Replacement Parts. . . .	pg11
Repair Contact Form. . . .	pg12
Registration Information. . . .	pg16

Kasco Marine, Inc.
800 Deere Rd.
Prescott, WI 54021
PH (715) 262-4488
FAX (715) 262-4487
www.kascomarine.com

THANKS

We at Kasco Marine, Inc. would like to both thank and congratulate you on your purchase of the Submersible LED Light Kit. This kit will illuminate your fountain for a beautiful display. We thank you for choosing Kasco for your fountain and aeration needs and want you to be completely satisfied with your purchase.

Important Safety

Please read and follow these extremely important safety and handling instructions for your Kasco equipment. Following these instructions will help ensure your safety and the quality performance of your equipment.

- Under NO circumstances should anyone enter the water with the electrical equipment plugged in and/or in operation. All Kasco equipment is designed and built for use in water, and control panels are available with GFCI protection. However, it is NEVER recommended to enter the water with the equipment in operation.
- Kasco's Submersible Light Kits are intended for use with a Listed control panel having a GFCI protected receptacle, or field wiring terminals & disconnect switch, or a timer with a disconnect for use with a GFCI receptacle. They are intended to be mounted on a floating fountain or aerator for use in a natural or man-made body of water to comply with NEC Article 682.
- Kasco's Submersible Light Kits have not been evaluated for use in swimming pools, spas or stationary fountains.
- The power connection for the RGB light controller is 120Vac and MUST be plugged into a GFCI protected receptacle or GFCI protected field terminal connection.
- Caution should be used when dealing with any electrical and/or moving equipment.
- NEVER run the unit out of water. It could create a dangerous situation for the operator.
- Extreme caution should be used around water, especially cold water, as in Spring, Fall, and Winter, which poses a hazard itself.
- NEVER lift or drag the fountain or light kit by the power cords. If you need to pull the unit to the side of the pond, use the anchoring ropes.
- Do not use waders in ponds/lakes that are deep,

with drop-offs, drastic slopes, or soft bottom material.

- Do not use a canoe or boat that tips easily during installation
- To reduce the risk of electrical shock, be certain the light kit is connected to the GFCI protected lighting circuit of your control panel. For more information regarding your control panel instructions, refer to your fountain owner's manual or download control panel wiring diagrams from <https://kascomarine.com/resources/downloads/instruction-operating-manuals/>
- A control panel must be installed a minimum of 5 feet (3m in Canada) from the body of water unless separated from the body of water by a fence, wall, or other permanent barrier that will make the unit inaccessible to persons in the water.

General Instructions

INSPECT THE SHIPMENT

Immediately inspect this shipment for any visible damages. Also cross reference the "Parts Included" section to check for part shortages. Shortages should be reported immediately to your Kasco Marine distributor or representative and damages reported to your carrier and Kasco Marine.

Parts Included

RGB3C5

- A. Light Kit cord with waterproof connectors (1)
 - B. Sealed LED light fixtures with flex sleeve (3)
 - C. 1/4" x 1 3/8" Stainless Steel Bolts (3)
 - D. 1/4" Stainless Steel Flat Washer (3)
 - E. 1/4" Stainless Steel Lock Washer (3)
 - F. 1/4" Stainless Steel Nut (3)
 - G. Nylon Cable Ties (9)
 - H. Stainless steel mounting brackets & hardware (3)
 - I. Sealing cap (3)
 - J. 4" spacer washers (3)
 - K. 1/4" x 5" Stainless Steel Bolts (3)
 - L. Spare Oring (1)
 - M. RGB control box with remote control
- Note: Extra hardware may be included. One extra spare oring is included.

RGB6C5

- A. Includes two (2) sets of RGB3C5(see parts

included in RGB3C5

- B. Lower float brackets (6)
- C. 3/8" washers (3)

TOOLS & SUPPLIES NEEDED

- A. Two 7/16" Wrenches (or one wrench & a 7/16 socket with driver)
- B. Diagonal Pliers or Cutter for Nylon Zip Ties
- C. Small flat blade screwdriver for wire terminals

Assembly Instructions

For ease of assembly, make sure the Aerating Fountain is completely assembled. Place the assembly upright.

1. Install the mounting brackets to the light fixtures by fitting the head of the #10 screw into the tabs on each side of the fixture. Place one O-ring then lock washer on each #10 screw then tighten the thumb screws on each side hand tight only.

Fig 1

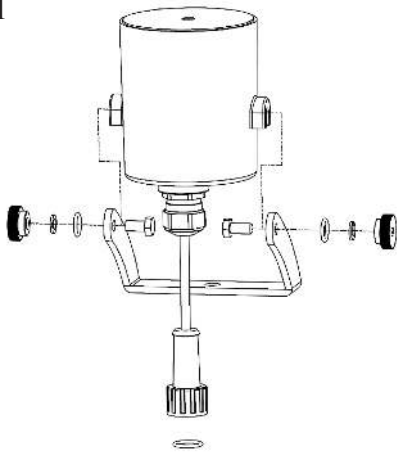

**Instructions for mounting lights on model:
2400VFX, 3400VFX, 3400HVFX, 3400J, 3400HJ,
4400VFX, 4400HVFX, 4400J, 4400HJ**

2. Insert the 1/4" x 1-3/8" bolt into the light fixture bracket. Align the light fixture bracket to the float tab by placing the bolt through the light mounting hole (light fixture bracket is on top of the float tab) as shown in Figure 4.



Fig 4

3. Install the 1/4" Flat Washer, 1/4" Lock Washer and 1/4" Nut against the underside of the float tab as shown in Figure 5. Tighten the nut until snug using the 7/16" Wrench.

Fig 5



4. Adjust the angle of the light as desired and tighten the two brass thumb screws on the sides of the fixture until snug. Do not over tighten. It is best to have all three fixtures at the same angle.
5. Repeat steps 1 through 4 for the remaining fixtures. Assembled light fixtures are pictured in Figure 6. Note the orientation of the lights.

Fig 6

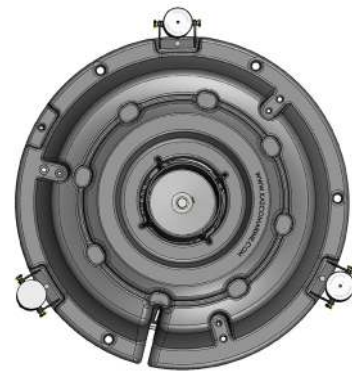

6. Connect each fixture cord to the power cord's waterproof connectors.

Make sure the orange or black oring is installed on the plug side of the waterproof connector. If any are missing, check the packaging to see if any fell off during shipping, or an extra oring was included if there is one missing.

Hand tighten the waterproof connectors as shown in Figure 7. Using a cable tie, tie the light kit power cord to the float opposite the fountain power cord. This will keep the cord from being damaged by the fountain and balance the unit properly.

Next, cable tie each fixture cord to the float to protect each fixture cord as shown in Figure 8.

Fig 7 Check for orange or black oring



Fig 8



7. Upon installation of the assembled unit, connect your LED light kit to your field installed GFCI protected outlet and timer.

Note:

Installation of these LED light fixtures on the above listed aerator/fountain units will ensure proper submersion of the light fixtures. Each fixture must be partially submerged in order for lights to operate properly. Other applications for these fixtures must provide at least the same submersion to properly cool the fixture. Operating the fixtures out of water will damage the LED and void warranty.

A sealing cap is provided for field removal of one light fixture. If a fixture fails to operate it can be removed and the cap installed onto the waterproof connector of the power cord. This will allow you to continue to operate your light kit with two fixtures while a replacement fixture is procured.

Instructions for mounting lights on model: 8400VFX, 8400JF, 2.3VFX, 2.3JF, 3.1JF, 3.3JF, 5.1JF, 5.3JF, 5.1VFX, 5.3VFX, 7.3JF

2. Insert the 1/4" x 5" bolt into the light bracket and extension as shown in Figure 9. Place this assembly on the float bracket

Fig 9



3. Install the 1/4" Flat Washer, 1/4" Lock Washer and 1/4" Nut as shown in Figure 10. Tighten the nut until snug using the 7/16" Wrench.

Fig 10

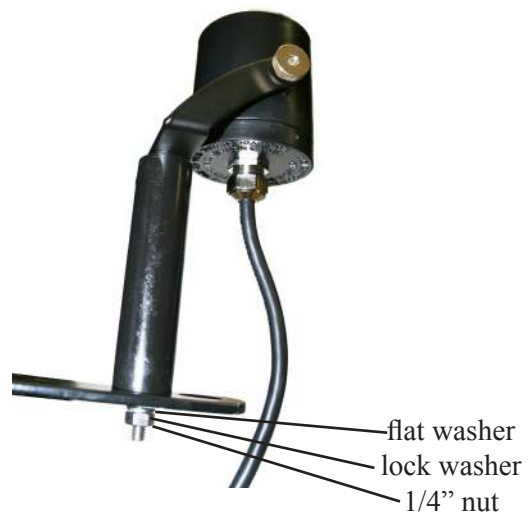

4. Adjust the angle of the light as desired and tighten the two brass thumb screws on the sides of the fixture until snug. Do not over tighten. It is best to have all three fixtures at the same angle.

5. Repeat steps 1 through 4 for the remaining fixtures. Assembled light fixtures are pictured in Figure 4. Note the orientation of the lights.

6. Connect each fixture cord to the power cord's

waterproof connectors.

Make sure the orange or black oring is installed on the plug side of the waterproof connector. If any are missing, check the packaging to see if any fell off during shipping, or an extra oring was included if there is one missing.

Hand tighten the waterproof connectors as shown in Figure 11. Using a cable tie, tie the light kit power cord to the float opposite the fountain power cord. This will keep the cord from being damaged by the fountain and balance the unit properly.

Next, cable tie each fixture cord to the float to protect each fixture cord as shown in Figure 12.

Fig 11 Check for orange or black oring



Fig 12



7. Upon installation of the assembled unit, connect your LED light kit to your field installed GFCI protected outlet and timer.

Instructions For Mounting LED6125 and LED6C11

Instructions for attaching brackets on the float prior to mounting the light fixtures on 2 HP or larger Kasco units.

Parts needed:

- Lower float brackets (6)
- 3/8" washers (3)



Part 1



Part 2

1. Turn the unit upside down. Loosen and remove the 3/8" nuts on the three 9" bolts that are closest to the motor unit. Place 2 Lower Float Brackets(Part #1) and one 3/8" washer(Part #2) on each of the 9" bolts over the bottom screen clips and replace the 3/8" nut.



2. Arrange the brackets into the position shown and tighten down the nuts. Once the brackets are secure, turn the unit back into its upright position.

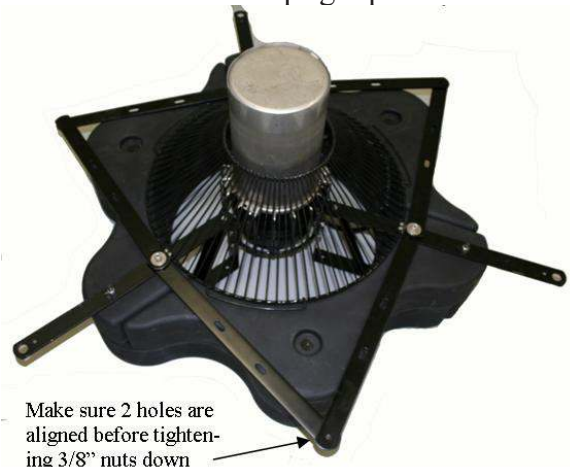

3. Follow the instruction on the previous page (LED3125 Assembly instructions) to mount the light kit to the brackets.

RGB control panel installation & operating instructions

Important Safety:

Please read and follow these important safety and handling instructions for your Kasco equipment. Following these instructions will help ensure your safety and the quality performance of your equipment.

- Under NO circumstances should anyone enter the water with the electrical equipment plugged in and/or in operation. All Kasco equipment is designed and built for use in water, and fountain control panels are available with GFCI protection. However, it is NEVER recommended to enter the water with the equipment in operation.
- Kasco's Submersible Light Kits are intended for use with a Listed control panel having a GFCI protected receptacle, or field wiring terminals & disconnect switch, or a timer with disconnect
- for use with a GFCI receptacle. They are intended to be mounted on a floating fountain or aerator
- for use in a natural or man-made body of water to comply with NEC Article 682.
- Kasco's Submersible Light Kits have not been evaluated for use in swimming pools, spas or stationary fountains.
- The power connection for the RGB light controller is 120Vac and MUST be plugged into a GFCI protected receptacle or GFCI protected field terminal connection.
- Caution should be used when dealing with any electrical and/or moving equipment.
- NEVER run the unit out of water. It could create a dangerous situation for the operator.

Refer to your fountain/Aerator owner's manual for complete installation, operation and safety instructions for your installation.

Inspect the control panel for any damage. Report damage to your distributor or Kasco.

Installation:

1. Open the control box and remove the operating instruction sheet, Remote control, and battery. Insert the battery into the remote control. If the battery is already inserted, remove the plastic

battery guard from the remote to activate the battery connection.

2. The RGB control box is ready to mount next to your Kasco C-25, C-85, C-95 or 3phase fountain control box. (Mount a minimum of 5ft from water). Using two exterior grade wood screws: one for the top and one for the bottom hanger. The RGB control will hang from the screws. You only need to tighten the top screw to prevent the box from lifting off the screws. Mount close enough to plug the power cord into your Kasco C-25 panel.

NOTE: DO NOT PLUG IN AT THIS TIME!

3. Once mounted, you are ready to connect the RGB light kit power cord to the field terminal connections in the RGB control box.

Connect:

White to white

Green to Green

Red to Red

Black to Black

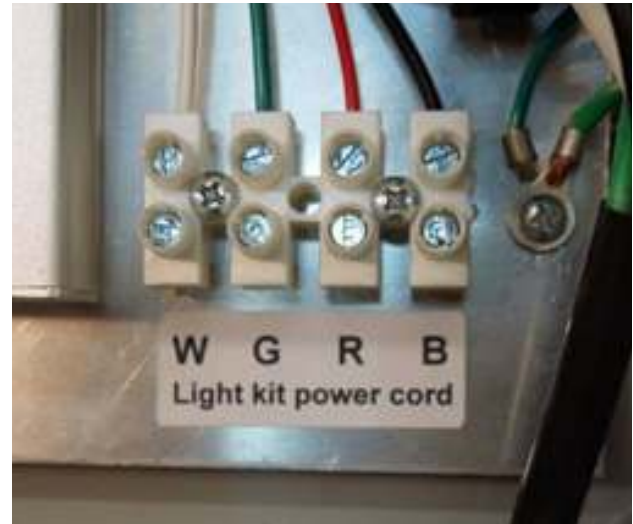

Connect light kit power cord wires to this terminal block.

4. The control box is now ready to plug into your Kasco C-25 fountain control box. Plug into the Light receptacle in the C-25. This will allow the C-25 to control the lights with the fountain. To energize the C-25 light receptacle you will need to cover the photo-eye of the C-25. Refer to your C-25 instructions.

If you have a Kasco C-85, C-95 or 3phase control panel, you will need to hardwire the RGB controller power cord to the light terminals in your fountain control panel. Refer to your fountain owner's manual for connection information.

The Kasco C-85, C-95, and 3phase control panels use a timer for controlling the light output. Ensure the light timer is set as required. Refer to your fountain owner’s manual for timer setting instructions.

5. Now, the light kit is ready for operation. With the RGB controller door open you will see a red LED “Power” indicator on the RGB control module. If this indicator is not on, then power is not being sent to the RGB control box. Check that the C-25 is energizing the light receptacle.

6. Once you verify power to the RGB control box. You are ready to test the lights for functionality. The following steps explain how to use the remote control to change function of the RGB lights.

Operating your RGB control with remote

1. The RGB controller is operated with the included remote control. The controller will operate in the last mode set until it is changed with the remote control.

2. Figure 1 details the remote control’s Button functions. The Green signal indicator (on the RGB controller) will flash while the remote is communicating to the controller.



Fig.1

Button function:

1: Power On/Off. Press the button once to turn on, again to turn off. The controller will remain off if turned off with the remote. Turning the controller on with the remote will allow the fountain control box to control the lights.

2: 9 static color modes. White, Red, Green, Blue, warm white, Amber, yellow, cyan, magenta. Pressing the desired color will set the RGB controller output to that color and will remain on that color. Repeatedly pressing the color will dim the color from: 100%, 50%, 25%, 12%, 6% and cycle back to 100%.

3: Automatic sequencing modes: Selecting one of these modes will automatically sequence the colors in one of three modes:

- Flash – jump to next color (7 colors)
- Bloom- transition from color to color (3colors)
- Smooth – smooth transition from color to color (7 colors)

4: S+, S- button slow down or speed up the automatic sequencing of the 3 automatic modes.

5: Music input control

The RGB controller is capable of changing colors based on sound input. The controller has a 3.5mm audio jack, and a microphone built into the controller. The microphone input is adjustable with a level sensitivity dial.



The remote control has 3 automatic music modes:

- FT – Fast track, color change is fast change
- MT – My track, color change is medium
- Changing speed
- CT – Cool track, color change is slower and smoother than FT, and MT.

The Audio input jack is compatible with your headphone jack on a smartphone, MP3 player, or a pre-amp type output. Do not connect to a line level (amplified speaker) output.

A 3.5mm Y adapter will allow you to connect your

audio source to the RGB controller and your stereo amplifier simultaneously if desired.

Maintenance Recommendations

- Under No Circumstances should anyone enter the water while a fountain is operating.
- Please keep the original box for maintenance shipping.

The following maintenance procedures can be utilized to ensure many years of quality performance from your Kasco Fountain and Light Kit and reduce the need for more costly repair work.

PROPER INSTALLATION: Proper installation of Kasco equipment will include a power source with ground fault protection. For Fountain models, Kasco provided control panels included with the unit have built-in ground fault protection. Ground fault interrupters are a safety feature that

can also alert you to electrical leaks in the equipment. If you have repeat, consistent trips of the ground fault device, the equipment should be disconnected and removed from the water. The power cord should be inspected for damage and you should contact your distributor, or call Kasco Marine at 715-262-4488 for further instructions or email Kasco at sales@kascomarine.com.

OBSERVATION: Operating equipment should be observed on a regular basis (daily, if possible) for any reduction or variation in performance. If a change in performance is observed, the equipment should be disconnected from power and inspected.

WINTER STORAGE: In regions where there is significant freezing in the wintertime, the fountain and light kit should be removed from the water to protect them from the expansion pressure of the ice. In many areas, fountains will keep some amount of ice open through the winter. However, when the water is thrust into the air, it is exposed to the colder air temperatures longer and can actually make ice thicker on the pond/lake. Storage over winter is best in a location that is out of the sun and cool, but above 32° F.

CLEANING: Fountains and light kits should be removed from the water at least once per year (at the end of the season in cold climates) to clean the exterior of the system, especially the stainless steel motor housing (can) and light fixtures. The motor housing and light fixture surfaces dissipate heat into the water and any algae, calcium, etc. build-up will become an insulator that blocks heat transfer. In warmer regions, it is recommended that the motor is removed and cleaned at least two to three times per year

depending on conditions. In most cases a power washer will be sufficient if the unit and algae are still wet. Also, make sure the lens of the light fixtures is clean to ensure the brightest light possible.

FIXTURE REPLACEMENT: The LED light fixtures are sealed and do not require any maintenance other than cleaning. If a fixture fails to operate it can be removed and the sealing cap installed onto the waterproof connector of the power cord. This will allow you to continue to operate your light kit with two fixtures while a replacement fixture is procured. Only perform this removal/replacement with all equipment disconnected from the power source.

Any required repairs need to be performed by Kasco Marine. Any alterations or changes made to Kasco units by an unauthorized source will void the warranty. This includes tampering with the unit, power cord, and/or control box.

Please contact Kasco Marine, Inc. at 715-262-4488 or sales@kascomarine.com.

Warranty Policy

Warranty period:

RGB3C5 and RGB6C5 = 2 year

Limited Warranty: Kasco® Marine, Inc. warrants this Light Kit to be free from defects in material or workmanship under normal use and service. The Kasco Marine, Inc. obligation under this warranty is limited to replacing or repairing free of charge any defective part within the warranty period from the date of shipment. Customer shall pay shipping charges for returning the unit to Kasco.

THIS WARRANTY IS IN LIEU OF ANY OTHER WARRANTIES, EXPRESSED OR IMPLIED, AND ANY OTHER OBLIGATION OR LIABILITY WHATEVER ON THE PART OF KASCO MARINE, INC. AND IN NO EVENT, SHALL KASCO MARINE, INC. BE LIABLE FOR ANY SPECIAL OR CONSEQUENTIAL DAMAGES.

Warranty is void if:

The Light Kit is not maintained properly according to the Maintenance Recommendations supplied in this Owner's Manual.

The lights, control box, or power cord are altered in

any way from original shipment. Cuts in the power cord are not covered under warranty.

The Light Kit is damaged by unauthorized tampering.

Warranty Claim Procedure:

The warranty coverage can be established by the date of purchase receipt or by calling Kasco Marine, Inc. Please call Kasco Marine at 715-262-4488 prior to shipping to receive a Return Authorization Number and/or Repair Form, then ship to:

Kasco Marine, Inc. 800 Deere Rd.

Prescott, WI 54021 Attn: Repairs

You can also email Kasco at sales@kascomarine.com.

Note: Please contact Kasco to determine if the main power cord needs to be returned to be considered for warranty. The power cord may be needed to diagnose the failure.

Please include the Repair Form received from Kasco Marine or your local distributor with the shipment. If no Repair Form is available, include your name and physical address for return delivery of the repaired Light Kit and a daytime phone number and/or e-mail address for correspondence regarding the warranty claim.

Any expedited shipping method for the return of the unit is at the customer's expense. Kasco Marine will return units repaired under warranty at our expense via ground freight

Non-Warranty Repairs:

Most failed equipment can be repaired at substantially lower costs than replacement with new. If your light kit requires repair and is no longer covered under warranty, please contact Kasco Marine for current repair pricing. Please ship according to the instructions in the previous section. Again, it is best to call ahead for a Return Authorization Number and/or Repair Form so we know the repair is coming.

All light kits that are rejected for repair will be destroyed unless otherwise directed by the customer. If the customer would like the Light Kit returned, it will be restored as closely as possible to the condition in which it was received and shipped at the customer's expense for shipping and handling charges.

Billing:

All non-warranty repairs will be returned to the

customer and billed C.O.D. unless otherwise directed. Kasco Marine also accepts Visa and MasterCard credit card payments. Kasco Marine will call for credit card information upon completion of the estimate at the customer's request.

All other warranty and repair inquiries should be directed to Kasco Marine, Inc. at 715-262-4488 or sales@kascomarine.com.

Troubleshooting tips -

The following is provided to help diagnose a probable source of trouble. It is a guideline only and may not show all causes for all problems. For additional troubleshooting help contact your local distributor or visit www.kascomarine.com for additional help.

NOTE: you may need to refer to your owners manual that was provided with your fountain for additional control panel settings and adjustments.

Problem	Possible Cause	Likely Remedy
Light kit is installed and wired, but will not turn on.	Power is off or disconnected	Ensure control panel is connected to the electrical circuit. Verify circuit breakers, timers, and/or interlock switches are turned on and functional. Refer to your owner's manual that was provided with the fountain to check fountain control panel is operating properly.
	Not dark enough for photo eye to activate	C-25 control panel: The control panel has a photo eye on the left side of the enclosure exterior. This photo eye measures ambient light. To activate, the photo eye must not measure any ambient light for at least several minutes. Also, the C-25 timer must be turned on (fountain operating) to allow the light circuit to energize. Covering the photo eye with black electrical tape will activate the photo eye for testing.
		C-85, or C-95 control panel with GFCI outlet and photo eye control: The control panel has a photo eye on the left side of the enclosure exterior. This photo eye measures ambient light. To activate, the photo eye must not measure any ambient light for at least several minutes. Also, the fountain timer must be turned on (fountain operating) to allow the light circuit to energize. Covering the photo eye with black electrical tape will activate the photo eye for testing. While the photo eye is covered, the GFCI outlet can be reset if tripped.
	Timer not set properly	C-85, or C-95 control panel (and all 3phase fountain control panels) with terminal connections and timer control for light kit: The control panel has a second timer for controlling the lights (No photo eye). Ensure the light timer is set to operate the lights. The timer has a built in Hand-Off-Auto switch. Ensure the switch is set properly. Ensure the fountain is turned on. The light timer will not energize the light kit unless the fountain circuit is energized.
GFCI is tripped	GFCI is tripped	C-25 control panel: Reset the GFCI. If the GFCI does not reset it could be a ground fault in the fountain wiring, or the light kit wiring. Unplug both the fountain and light kit and reset the GFCI. If it resets, plug fountain then light kit back in and see which one trips the GFCI. If the GFCI does not reset with both unplugged, then the GFCI may be defective.
		C-85, or C-95 control panel with GFCI outlet and photo eye control: To reset the GFCI outlet the fountain timer must be turned on, and the photo eye must be activated. (black electrical tape can be wrapped around the photo eye to activate it). Once these are on, the GFCI reset button can be pressed. (unplug the light kit prior). Plug the light kit in and see if it operates. If the GFCI trips again then the light kit may be damaged. If the GFCI does not reset (with light kit unplugged) then it may be defective or the photo eye is not activated to send power to the outlet.
		C-85, or C-95 control panel with terminal connections and timer control for light kit: For panels with a GFCB (ground fault circuit breaker) and timer controlled lights, simply reset the two pole breaker. This will turn the fountain and light kit back on if the timers are set to on! If it trips again, disconnect the light kit from the terminals and reset. WARNING! you must turn off power to the panel before disconnecting any wiring from the terminals! If the breaker trips with the light kit disconnected, then disconnect the fountain as well and reset. If the breaker continues to trip it may be a defective GFCB. If the breaker resets, then reconnect the fountain then the light kit to see which one trips the GFCB.
Lights work. However, they are not as bright as when first installed	Dirty lenses	3phase fountain control panels: 3phase fountain panels have a ground fault sensing module that will trip if either the light kit or fountain has a ground fault. To reset the module, simply press the reset button in the panel. This will turn the fountain and light kit back on if the timers are set to on! If it trips again, disconnect the light kit from the terminals and reset. WARNING! you must turn off power to the panel before disconnecting any wiring from the terminals! If the GFI module trips with the light kit disconnected, then disconnect the fountain as well and reset. If the GFI module continues to trip it may be a defective module or an internal wiring issue with the panel. If the module resets, then reconnect the fountain then the light kit to see which one trips the module.
		Turn of power to the control panel and disconnect power cords to the fountain and the light kit. Bring the fountain to the shore and inspect the light lenses. Over time, algae growth and hard water deposits on the lenses can block light output. Clean the lenses with a soft brush and the light should be bright again.

ITEM NO.	PART NUMBER	DESCRIPTION	QTY.
1	347000	ASSEMBLY, RGB LIGHT	1
2	345042	SCREW, 10-32 x 1/2	2
3	771037	WASHER, #10 SPLIT LOCK	2
4	345043	10-32 THUMB NUT	2
5	345007	BRACKET	1
6	345035	O-RING, LED CORD CONNECTOR	1
7	584692	1/4-20 X 1-3/8" BOLT	1
8	258476	FLAT WASHER, 1/4"	1
9	840537	LOCK WASHER, 1/4"	1
10	840536	NUT, 1/4-20	1
11	345046	SCREW, 1/4-20 X 5", HEX HEAD	1
12	345047	SPACER, ROUND, 4INCH	1
13	345008	ORING, C11 LIGHT BRACKET	2

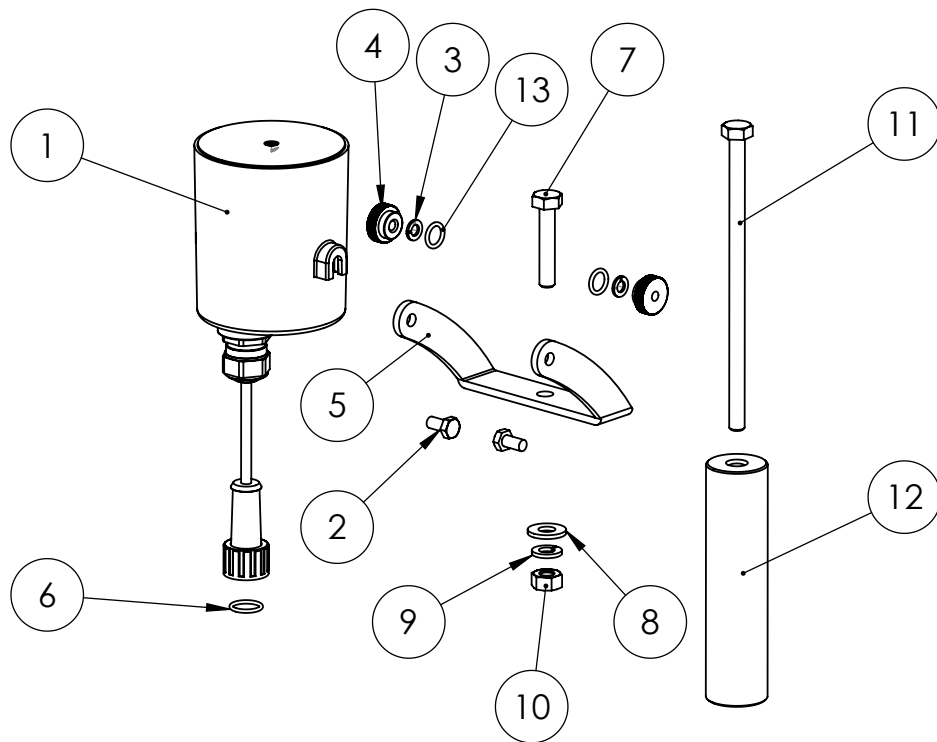

**ITEMS 7-10 REQUIRED FOR SMALL
FLOAT MOUNTING (1/2HP-1HP)**

**ITEMS 8-12 REQUIRED FOR LARGE
FLOAT MOUNTING (2HP * LARGER)**

REPLACEMENT PARTS FOR MODELS: RGB3C5, RGB6C5





800 Deere Rd
 Prescott, WI 54021
 Phone: 715-262-4488 Fax: 715-262-4487
www.Kascomarine.com Sales@kascomarine.com

Repair Contact Form

- ❖ **Kasco requires all Repairs sent in MUST be accompanied by this form and marked to Repairs attention. (ex. Attn: Repairs)**
- ❖ **Repairs returned should include upper pump housing or wire basket for Aerators and De-Icers. These parts protect the motor during shipping.**
- ❖ **Kasco is NOT responsible for shipping damage accrued in return shipment.**
- ❖ **It is the responsibility of customer to ship and pay freight to Kasco.**
- ❖ **Do not ship float or control panel with unit, unless otherwise instructed**
- ❖ **A fee of \$60 per hour will be assessed for cleaning excessively dirty units and float disassembly**
- ❖ **Refer to the Owner’s manual for easy-to-follow troubleshooting rule out site issue.**

Note: Contact Information Should be that of the person or company to contact for repair.

Company	First Name	Last Name
Address	City	State
Zip code	Phone #	Alternate Phone #
Email Address	Preferred method of contact (Circle) Phone Email	Purchase order #

Submersible Pump Information (Complete if sending unit)	Light kit Information (complete if sending lights)	Parts Included (For office use)
Model #	Model #	Unit <input type="checkbox"/>
Serial #	Serial #	Cord <input type="checkbox"/>
Cord Length:	Cord Length:	Light Kit <input type="checkbox"/>
Purchased from:	Purchased From	Float <input type="checkbox"/>
Purchase Date:	Purchase Date:	Control Panel <input type="checkbox"/>

Additional notes for technician.

Registration Information

Fill in the information below and keep for your records.

Model # (Ex. RGB3C5) _____

Serial # (Ex. 2101LEDA3001) _____

Purchase Date: _____

Purchased From: _____

Registration Date: _____



Kasco Marine, Inc.
800 Deere Rd.
Prescott, WI 54021

Phone (715) 262-4488 • Fax (715) 262-4487

www.kascomarine.com • sales@kascomarine.com