

ENERGY DESK ASSEMBLY GUIDE



Tools Required:



Battery Drill



No#2 Phillips Driver Tip



No#2 Square Driver Tip



Soft Hammer



Desk Option :

Page Number :

Image :

Single Desk

3

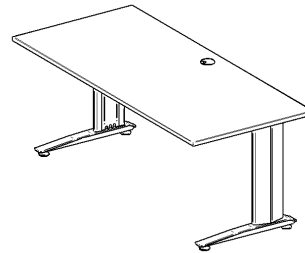

Single Desk With
18mm Modesty Panel

4-5

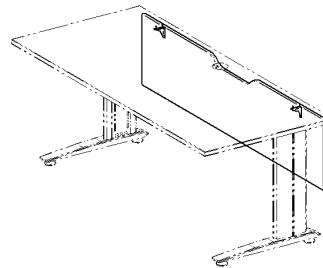

Inline 2 Pod

6

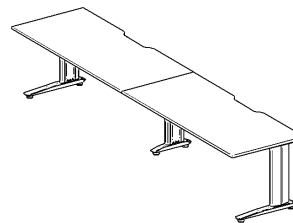

Corner Workstation

7

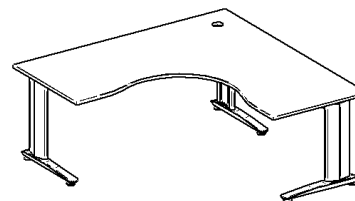

120Degree Corner Desk

8-9

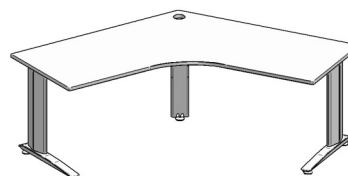

Single Desk

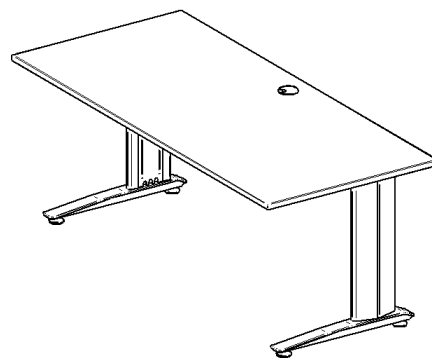

Parts list:



Bolt A (QTY:12)



Bolt B (QTY:12)

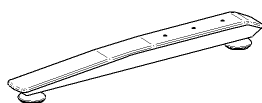

Foot (QTY:2)

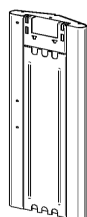

Leg Column (QTY:2)



Leg Top Plate (QTY:2)

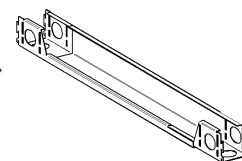

Extendable Beam (QTY:1)

Includes 4 wood screws and 4 bolts per beam

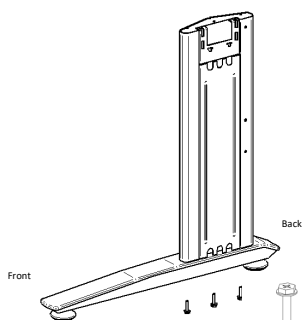

STEP 1: Attach Leg column to Foot, using bolt A. Make sure the bolt holes on the leg column are to the back of the foot as per above.

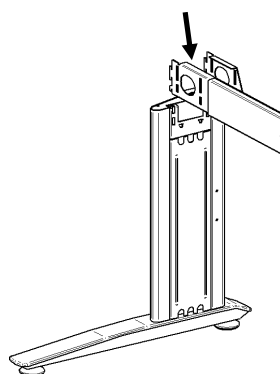

STEP 2: Attach the Extendable beam to the leg column as per above, having the open side of the beam to the front on a single desk makes it easier for the desk

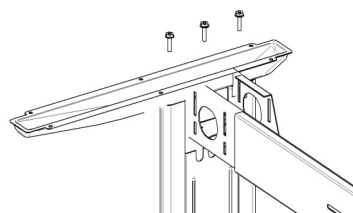
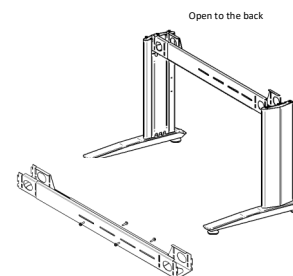
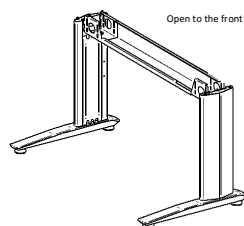

STEP 3: Attach the top plates to the leg columns using bolt A.

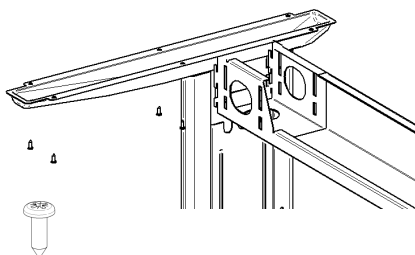

STEP 4: Place Desk top on the base frame, Attach the desk top to the frame with bolt B .

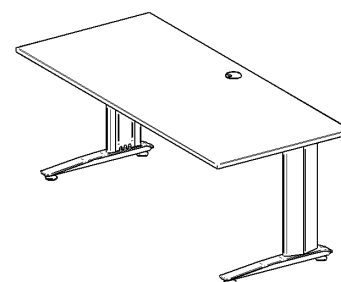

Energy 180 Degree Straight



18mm Modestly Panel

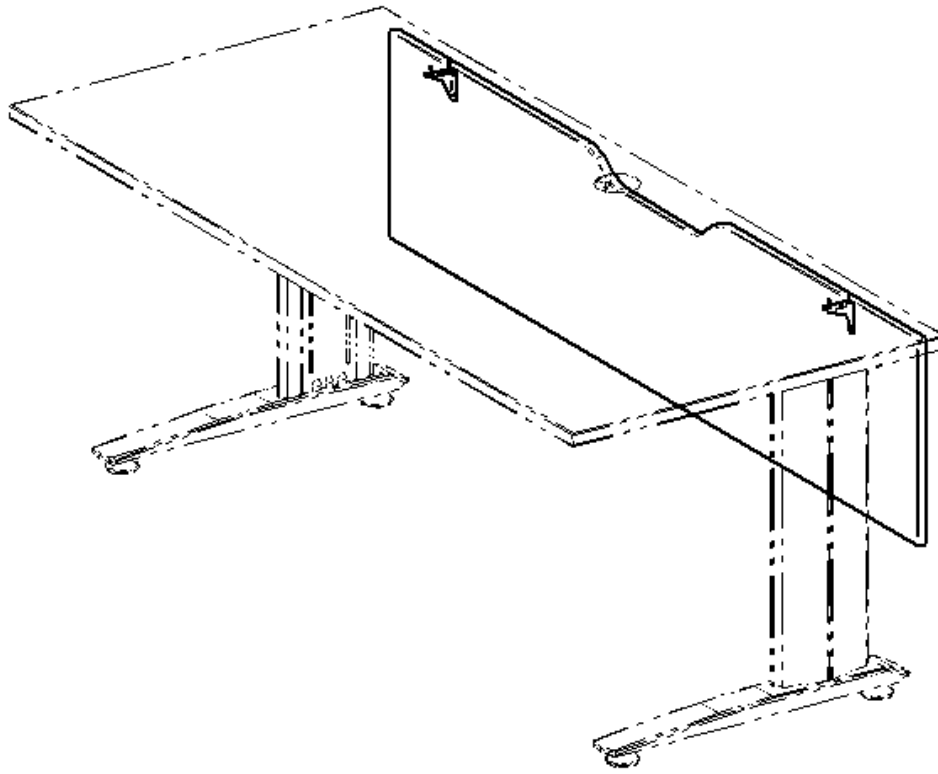

Parts list:

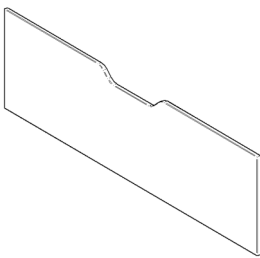

1 x 18mm Panel

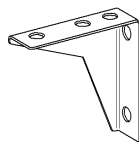

2 x Angle Brackets

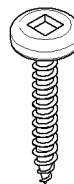

4 x Large Wood Screw (10g x 19mm)



4 x Small Wood Screw (8g x 16mm)



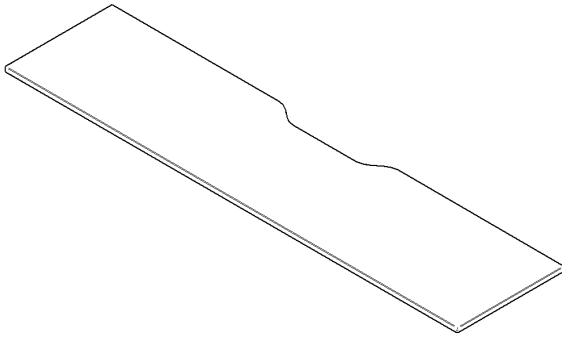

STEP 1: Place the modesty panel on a clean flat surface.

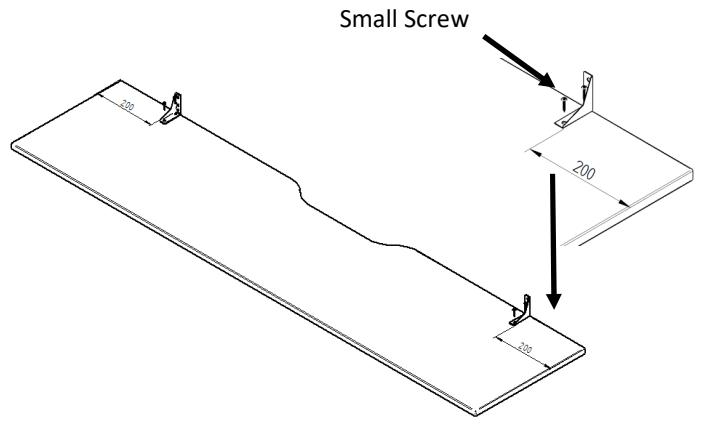

STEP 2: Attached the Brackets to the panel, using the Small Wood Screws (8g x 16mm)

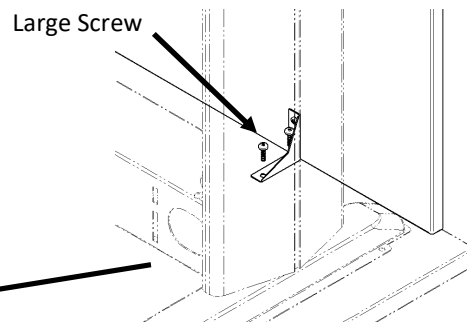
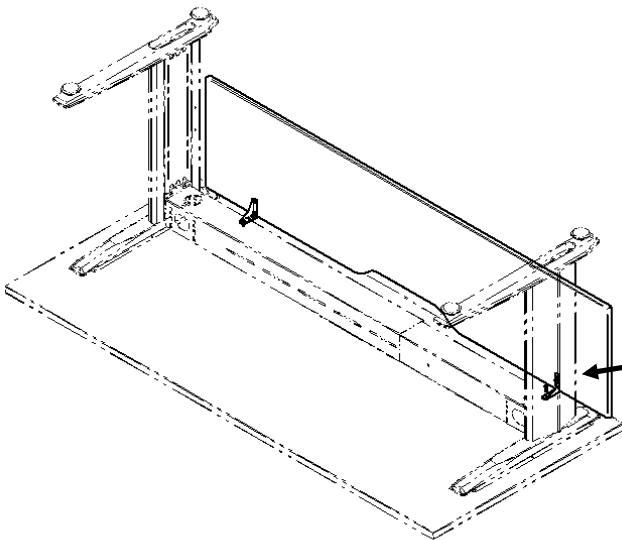

STEP 3: With the desk upside down attach the panel to back edge, using the large wood screws (10g x 19mm)

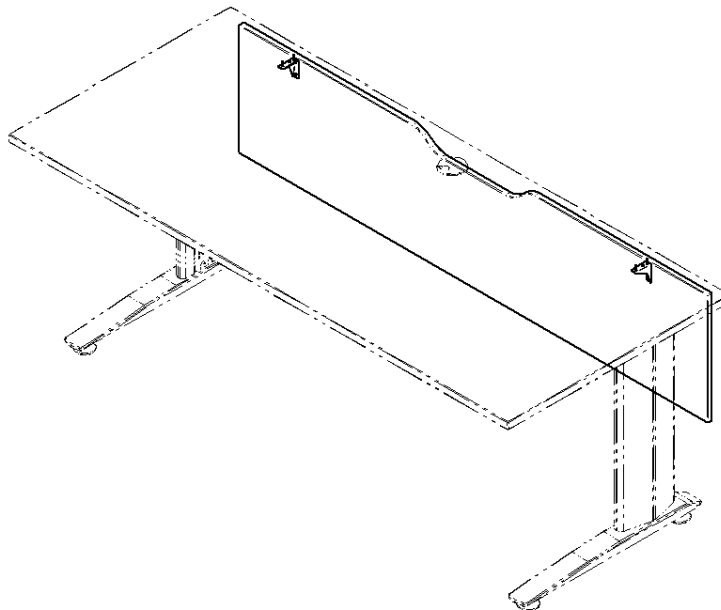

Inline 2 Person

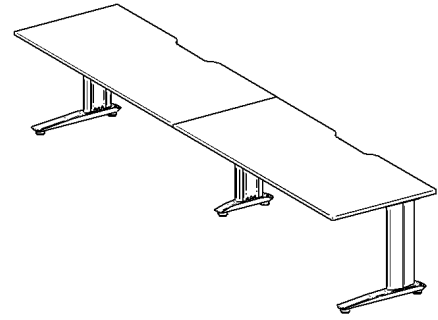

Parts list: (Part quantity's may vary depending on table configuration)

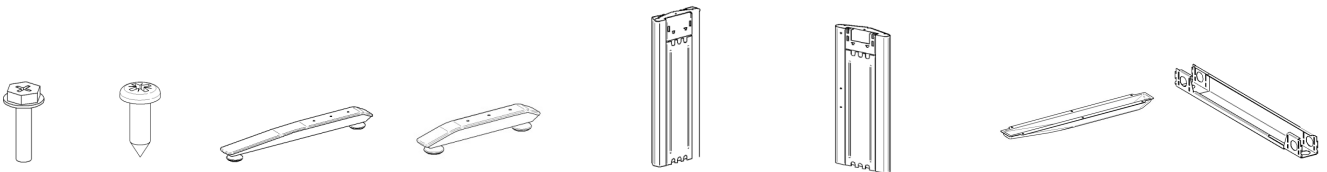

Bolt A (QTY: 18) Bolt B (QTY:18) Large Foot (QTY:2) Small Foot (QTY: 1) Inline Leg Column double sided (QTY:1) Leg Column /RH (QTY: 2) Leg Top Plate (QTY: 3) Extendable Beam (QTY:2)

Includes 4 wood screws and 4 bolts per beam

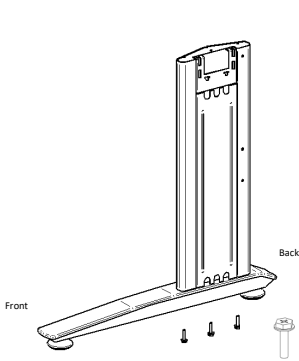

STEP 1: Attach Leg column to Foot, using bolt A. Make sure the bolt holes on the leg column are to the back of the foot as per above.

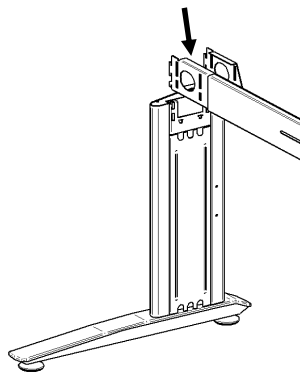

STEP 2: Attach the Extendable beam to the leg column as per above. Note: The beam can be installed with the open side to either the front or back, depending on the preference of the user. Use a nylon hammer to hit the top of the beam into place. Using the bolts supplied with the beam, Install 2 bolts front and back of each beam as per above.

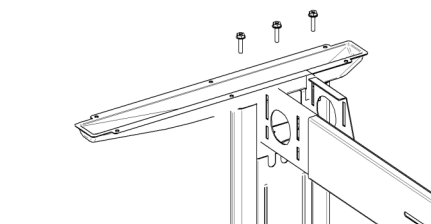

STEP 3: Attach Leg top plate to the top of the Leg columns using bolt A.

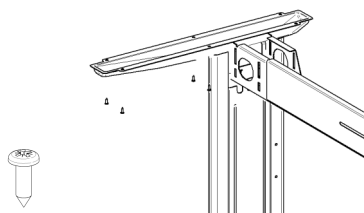

STEP 4: Place Desk top on the base frame, Attach the desk top to the frame with bolt B .

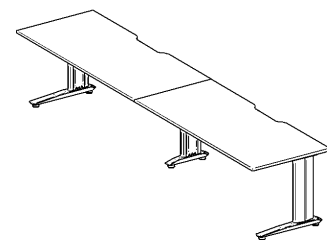

ENERGY 2Pod Inline



Corner Workstation

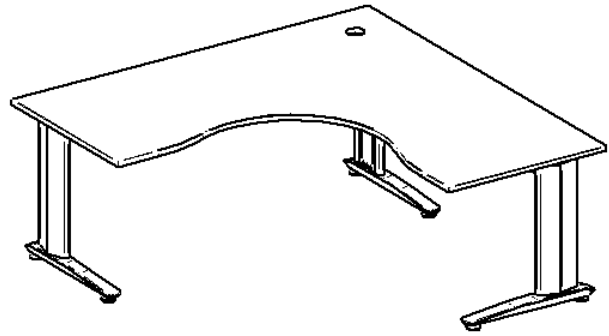

Parts list:

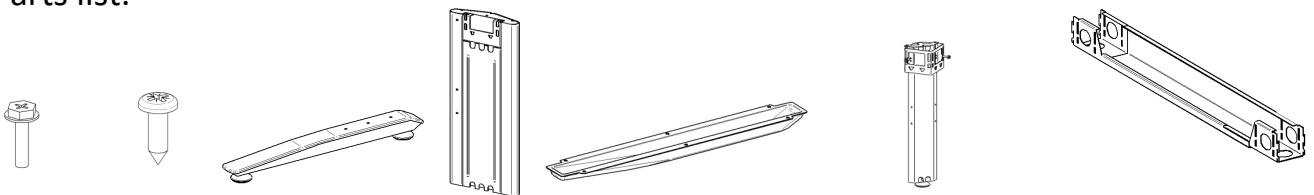

Bolt A (QTY: 18) Bolt B (QTY:18) Foot (QTY:3) Leg Column (QTY:3) Leg Top Plate (QTY: 3) Option : 90degree Back corner leg Extendable Beam (QTY:2)

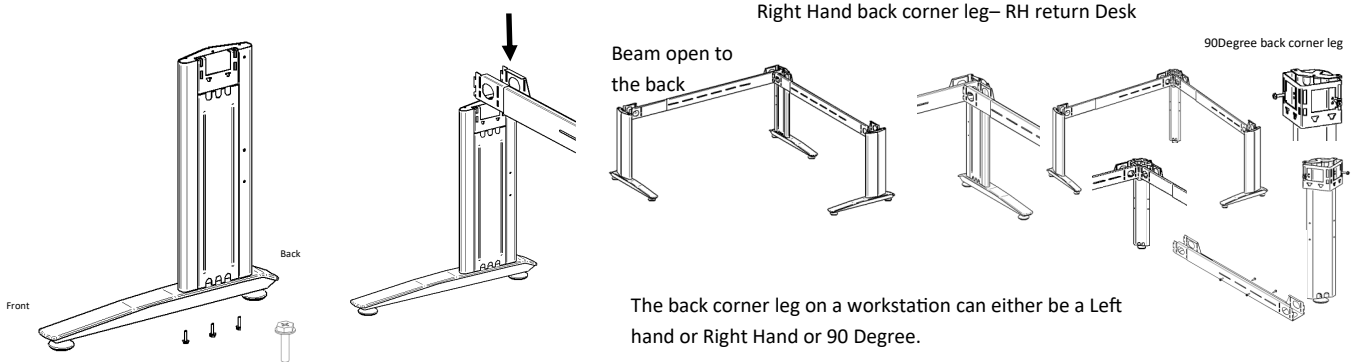

STEP 1: Attach Leg column to Foot, using bolt A. Make sure the bolt holes on the leg column are to the back of the foot as per above.

STEP 2: Attach the Extendable beam to the leg column as per above. Note: The beam can be installed with the open side either the front or the back, depending on the preference of the user. Use a nylon hammer to hit the top of the beam into place. Using the bolts supplied with the beam, Install 2 bolts front and back of each beam as per above.

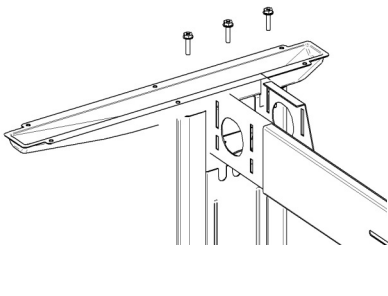

STEP 3: Attach Leg top plate to the top of the Leg column using bolt A.

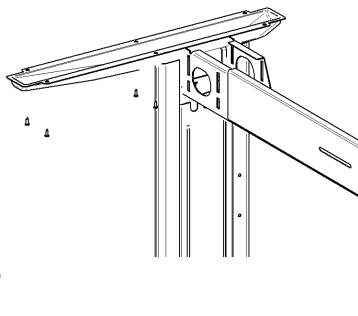

STEP 4: Place Desk top on the base frame, Attach the desk top to the frame with bolt B .

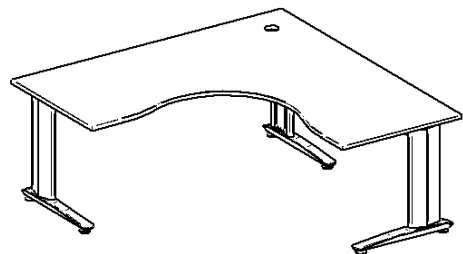

Finished Product ENERGY Corner Workstation



120Degree Single Desk

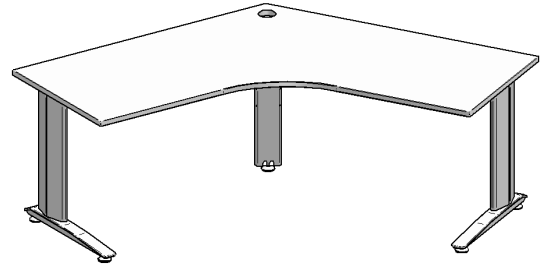

Parts list:



Bolt A (QTY:12)



Bolt B (QTY:12)

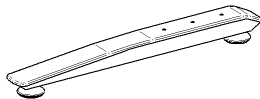

Foot (QTY:2)



Leg Column (QTY:2)

1x LH, 1 x RH

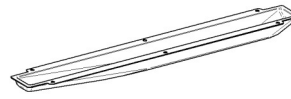

Leg Top Plate (QTY:2)

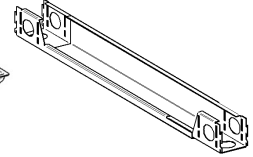

Extendable Beam (QTY:2)

Includes 4 wood screws and 4 bolts per beam

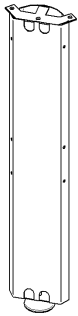

Corner pole leg (QTY:1)

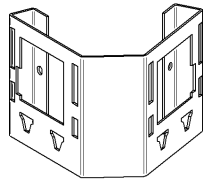

120 degree corner bracket (QTY: 1)

Includes 2 bolts

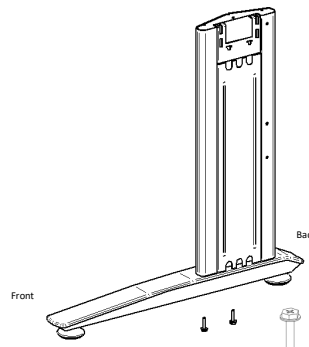
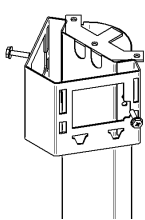

STEP 1: Attach 120degree bracket to the 120degree back corner leg as per above, using Bolts supplied with the bracket.

STEP 2: Attach Leg column to Foot, using bolt A. Make sure the bolt holes on the leg column are to the back of the foot as per above.



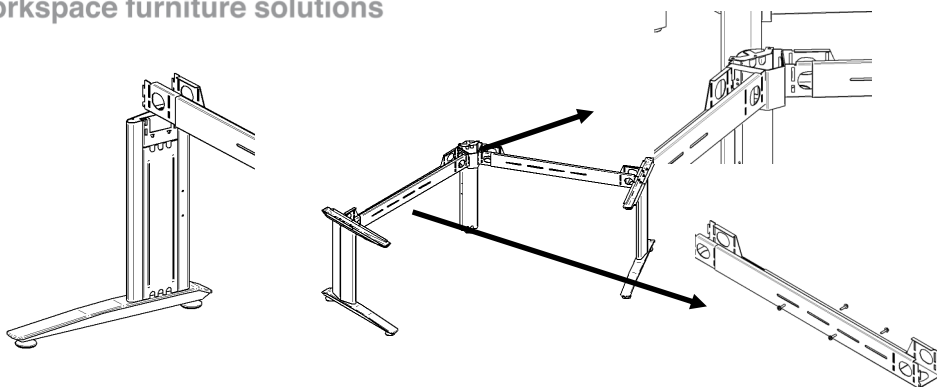

STEP 3: Attach the Extendable beam to the leg column as per above, the open side of the beam to the back. Use a nylon hammer to hit the top of the beam into place. Using the bolts supplied with the beam, Install 2 bolts front and back of each beam as per above.

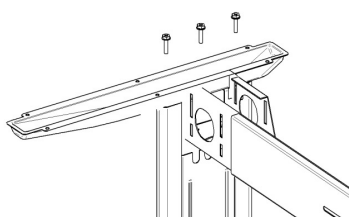

STEP 4: Attach the top plates to the leg columns using bolt A.

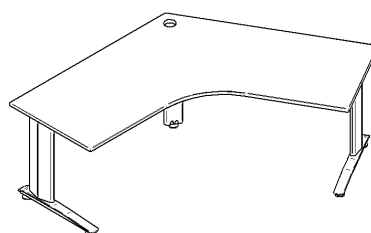

STEP 5: Place Desk top on the base frame, Attach the desk top to the frame with bolt B.

