

# CLASSIC TABLE **ASSEMBLY GUIDE**





## Tools Required



Battery Drill



Square Drive Tip

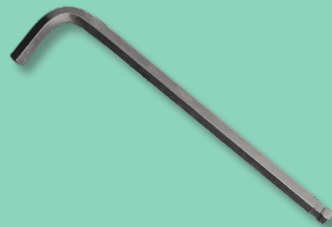

Hex Key 5mm



\*\*Wall fixing to attach Wall mounted table to the wall\*\*

# Accent

workspace furniture solutions



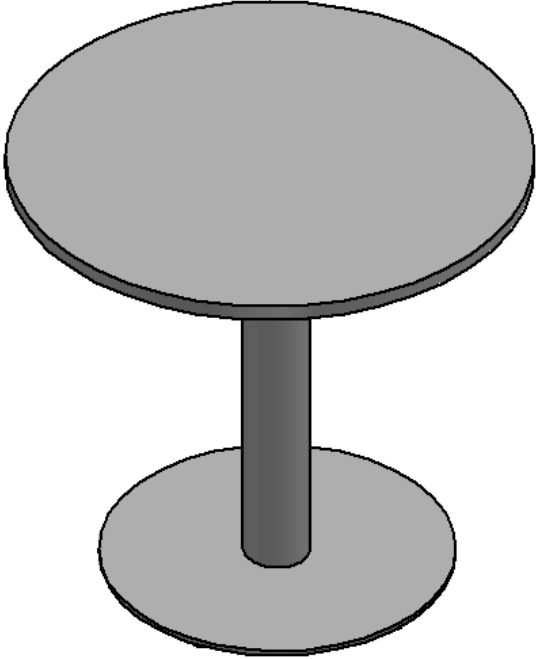
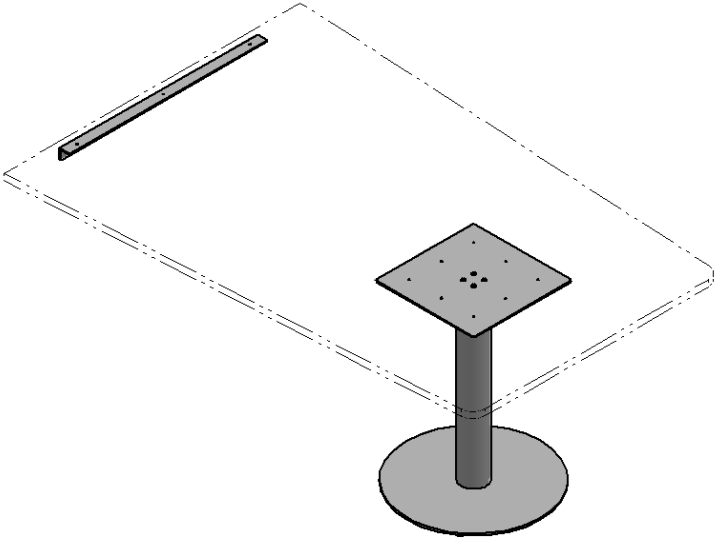

# TABLE OF CONTENTS

TABLE	PAGE	IMAGE
Classic Table		
Classic Trapezium Wallmounted		

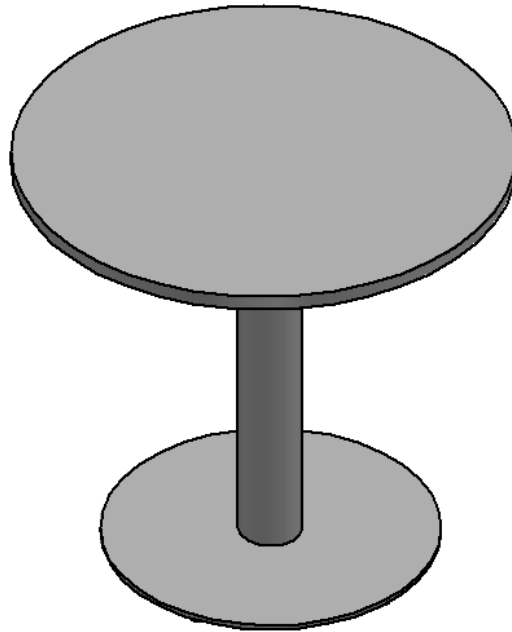
# CLASSIC TABLE

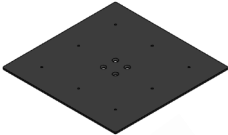
## PARTS LIST



NO.	NAME	QUANTITY	IMAGE
1	Table Top	1pc	
2	Top Plate	1pc	
3	Screws	8pcs	
4	Stem	1pc	
5	M8 CSK	8pcs	
6	Base Plate	1pc	

# CLASSIC TABLE

## ASSEMBLY INSTRUCTION

### STEP 1

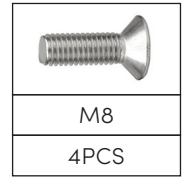
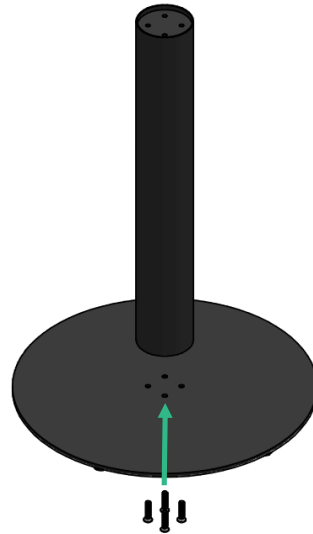

Attach base plate with stem.

### STEP 2

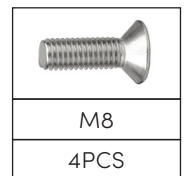
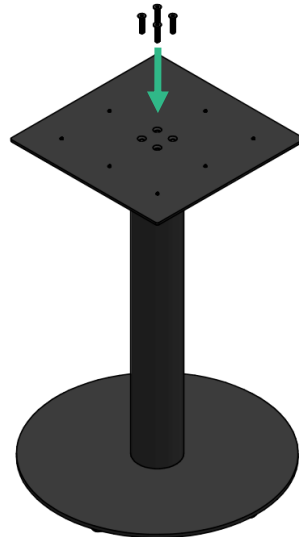

Attach top plate.

### STEP 3

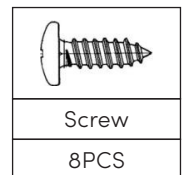
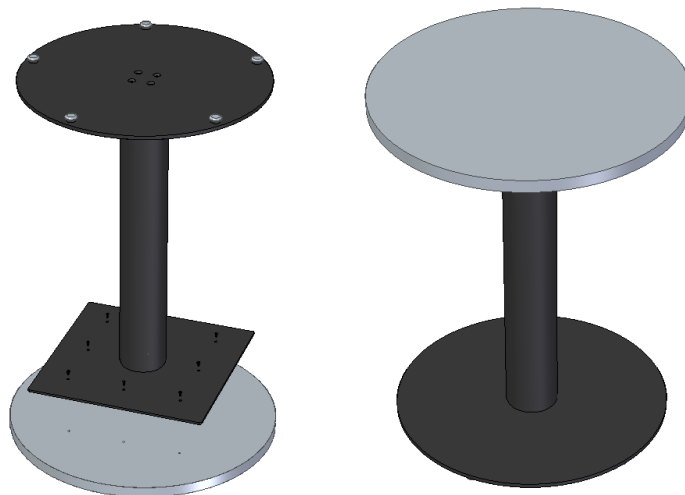

Attach table top.

# TRAPEZIUM WALLMOUNTED

## PARTS LIST

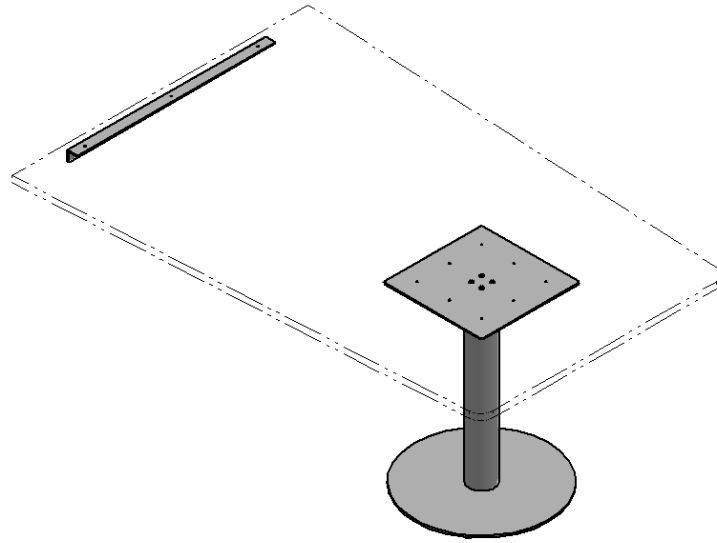

NO.	NAME	QUANTITY	IMAGE
1	Table Top	1pc	
2	Top Plate	1pc	
3	Screws	8pcs	
4	Stem	1pc	
5	M8 CSK	8pcs	
6	Base Plate	1pc	
7	Wall Mount Angle Bracket	1pc	

# TRAPEZIUM WALLMOUNTED ASSEMBLY INSTRUCTION

## STEP 1

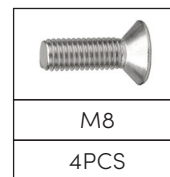
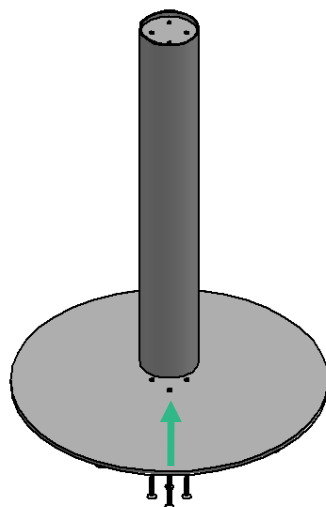

Attach stem to base plate.

## STEP 2

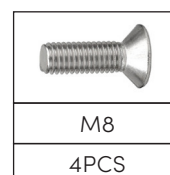
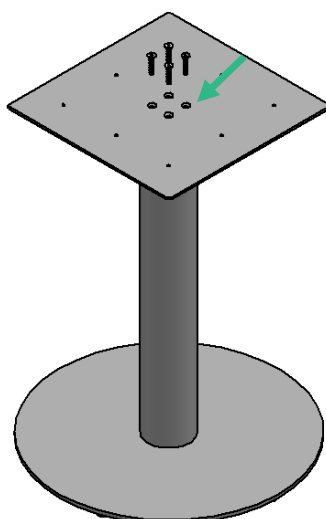

Attach top plate the stem.

## STEP 3

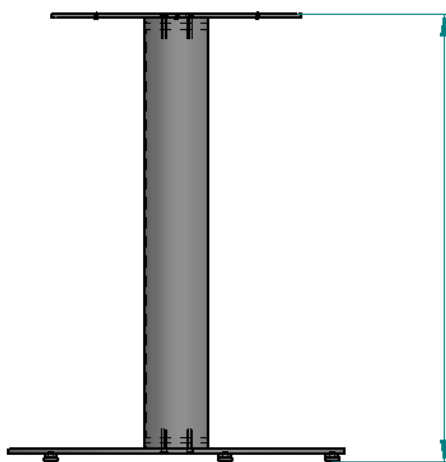

Measure the overall height of the table base.

# TRAPEZIUM WALLMOUNTED ASSEMBLY INSTRUCTION

## STEP 4

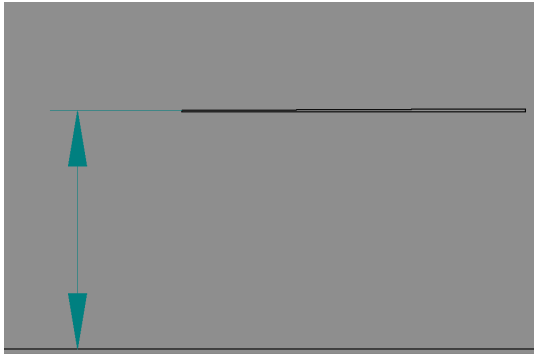

Measure and mark the table base height on the wall.

## STEP 5

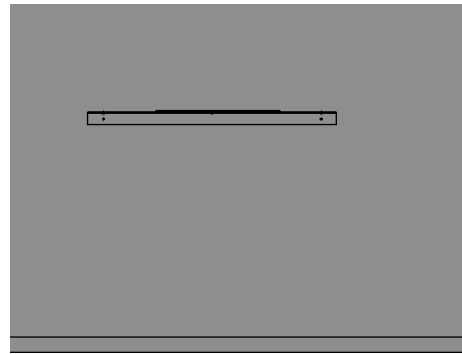

Locate at least 2 studs on the wall. Pre-drill the wall bracket and attach it to the wall.

*\*\*Use strong suitable wall fixing screws\*\**

## STEP 6

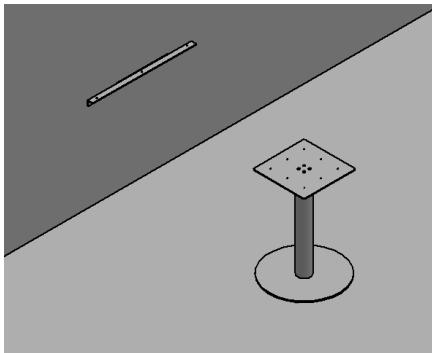

Place the table frame near the wall.

## STEP 7

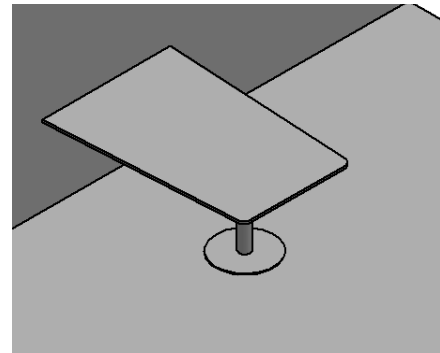

Place the table top onto the wall bracket and table base.

## STEP 8

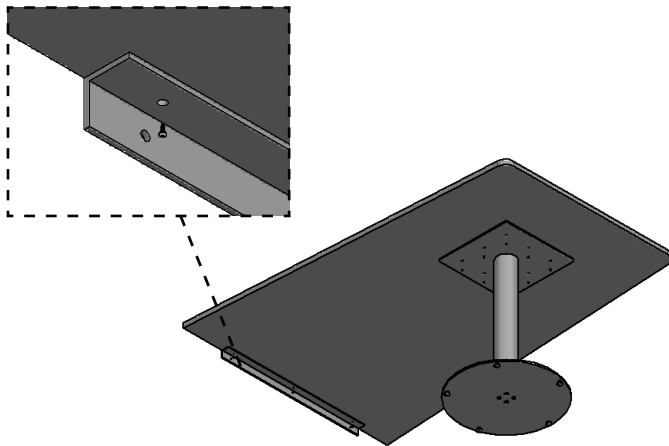

Attach the table top the wall bracket.

## STEP 9

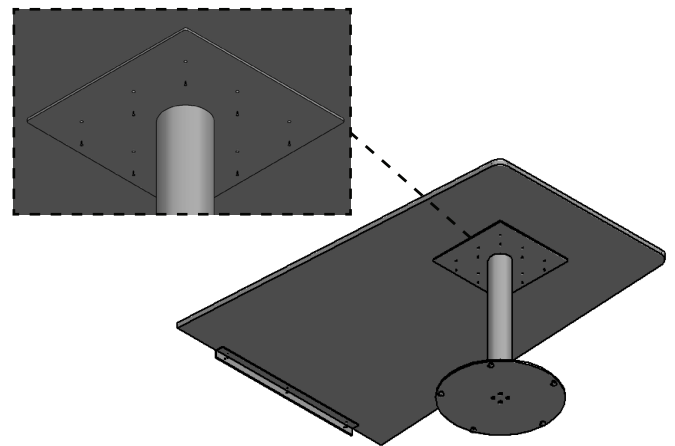

Attach the table to the base.



# FACTSHEET

## CARE & MAINTENANCE

### GENERAL CARE – INFORMATION

- Avoid scourers and abrasives as they will damage the surface.
- Don't place hot objects, electrical appliances or pots straight from the oven or cooker onto your laminate surface.
- Don't cut on the laminate surface.
- Keep waxes and polishes well away as they dull the natural shine.
- Do not use strongly acidic, alkaline cleaners or bleach for normal cleaning as these might etch the surface.

### GENERAL CARE – STREAKS

Streaky marks sometimes show on dark colours after cleaning. An all-purpose cleaner such as Mr. Muscle Surface & Glass or Ajax Spray n Wipe usually removes them.

### GENERAL CARE – GREASE

Using a mild dishwashing detergent in water will remove greasy marks. Dab, wait and wipe away. Finish with an all-purpose cleaner such as Mr. Muscle Surface & Glass or Ajax Spray n Wipe.

### GENERAL CARE – SPILLS

Laminate surfaces resist staining from most household chemicals. With some accidental spills however, prompt action is essential. Wipe off beetroot, grape and berry juices, first aid preparations, concentrated bleach, oven cleaners, dishwasher detergents, artificial dyes, hair colouring and solvent based pen ink immediately. Specialty glues such as Super Glue must also be removed straight away with acetone (nail polish remover).

### GENERAL CARE – STAINS

If the stain won't budge with Mr. Muscle Surface & Glass, try methylated spirits or dab the stain with a diluted bleach mixture (1 part bleach to 8 parts water); leave for 3 minutes then wash off with water and dry. Finish off with Mr. Muscle Surface & Glass. Only as a last resort if a stain persists try 2 or 3 rubs with a crème cleanser or white toothpaste, wash and dry. Please note that bleach or these abrasive cleaners may irreversibly damage the laminate surface.

### GENERAL CARE – SCRATCHES

Laminate surfaces will withstand normal wear and tear, but can be damaged by scratching or cutting with utensils, knives and unglazed pottery. Darker colours will show scratches more readily than lighter colours. In general, dark colours and high gloss surfaces require more care and maintenance than lighter colours or lower gloss colours. To minimise scratching, always place and lift objects from the surface – never drag or slide them across the surface.

# Accent

## WARRANTY

## REGISTRATION

At Accent Group, we are committed to delivering not only exceptional products but also exceptional customer experiences. We take immense pride in crafting each item with the utmost care to meet your expectations and your purchase is backed by our 15-year Warranty (terms and conditions apply). To make the most of this extended warranty and to facilitate any future claims seamlessly, we kindly request you to complete our Warranty Registration Form by scanning the QR code below. Providing us with your details will enable us to serve you better and ensure your peace of mind throughout the warranty period.

View full Warranty details on our website – [www.accentgroup.co.nz](http://www.accentgroup.co.nz)

### CUSTOMER PRODUCT REVIEW TEAM

As a company committed to excellence, we continuously seek ways to enhance our offerings and deliver the finest in the NZ market. We invite you to take part in a Customer Product Review. Your valuable feedback matters to us, and joining the team is effortless. Approximately three months after your product delivery, one of our team members will reach out to you for a brief call. During this conversation, we will enquire about your product experience. Your insights on what's working well and what's not, whether the products have met your expectations, and if you would consider purchasing from Accent again are highly appreciated.

By joining our Customer Product Review Team, you play an integral role in shaping the future of our products, ensuring they align perfectly with your needs and preferences. Your voice will guide us in crafting even better offerings that resonate with customers like you.

We are truly excited about this opportunity to collaborate with you closely.

If you wish to participate in the program, please tick YES when you complete your Warranty Registration. Every quarter we'll select 4-5 customers to take part in the 3 month product review each customer we receive feedback from will receive a \$50 Prezzy card.

Don't hesitate to reach out to us if you have any queries or need assistance, give our team a call on 0800 826 126. Thank you again for choosing Accent Group products.

Best regards,  
The Accent Group Team

# Accent

SCAN TO REGISTER





# CLASSIC TABLE





**0800 126 826**

**support@accentworkspaces.co.nz**

**22 Hood Street Wellsford, Auckland 0900 New Zealand**