

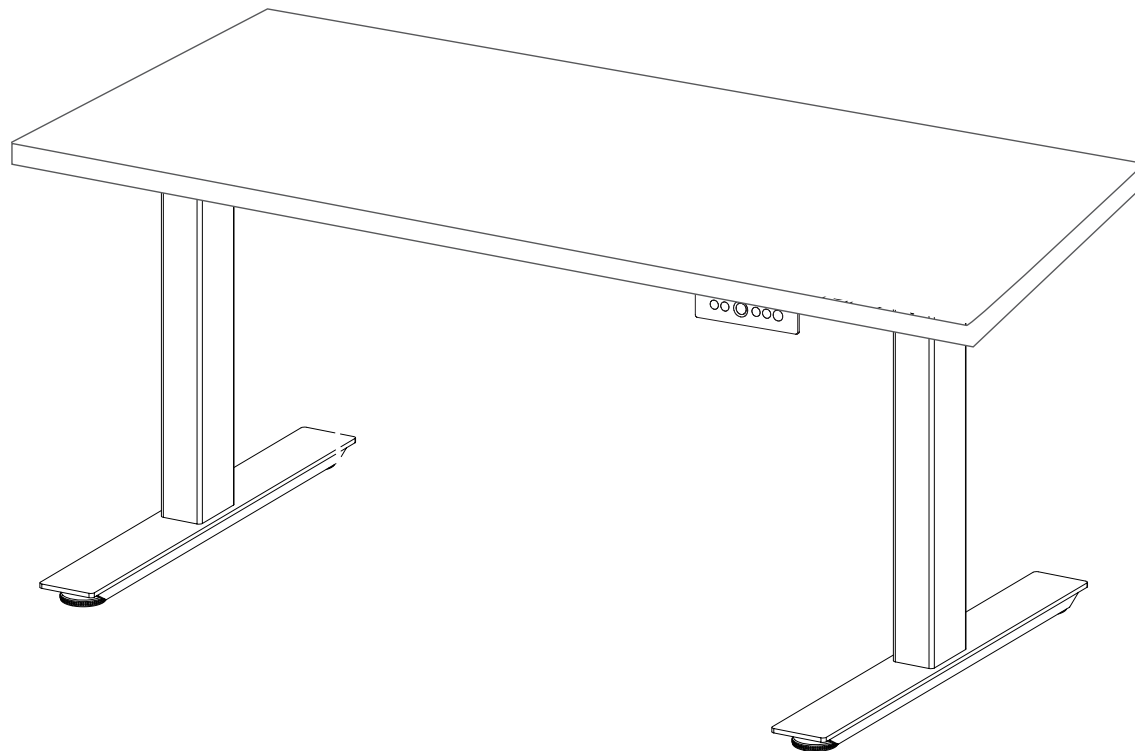

freeway

Agile

Installation Guide - Electric 3 Column - Twin Motor



Parts:

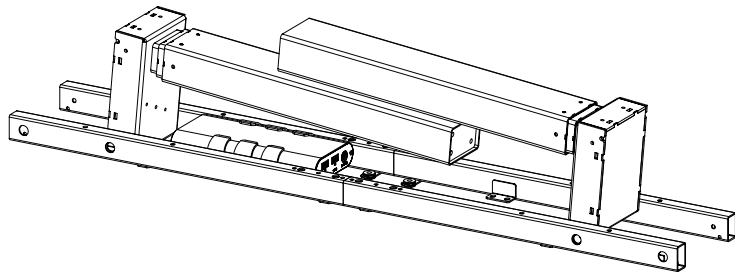

1 x Pre Assembled Frame

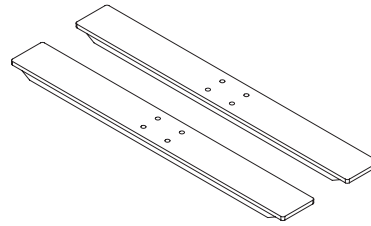

2 x Foot

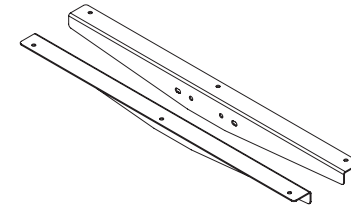

1 x L&R Support Bar Pair

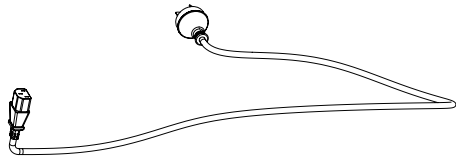

1 x Power Cord

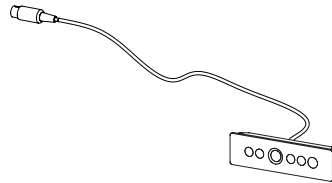

1 x Handset

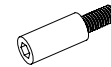

4X M6X12



8X M8X20



12X S75.0X23

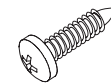

2X ST4X16

Step 1

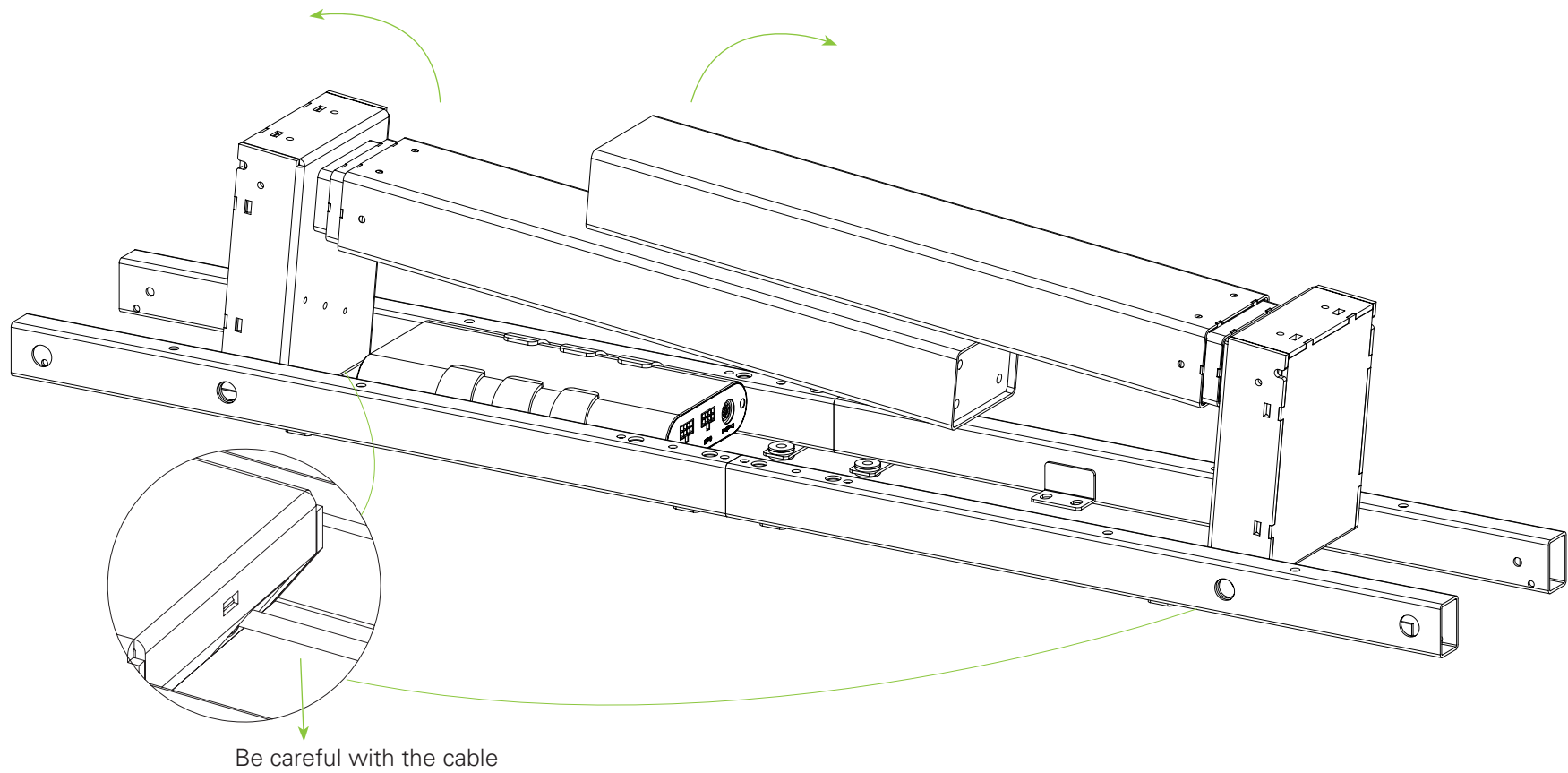

Step 2

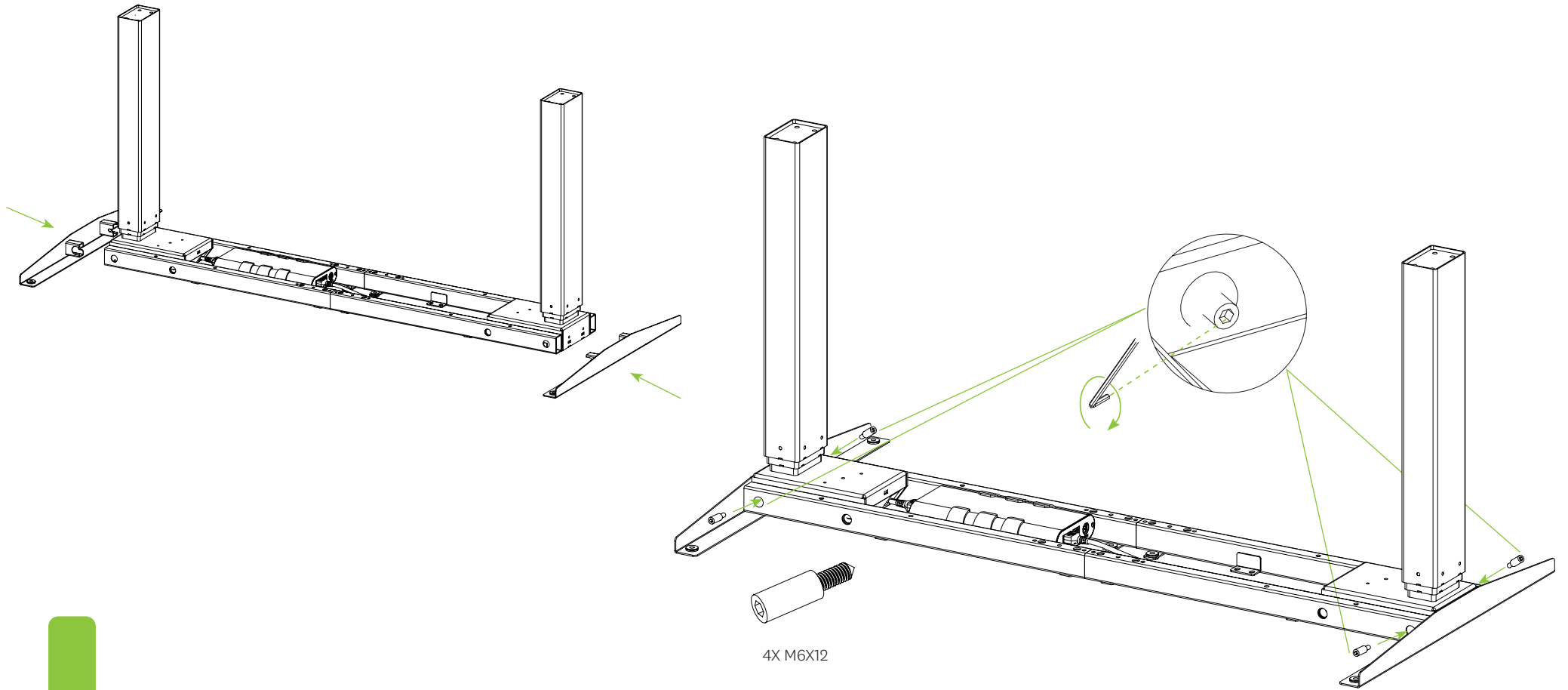

Step 3

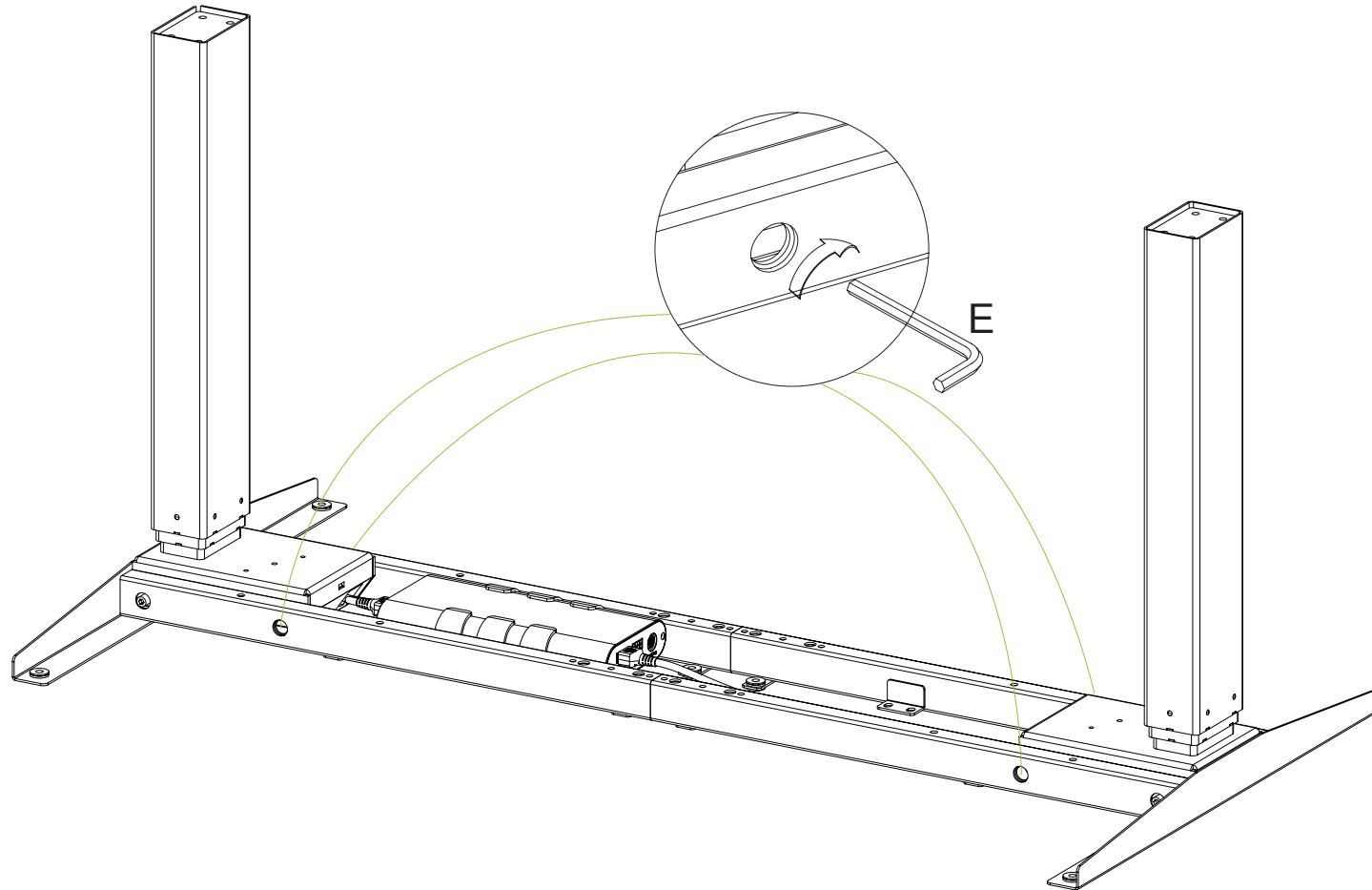

Step 4

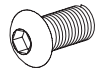

8X M8X20

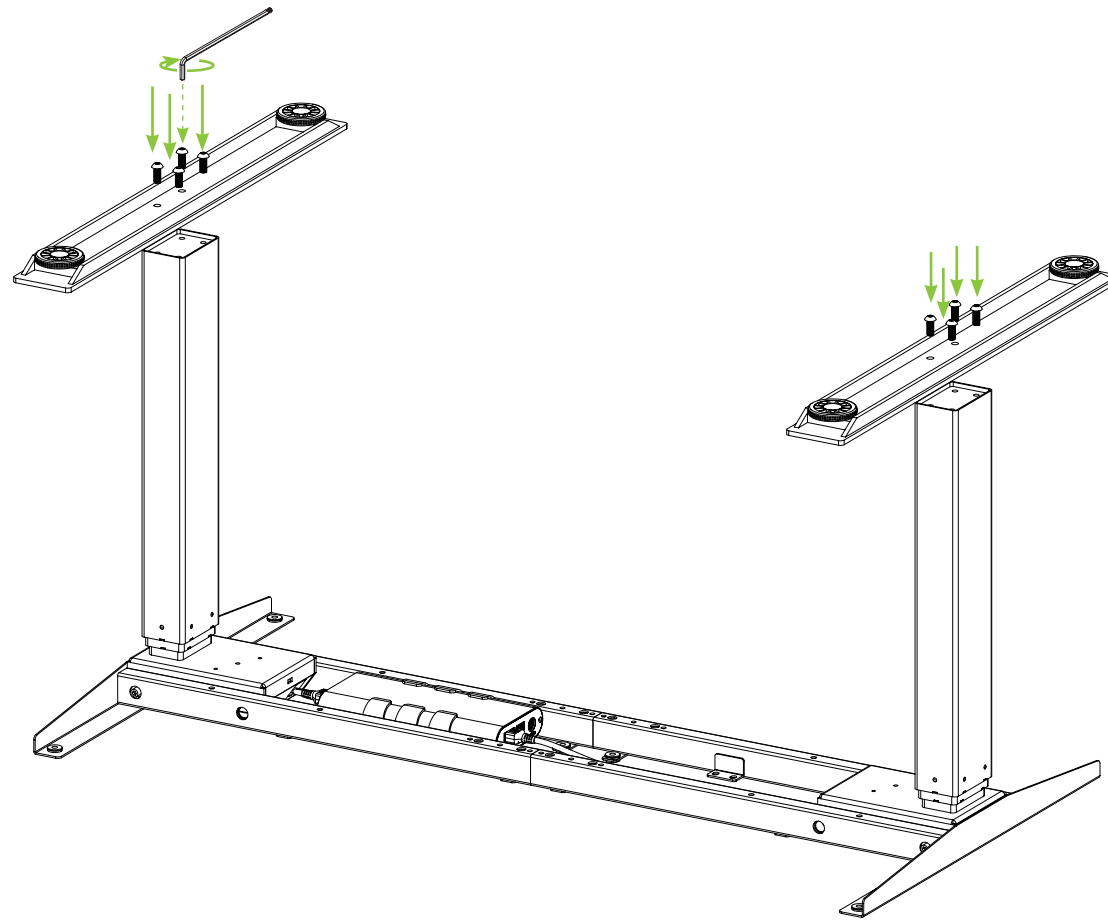

Step 5

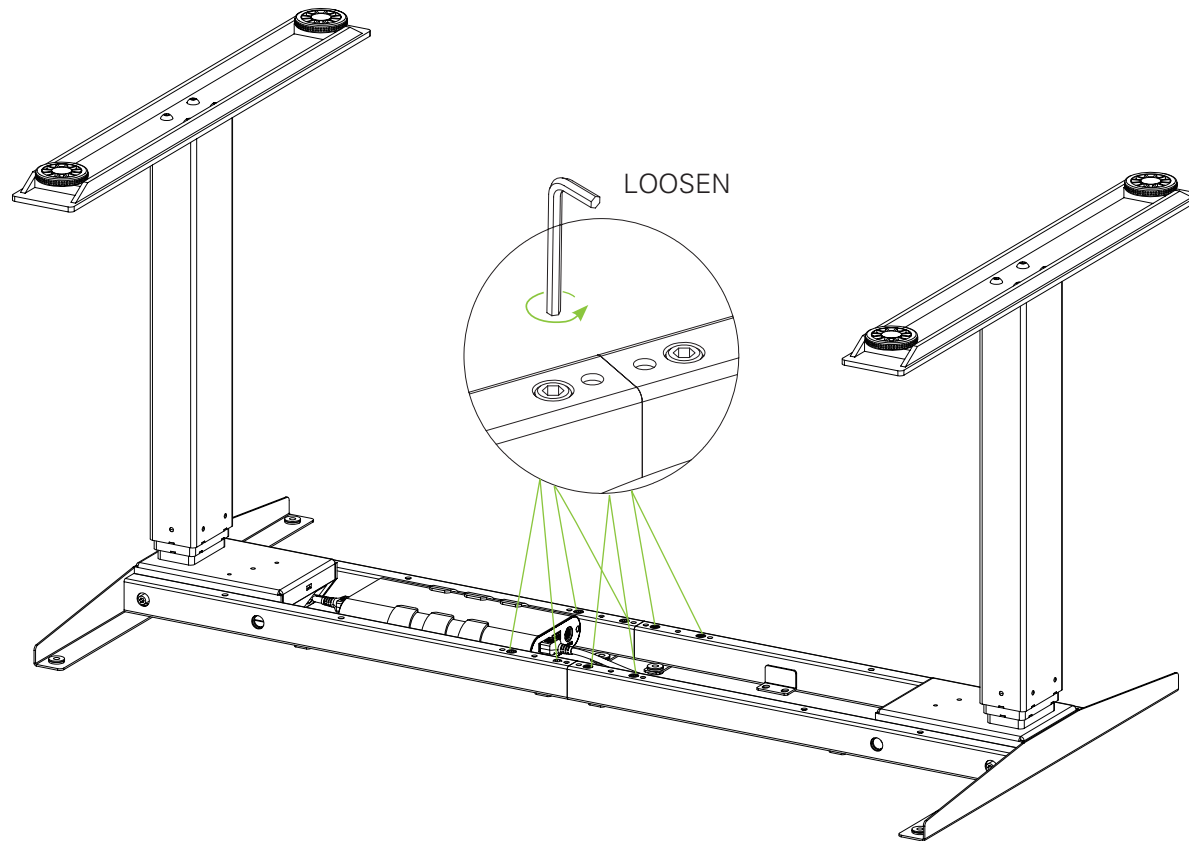

Step 5

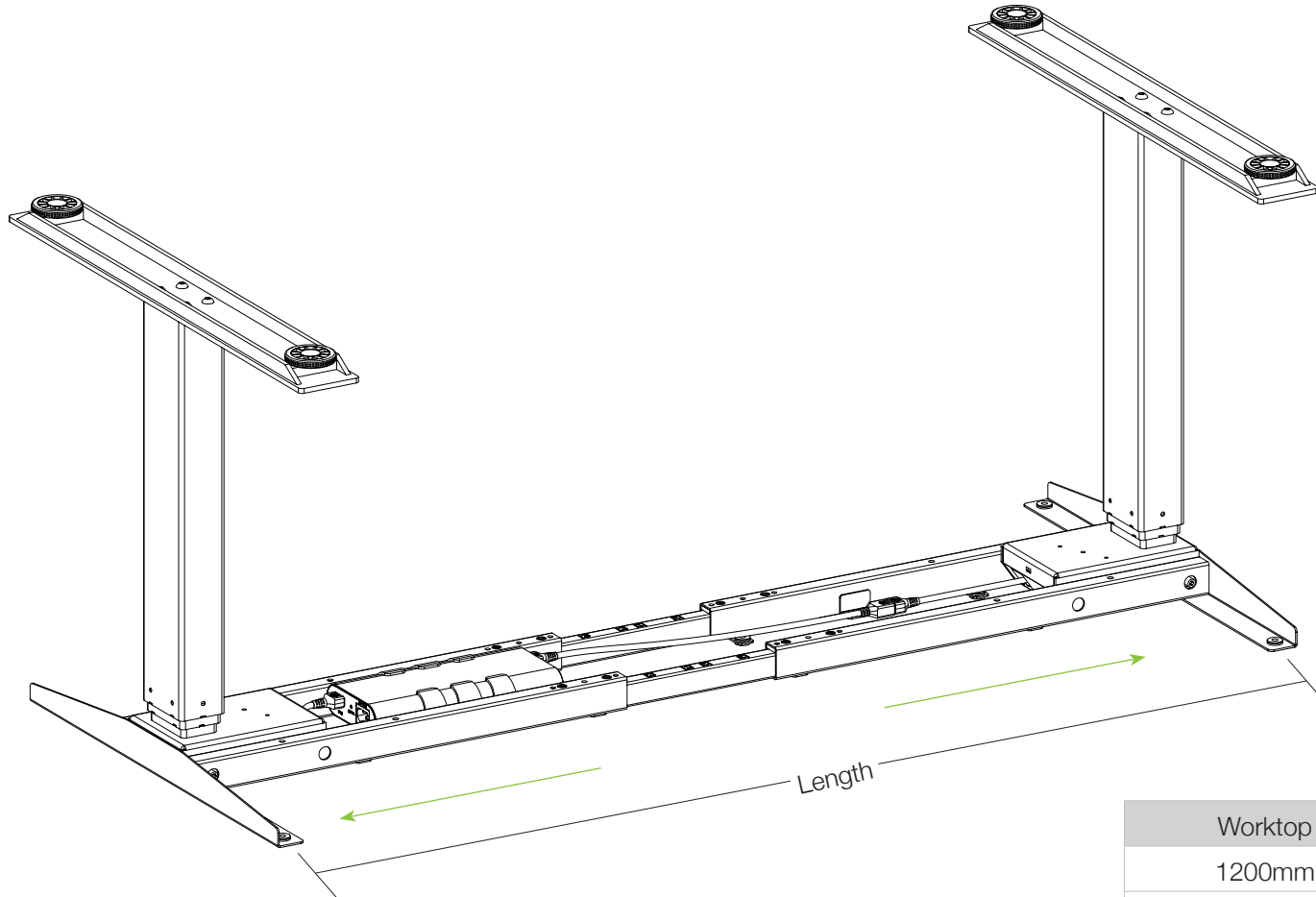

Worktop	Length
1200mm	1125mm
1500mm	1425mm
1800mm	1725mm
2100mm	2025mm

Step 7



12X S75.0X23

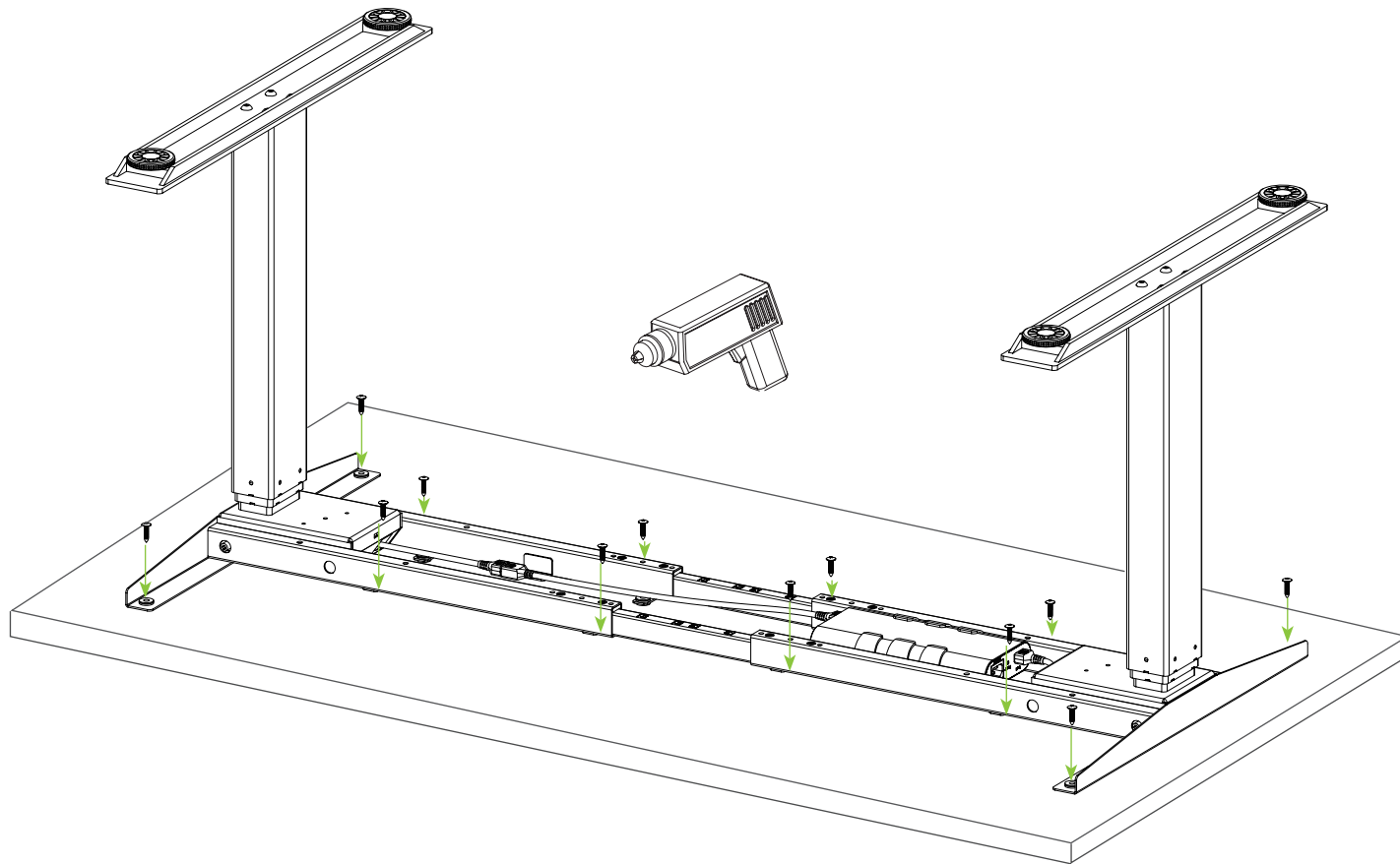

Step 8

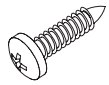

2 X ST4.2X16mm

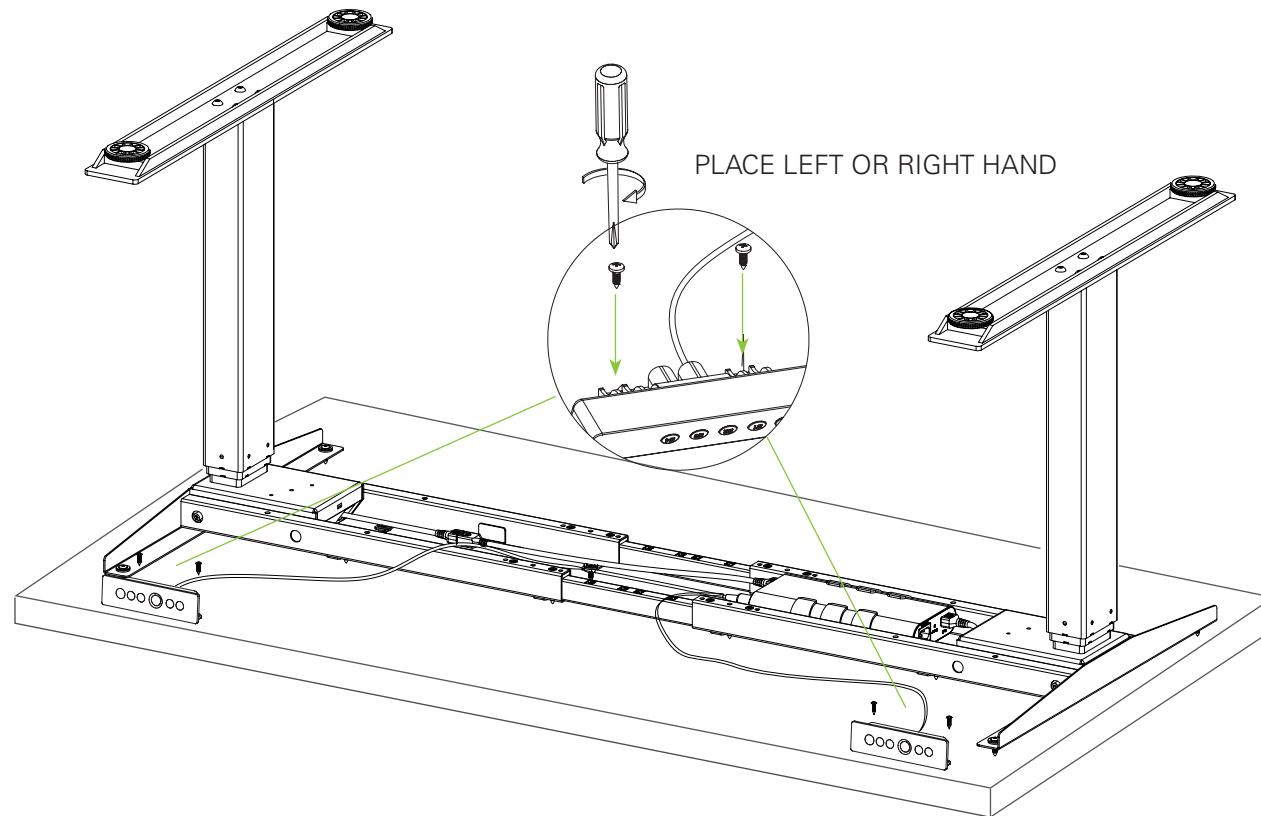

Step 9

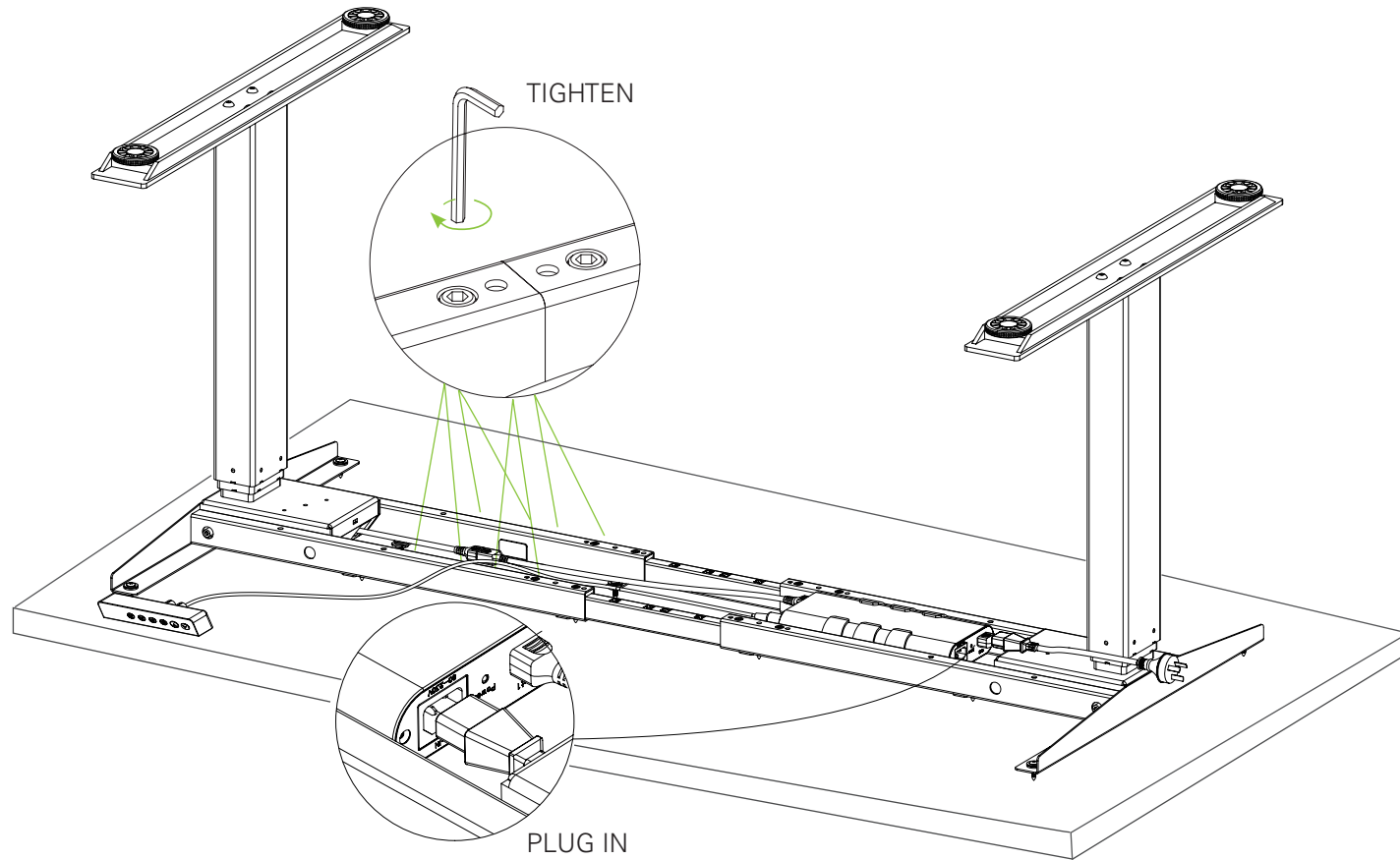

Complete

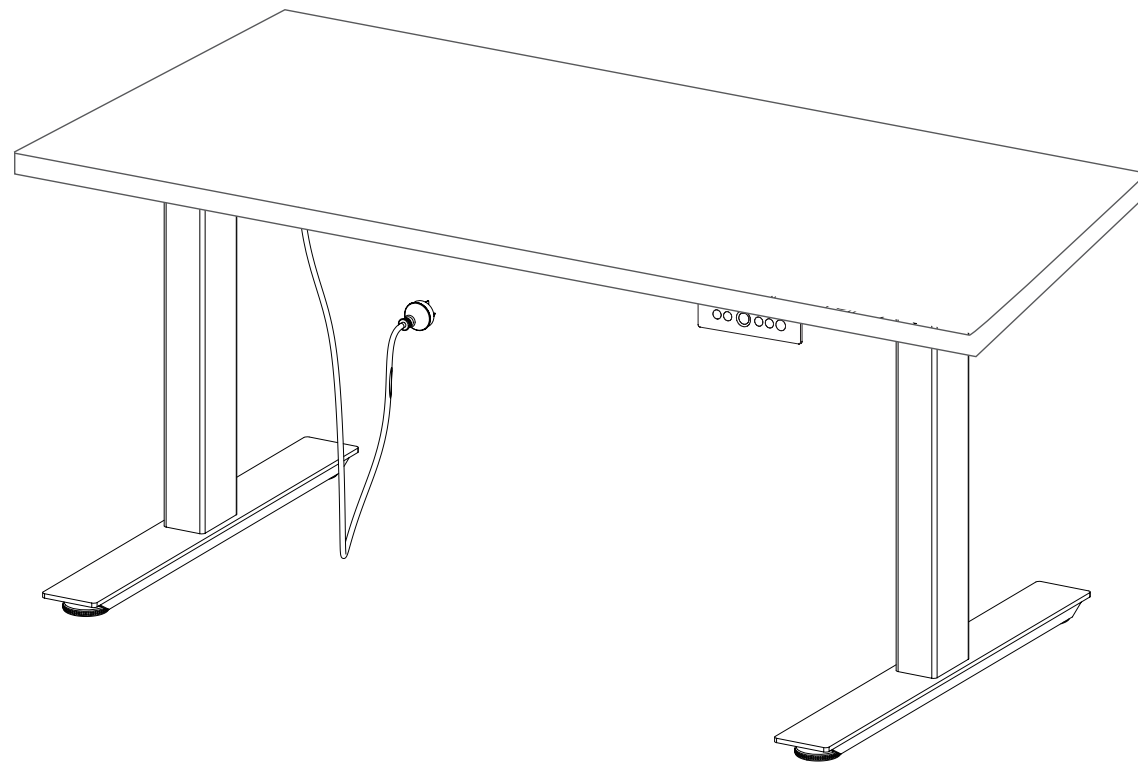

Optional Desk Hung Screen

Installation Guide

Step 1

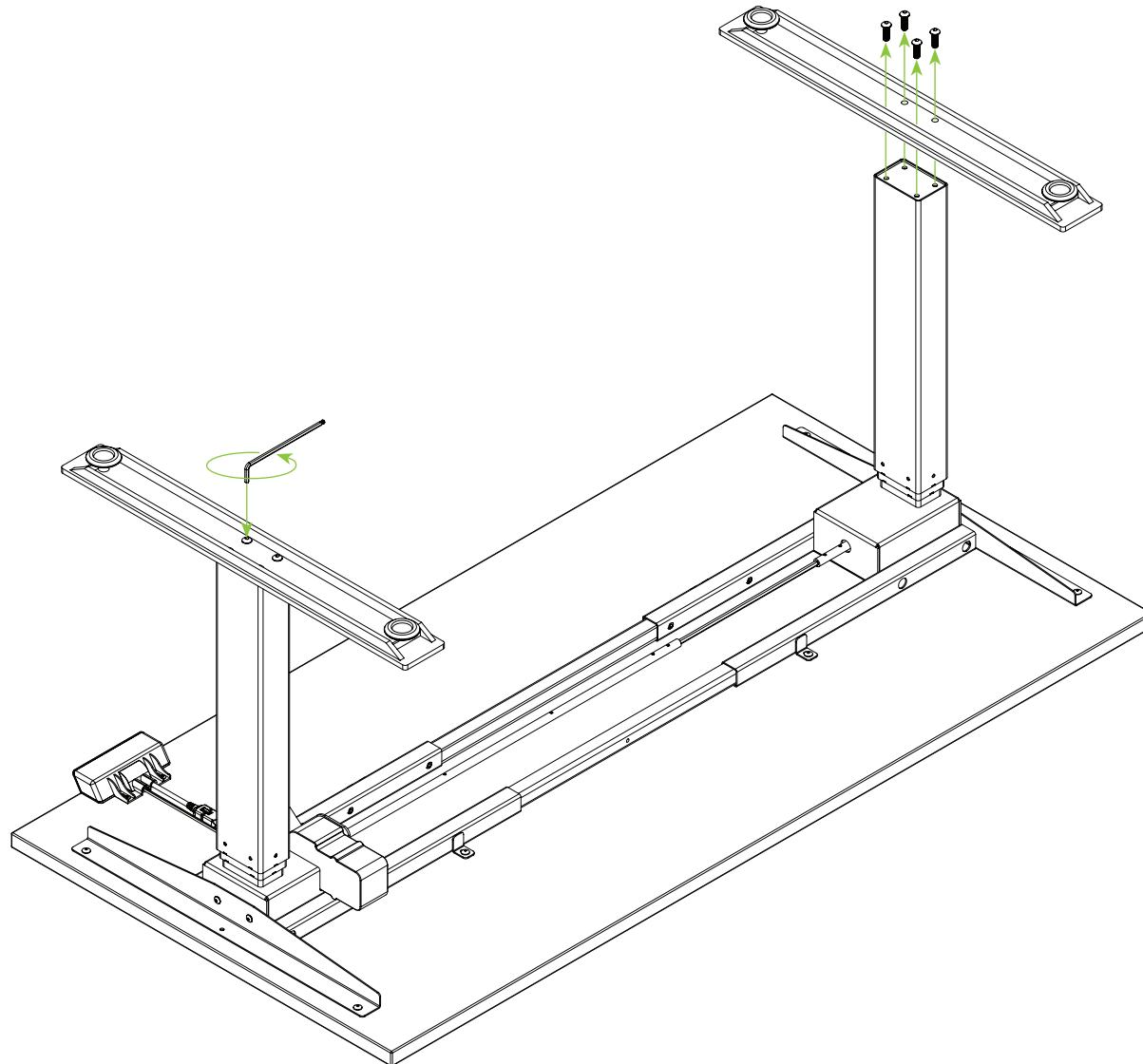

Optional Desk Hung Screen

Installation Guide

Step 2

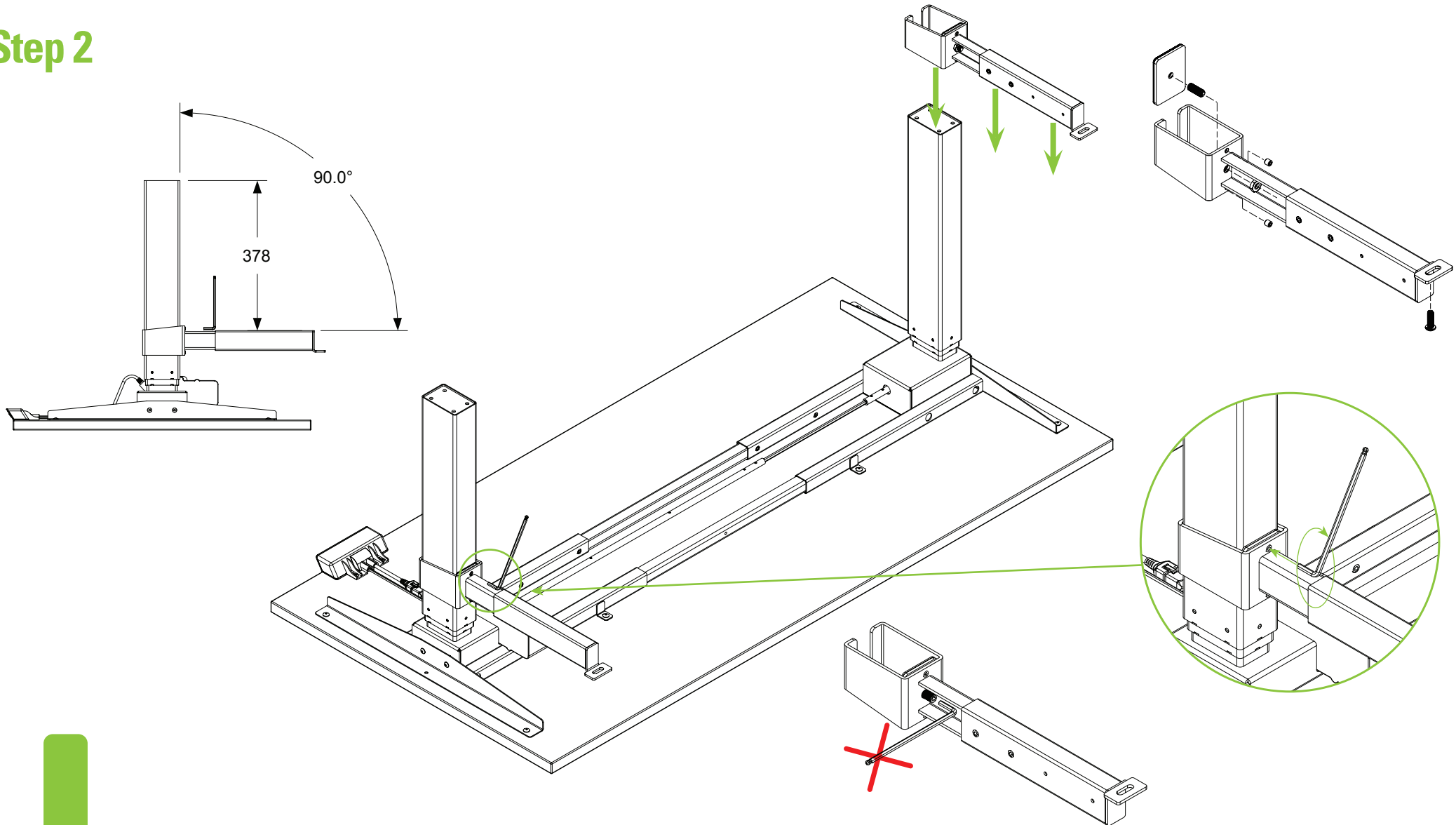

IMPORTANT

DO NOT TIGHTEN MIDDLE SET SCREW
Failure to comply will void warranty

Optional Desk Hung Screen

Installation Guide

Step 3

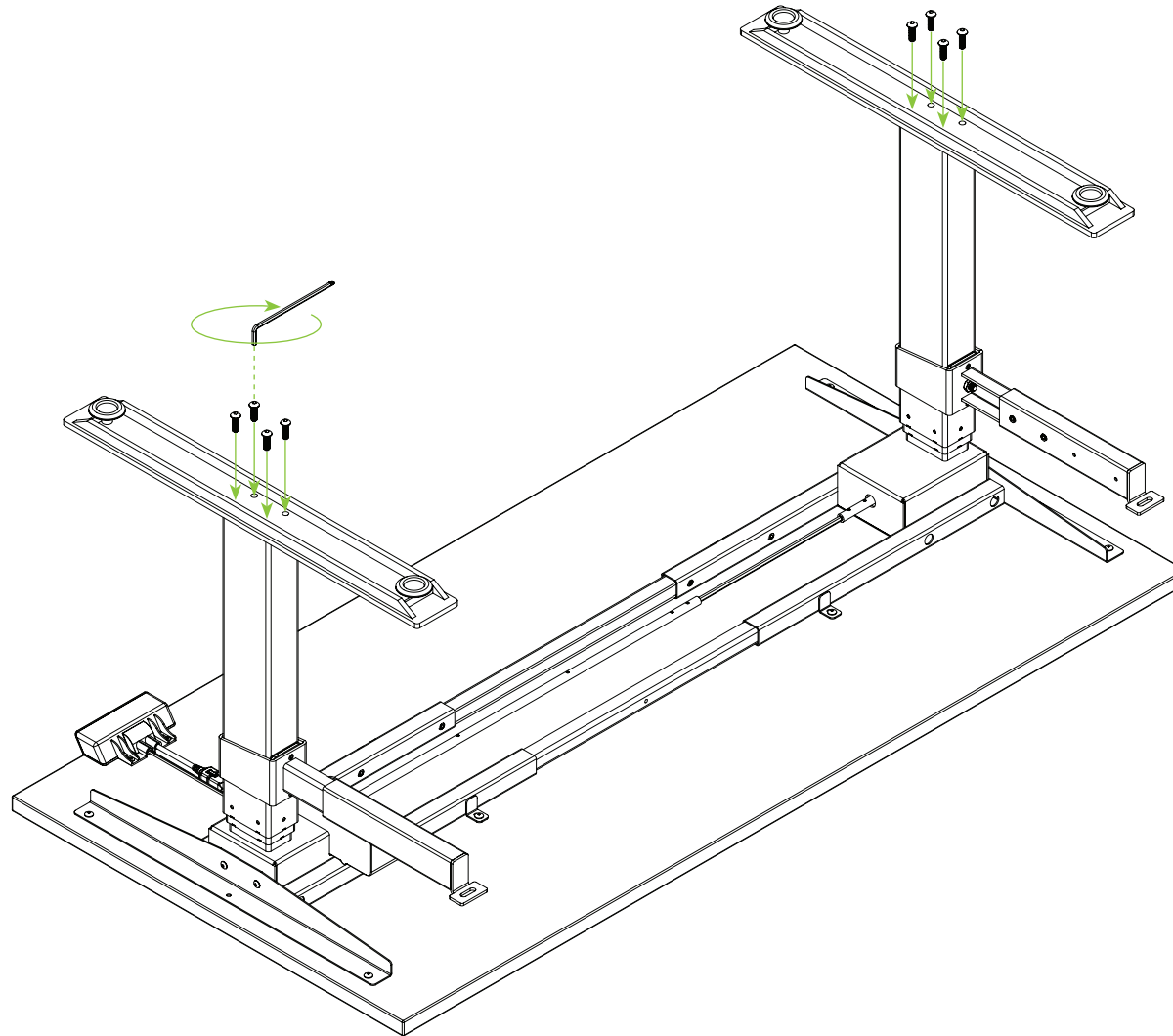

Optional Desk Hung Screen

Installation Guide

Step 4

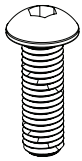

2 x M8x25

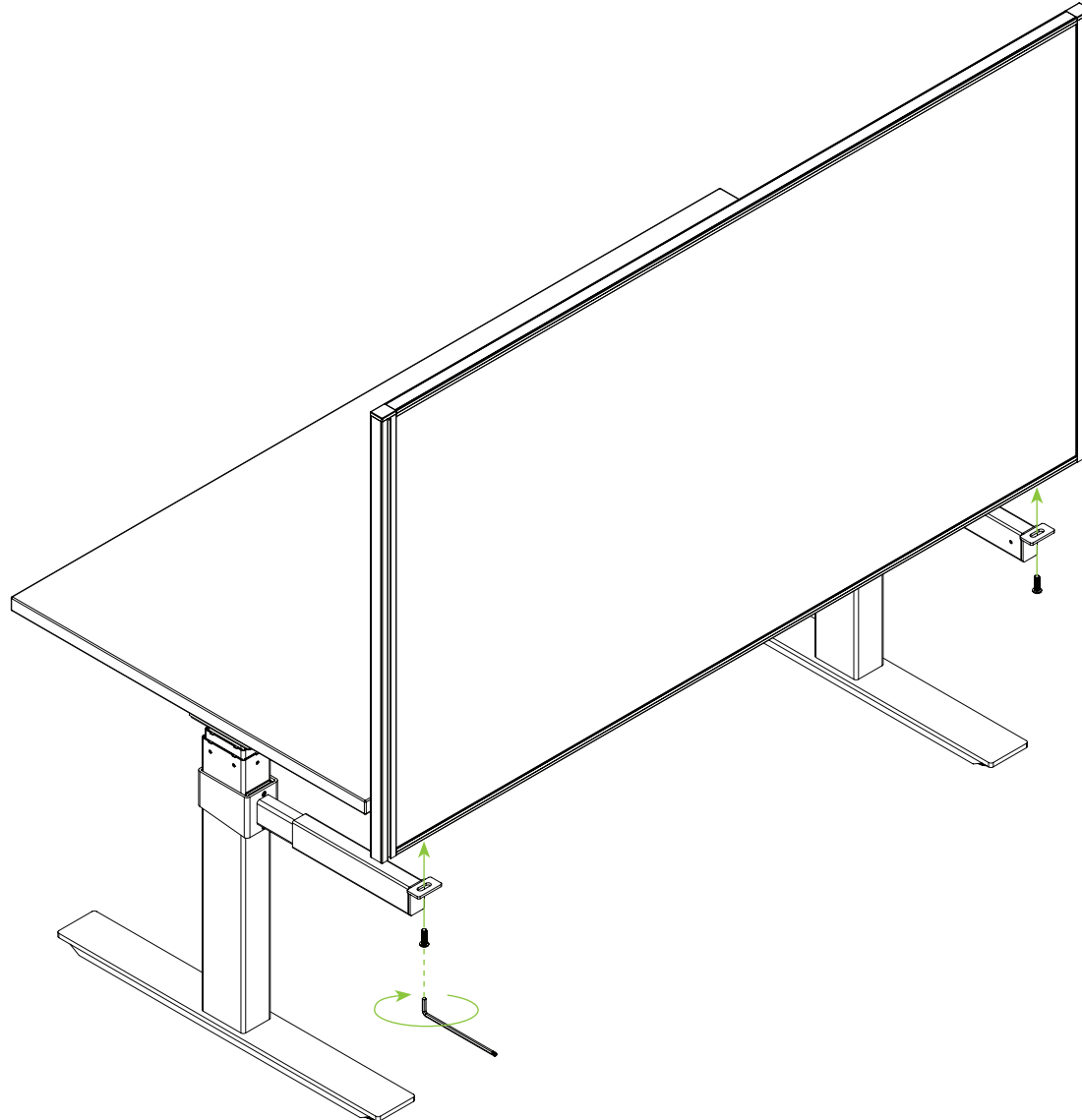

Optional Desk Hung Screen

Installation Guide

Step 5

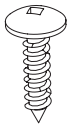

4 x ST5.0x23

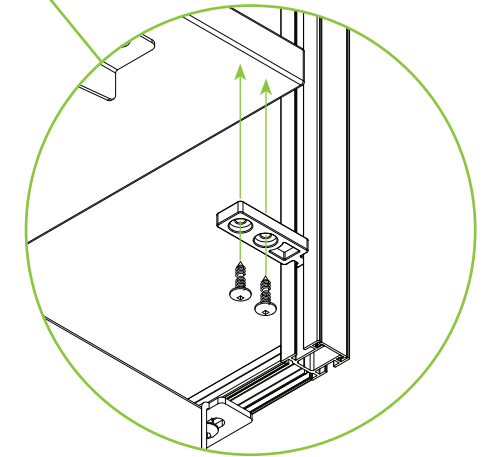
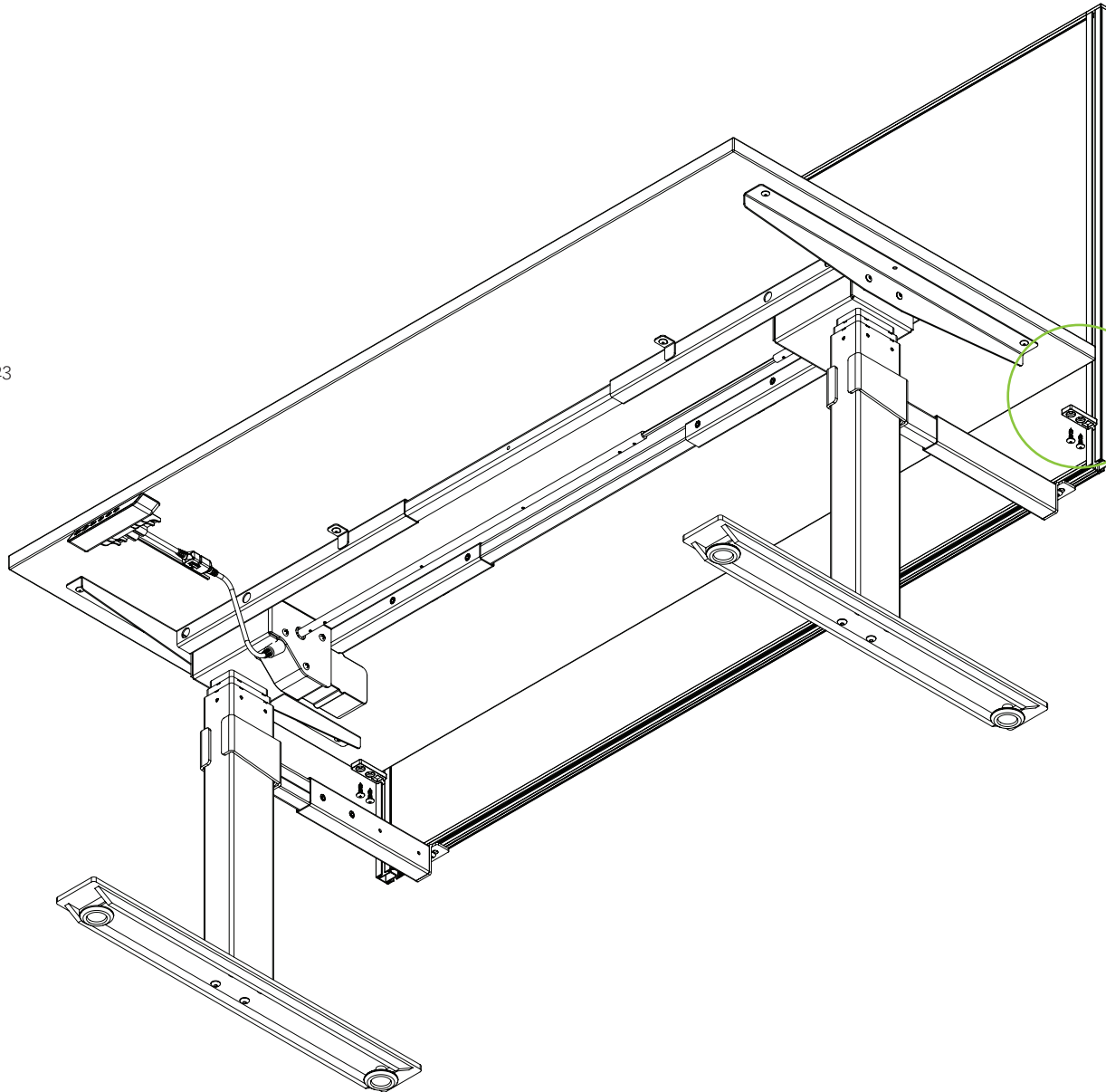

Optional Desk Hung Screen

Installation Guide

Step 6

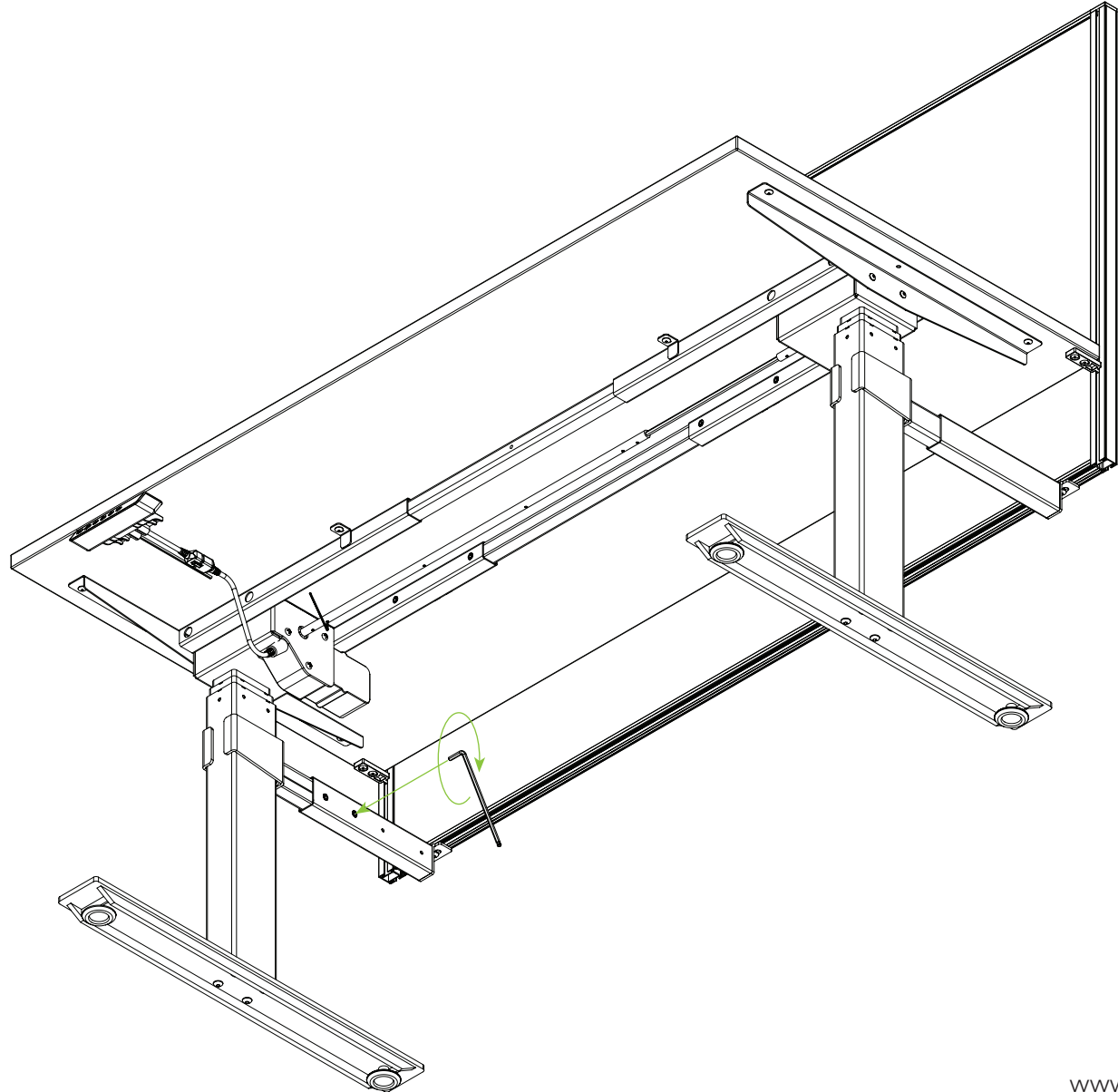
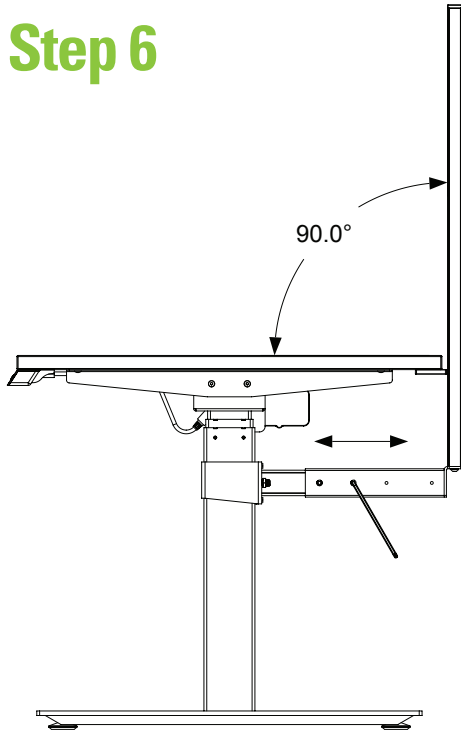

Optional Cable Tray

Installation Guide

Step 1



4 x M6x10

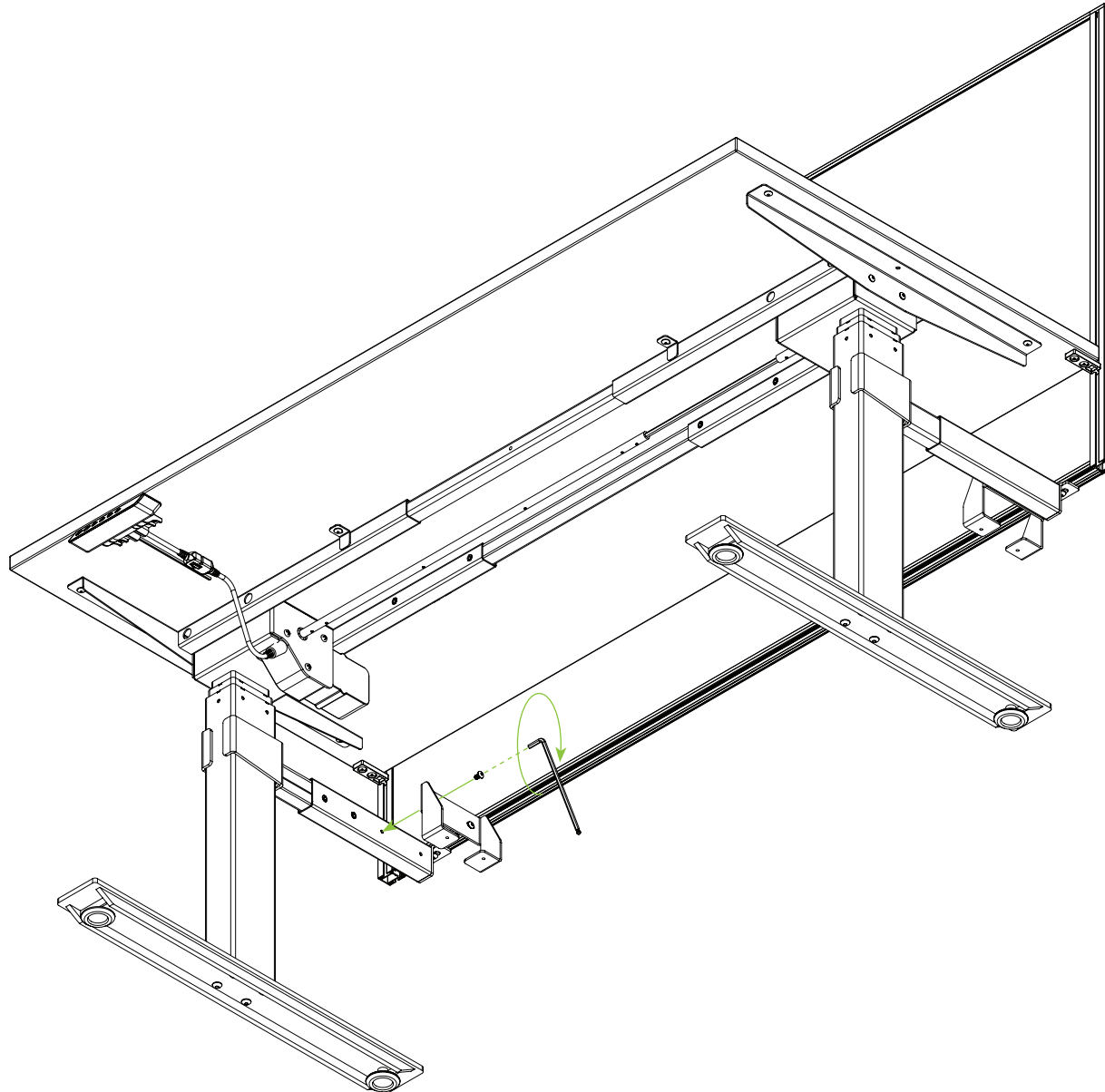

Optional Cable Tray

Installation Guide

Step 2



4 x M5x6

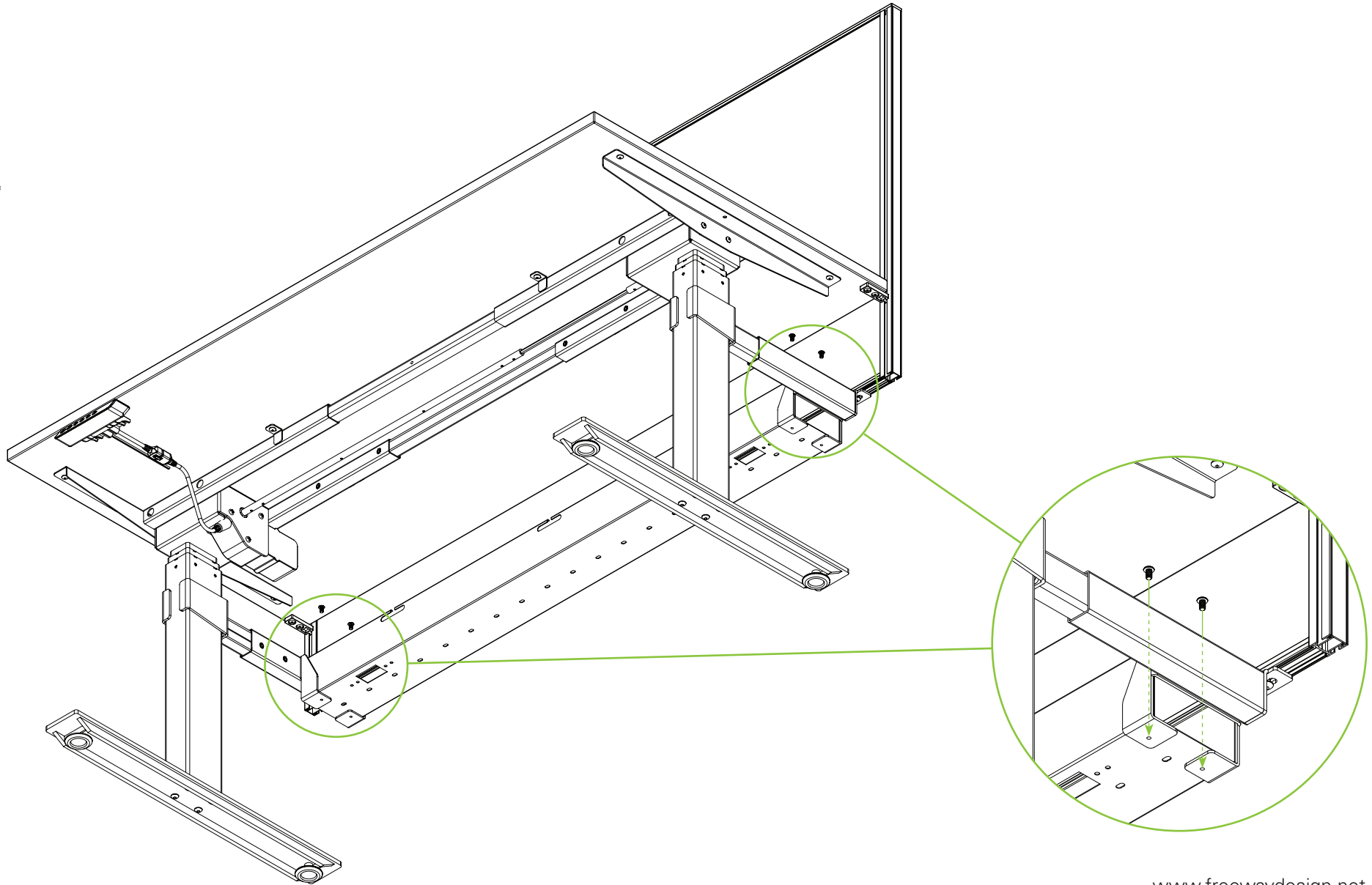

Step 1 & 2

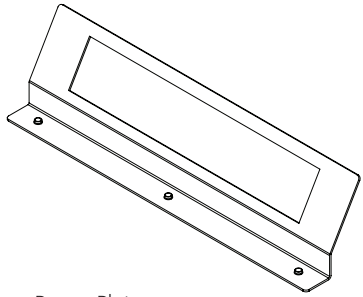

1 x Power Plate

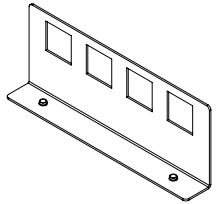

1 x Data Plate



5 x Screw

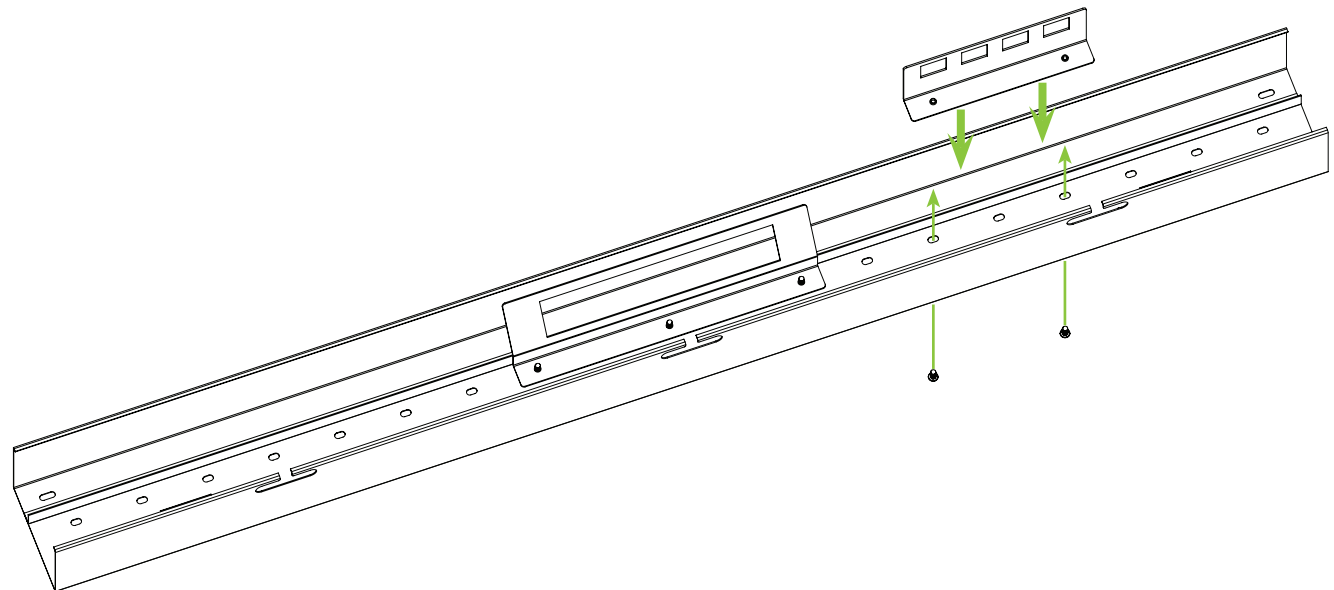
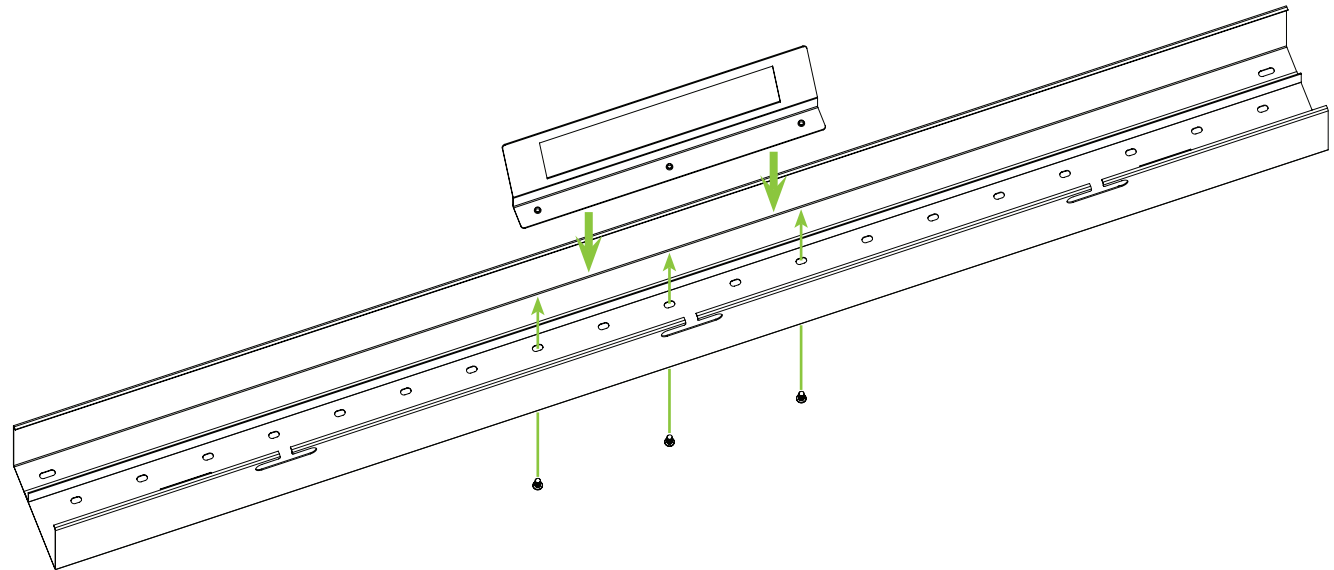

Step 3 & 4

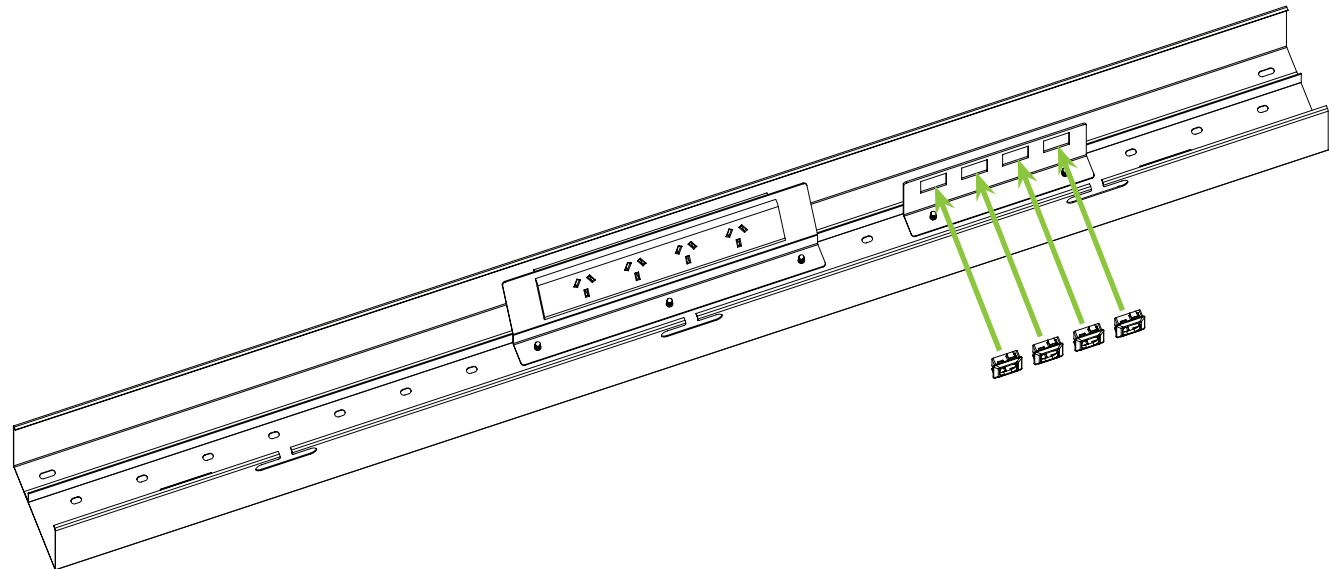
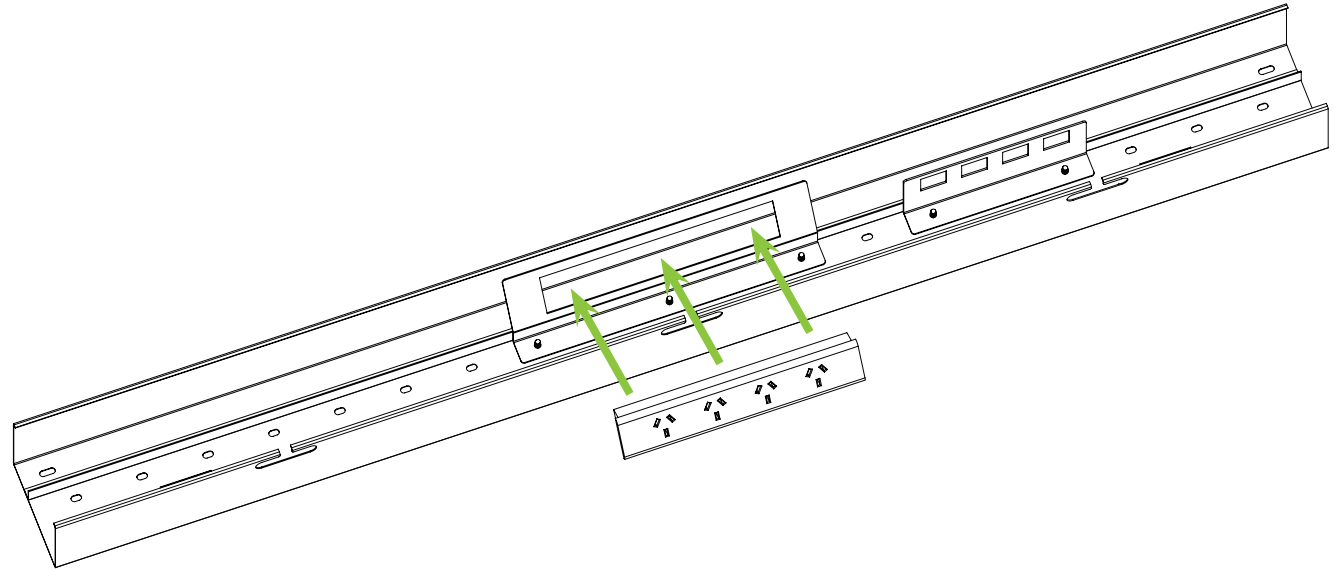

Directions For Use

IMPORTANT

Please carefully read the assembly manual and direction for use prior to instalment, use and maintenance of the table frame to gain a complete understanding of its contents. It provides you with important information about the safety, use, installation and maintenance of the table.

WARNING: FAILURE TO COMPLY WITH OR OBSERVE ALL ASSEMBLY, SAFETY AND OPERATION INSTRUCTIONS REGARDING THE USE OF THIS PRODUCT MAY RESULT IN SERIOUS BODILY INJURY.

SAFETY

- The table must be used in a safe manner. Inappropriate use may cause damage to the table and/or cause bodily harm to the user or persons nearby.
- Do not tamper with electrical components as this may lead to serious bodily harm.
- Only connect the electric table frames to the prescribed mains power voltage
- Do not use the table frame to lift people.
- Please retain this operation manual and pass it on to any future owner.

USAGE

- The height-adjustable table is designed for use in dry work environments only.
- The table height is infinitely adjustable within its height range so that it can be set to the user's most ergonomic working height. The user should seek professional help to establish their optimum working height.
- The table has been designed as a devise to elevate the users work surface and associated office peripherals. Do not use the table frame for any other purposes than that which it has been designed for. Any other use is at user's own risk!
- Do not crawl, lie or move around under the table frame, and do not sit or stand on the table frame.
- CHILDREN should only use the table when supervised by adults.
- Liability: The manufacturer accepts under no circumstances warranty claims or liability claims for damages arising from improper use or handling of the table frame other than that described in this operation manual.

SET UP AND INSTALLATION

Assemble the table frame according to the assembly instructions on pages 4 - 12.

- Place the table in a safe distance from window frames, radiators, furniture etc. so that persons cannot become trapped.
- Level the table with the adjustable feet ensuring that the table is stable.
- Check that no cables can get jammed.
- Connect the table to the 110 or 230 VAC power outlet.

The table is now ready for use.

Directions For Use

MAINTENANCE AND DEFECTS

- The table does not require any maintenance by usage as described in chapter 2 in the directions for use.
- The table is only to be maintained with a wrung cloth.
- In the event of the occurrence of jarring sounds during operation, STOP using the table and please contact the dealer.

TECHNICAL DATA

Height Range: 610mm – 1230mm including worktop

Speed: ~30mm/s

Input Voltage: 100-240V AC 50-60Hz

Output Voltage: 24V DC 2.0A

Duty Cycle: 10% 2min on 18min off

MODE OF OPERATION

1. Use the arrow keys to manually change your height. Release the button to stop the desk.
2. Use M1 and M2 to set your desk to your chosen heights. Use the arrows to select your chosen height. Then hold the M1 for 5 seconds until you hear a 'beep'. That height is now saved. Do the same for M2.
3. After the control has been idel for 20 seconds, it will switch off. To wake it back up, press either of the arrow keys.

