

Electrical Test:

1. 100%Test(Open, short, miss wire)
2. Contact Resistance: 5 ohm max.
3. Insulation Resistance: 10M ohm min.
4. Hi-pot:100V DC/10ms

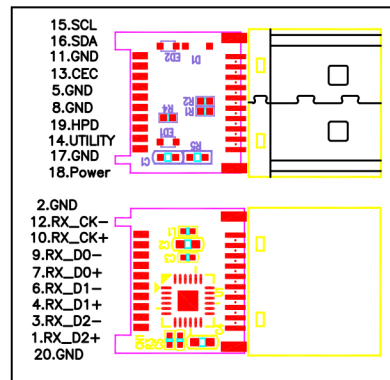

PIN Assignment

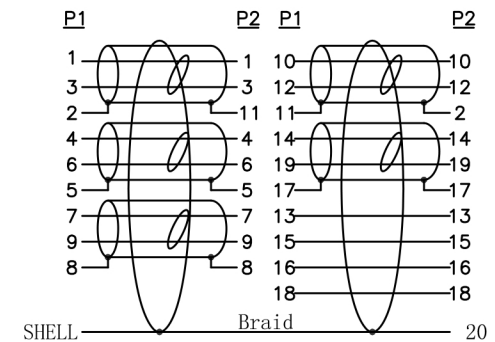

7	HDMI AM ABS Shell Color: Black	1	pcs		TOLERANCE		AYAGROUP.COM	TITLE: REDMERE HDMI CABLE(10.2G)	CUSTOMER :	CUSTOMER P/N :	SCALE	NONE	UNIT	MM	REV. A01	
6	HDMI 19P Male, Pin Gold Plated, Shell Gold Plated, Insulation: Black	1	pcs		.X	.015										.30
5	Outside Molding: 45P PVC, Black	15	g		.XX	.010										.10
4	Inside Molding: PE	5	g	.XXX	.005	.05	DRAWN BY	Hong		DATE	2019.01.14	1/1				
3	Red mere HDMI AM ABS Shell Color: Black	1	pcs	CHECK BY			APPD BY			DATE	2019.01.14	1/1				
2	HDMI (Type A) Extender with PCB	1	Set													
1	HDMI1.4~UL20276~[34AWG(7/0.06TC)+EAM]*5P+36AWG(7/0.05TC)*4C+AB(16/9/0.06 80%TC)OD:3.6MM Color: Black Marking: HIGH SPEED HDMI® CABLE WITH ETHERNET E342987 兄 AWM STYLE 20276 80°C 30V VW-1	L	M													
NO	DESCRIPTION	Q'TY	UNIT													