

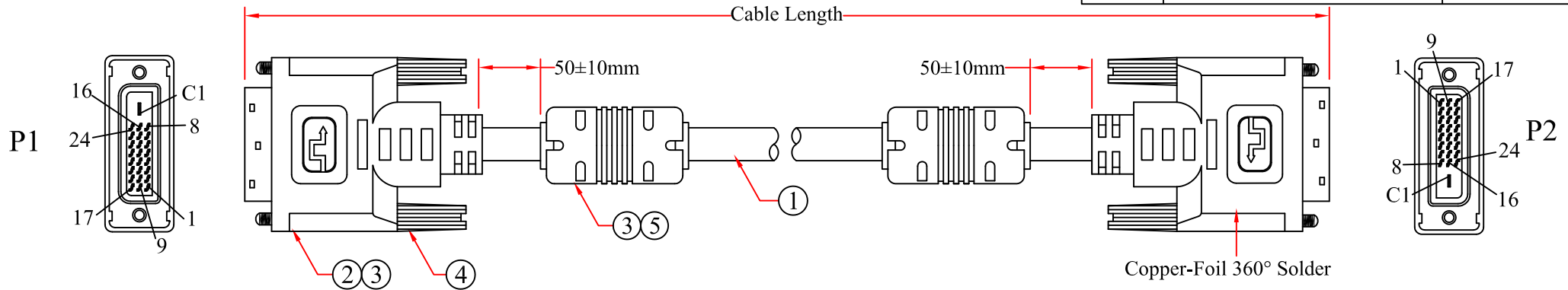

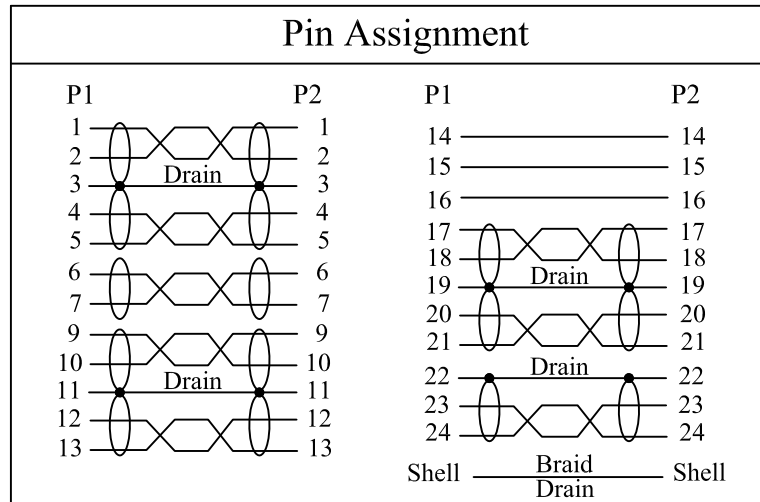

REV.	DESCRIPTION	DATE
B		12-2018

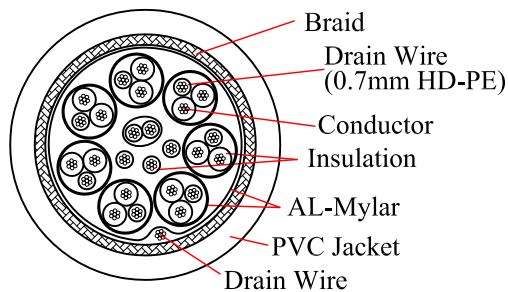

Cable Specifications

28AWG 7/0.127mm Stranded Tinned Copper
 AL-Mylar Foil Shield
 Tinned Copper Braid 16/10/0.12mm,85% Coverage
 1.0mm Foam PE(1P*7) and 0.7mm HD-PE(1P+3C) Insulation
 OD:7.3mm PVC Jacket

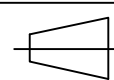

5	Ferrite Core	ITEM NUMBER	10V2-053xxBK-F		DRAWER	JL
4	#4-40 Molded Thumbscrew, Black Color	TITLE	DVI-D Dual Link Cable, DVI-D Male with Ferrite		CHECKED	
3	Molded PVC Hood, Black Color	MATERIAL	SCALE		APPROVED	
2	DVI (24+1)Pin Male, Insulation Black,Iron Shell Gold Plated	REV.	B	UNIT	INCH	 
1	DVI Cable 30AWG BC,[(1/0.23BC*1P+D1/0.23BC+AL/MY)*7Pcs+1/0.23BC*5C]+AL+D1/0.23BC+64/0.12AM, OD:6.5±0.15mm, Black PVC Jacket	DRAWING NO:				
NO.	SPECIFICATIONS	ID(NO.)	223			
BOM LIST						