

General Notes

- G01 The Design and Details shown in these Drawings are applicable to this Project only.
- G02 These Drawings shall be read in conjunction with all Architectural Drawings, other Consultants' Drawings, Specifications and such other Written Instructions as may be issued during the course of the Project. Any discrepancy shall be referred to the Engineer before proceeding with the work.
- G03 All Materials and Workmanship shall be in accordance with the relevant and current SAA Codes and Authorities Except where varied by the Project Specifications.
- G04 The Structure must be maintained in a stable condition and no part must be overloaded during construction. Temporary bracing must be designed and provided by the contractor(s) to keep the building works and excavations stable at all times.
- G05 The Issuer of these Designs reserves the right to alter Specifications and Designs as it may see fit without prior notification or penalty.
- G06 The Structure has not been designed for snow loads.

Foundation Notes

- F01 Foundations have been designed assuming an allowable bearing capacity of 100 kPa.
- F02 The Owner is advised to obtain a Geotechnical Report and/or Site Foundation Report to confirm F01 above.
- F03 Footings shall be located centrally under walls and columns unless noted otherwise.
- F04 All Footings to be founded a minimum of 400 mm into Natural Ground. Do not Found Footings in uncontrolled fill.
- F05 Engineer to be contacted if Foundation Conditions vary from F01 above.

Steelwork Notes

- S01 All Workmanship and Materials shall be in accordance with AS 4100, AS/NZ 4600 and AS 1554 except where varied by the Project documentation.
- S02 Bolting Categories are identified on the Structural Drawings in the following manner:
Bolt Category comments:
4.6/S Commercial Bolts of Grade 4.6 to AS 1111 Snug Tightened
8.8/S High Strength Structural Bolts of Grade 8.8 to AS 1252 Snug Tightened
- S03 Unless noted otherwise, all M16 fasteners shall be Category 8.8/S. Standard Fixings for C100, C150, C200 and C250 Sections are M12 bolts. Standard Fixings for C300 and C350 Section are M16 bolts. No Connection shall have less than 2 bolts.
- S04 All metal cladding should comply with AS1397-2001 G550, AZ150 (550 MPa minimum yield stress, 150 g/m2 minimum) coating mass.

- S05 Steelwork intended to be concrete encased shall be unpainted. Encasing concrete shall be Grade N25 unless noted otherwise providing a cover adequate to suit fire rating or exposure conditions. Concrete Encasement shall be centrally reinforced with 5 mm wire to AS 4671 or 6 mm Structural Grade Bars to AS 4671 at 150 mm pitch.
- S06 Unless noted otherwise, all steel shall be of the following grade in accordance with the relevant Australian Standard.

Type of Steel	Grade
Universal Beams & Columns, Parallel Flange Channels, Large Angles to AS/NZS3679.1	300 PLUS
Flats, Small Angles, Taper Flange Beams & Columns to AS/NZS3679.1	250
Welded Sections to AS/NZS3679.2	300
Hot Rolled Plates, Floor Plates & Slabs to AS/NZS3678	250
Hollow Sections to AS1163. Circular Sections less than 165mm Outside Diameter. Sections other than the above	250
Cold Form AS4600	G450

Australian Standard™ & Australian/New Zealand Standard™ Adopted

- AS 1111.1 ISO Metric Hexagon Bolts and Screws – Product Grade C Part 1: Bolts
- AS/NZS 1163 Cold-formed Structural Steel Hollow Sections
- AS/NZS 1170.0 Structural Design Actions - Part 0: General Principles
- AS/NZS 1170.1 Structural Design Actions - Part 1: Permanent, Imposed & Other Actions
- AS/NZS 1170.2 Structural Design Actions - Part 2: Structural Design, Wind Actions
- AS/NZS 1170.4 Structural Design Actions - Part 4: Earthquake Actions in Australia
- AS 1252 Structural Assemblies
- AS 1397 Continuous Hot-dip Metallic Coated Steel Sheet & Strip
- AS/NZS 1554 Structural Steel Welding
- AS 4100 Steel Structures
- AS/NZS 4600 Cold-formed Steel Structures
- AS/NZS 4671 Steel Reinforcing Materials
- AS/NZS 4680 Hot-dip Galvanized (Zinc) Coatings on Fabricated Ferrous Articles

Design Notes

Dimensions	8000 x 6000 x 2600
Region	A
Design Wind Speed	37.35 m/s
Columns (C)	100x100x2 Grade C450L0
Rafters (R)	C25024 G450
Purlins (P)	C15019 G450
Fascia Beams (FB)	C25019 G450
Purlin Bridging	TH22x0.4
Footings	Cast In
All Brackets	3 mm G450
Max Rafter Moment	R1 at 16.66 kNm
Max Rafter Deflection	R1 at 21.95 mm
Max Purlin Deflection	P1.2 at 12.84 mm
Max Column Uplift	C1.1 at 8.88 kN
Max Column Moment	C1.2 at 4.84 kNm

This is a freestanding roof only structure. It is assumed that cars, goods or materials stored under the roof block less than 75 percentage of the cross section exposed to the wind.

Suitable for Region A, TC3 without Shielding: Terrain with numerous closely spaced obstructions from 3 to 5 meters high. A building that has no protection from wind in the immediate area.

$$V_{design} = V_R \times M_d \times M_s \times M_t \times M_{z,Cat}$$

$$V_{design} = 45.0 \times 1 \times 1.0 \times 1 \times 0.83 = 37.35 \text{ m/s}$$

Site Description: A typical suburban or well developed industrial area. A building is on the outer circle & at least one side of the building has no protection from wind.

Foundations have been designed assuming an allowable bearing capacity of 100 kPa, undrained cohesion $C_u = 20$ kPa. Concrete Strength = 25 MPa.

MANUFACTURED IN AUSTRALIA FOR



PROJECT:
8000 x 6000 x 2600

CLIENT:

ADDRESS:

PROJECT NUMBER:
1767

DRAWN BY:

DRAWN DATE:
2020-08-05

© 2020 dm3 Solutions. The Information contained herein is Proprietary, Confidential and the Sole Property of dm3 Solutions. Reproduction in part or in whole is Prohibited without written approval. Unless specified otherwise, dimensions are in millimetres & drawings are not to scale.

Powered by dm3Solutions.com

ISSUE:	SIZE:	SCALE:	DRAWING NUMBER
1	A4	NTS	1 of 18

Low Side Elevation

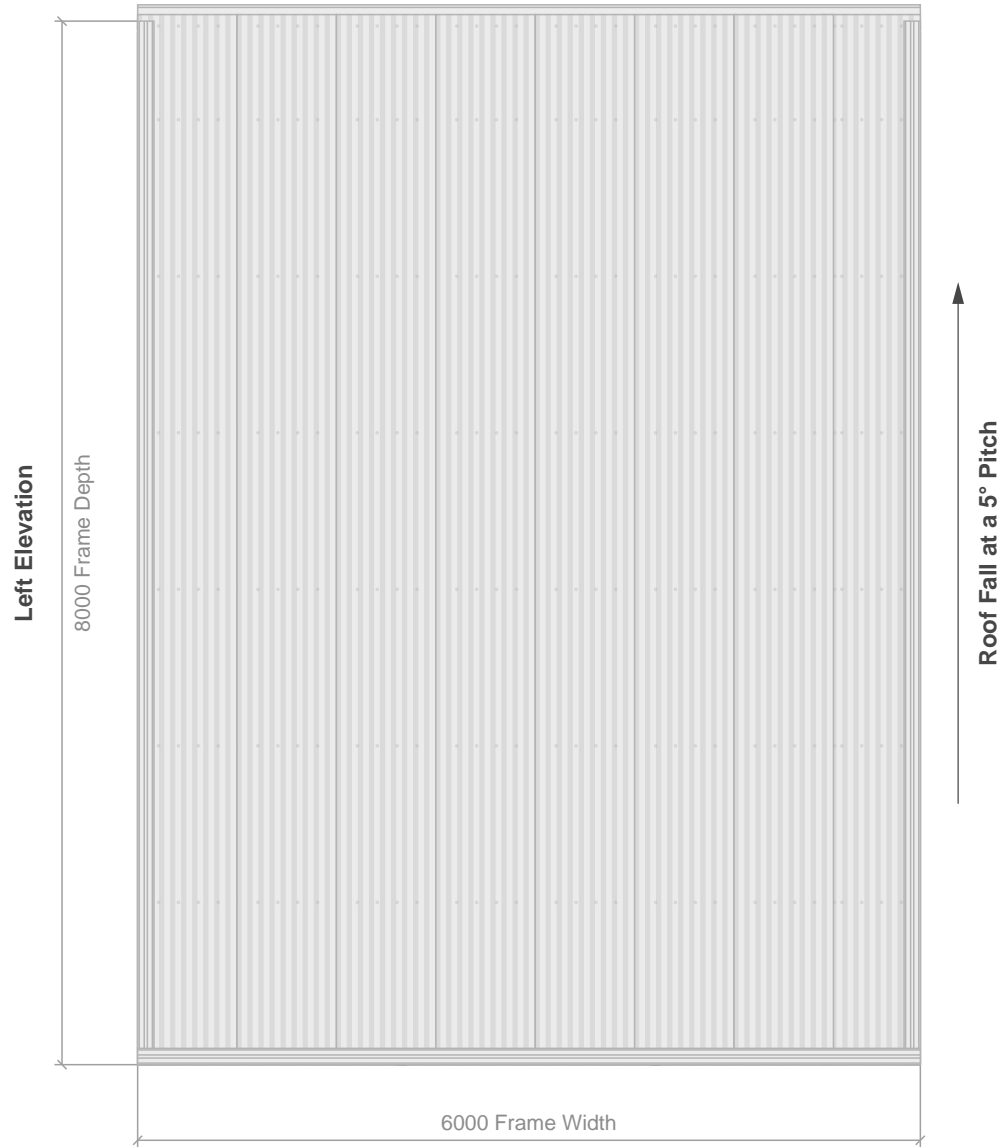

Note: Roof structure has been designed to support solar panels not exceeding 20 kg per m2

<p>MANUFACTURED IN AUSTRALIA FOR</p> <p>CAR COVERS AND SHELTER</p> <p>PROFESSIONAL CHOICE SOLAR-READY CARPORTS</p>	<p>PROJECT: 8000 x 6000 x 2600</p>	<p>PROJECT NUMBER: 1767</p>	<p>© 2020 dm3 Solutions. The Information contained herein is Proprietary, Confidential and the Sole Property of dm3 Solutions. Reproduction in part or in whole is Prohibited without written approval. Unless specified otherwise, dimensions are in millimetres & drawings are not to scale.</p> <p>Powered by dm3Solutions.com</p>			
	<p>CLIENT:</p>	<p>DRAWN BY: dm3 Solutions</p>	<p>ISSUE: 1</p>	<p>SIZE: A4</p>	<p>SCALE: NTS</p>	<p>DRAWING NUMBER 2 of 18</p>
	<p>ADDRESS:</p>	<p>DRAWN DATE: 2020-08-05</p>				

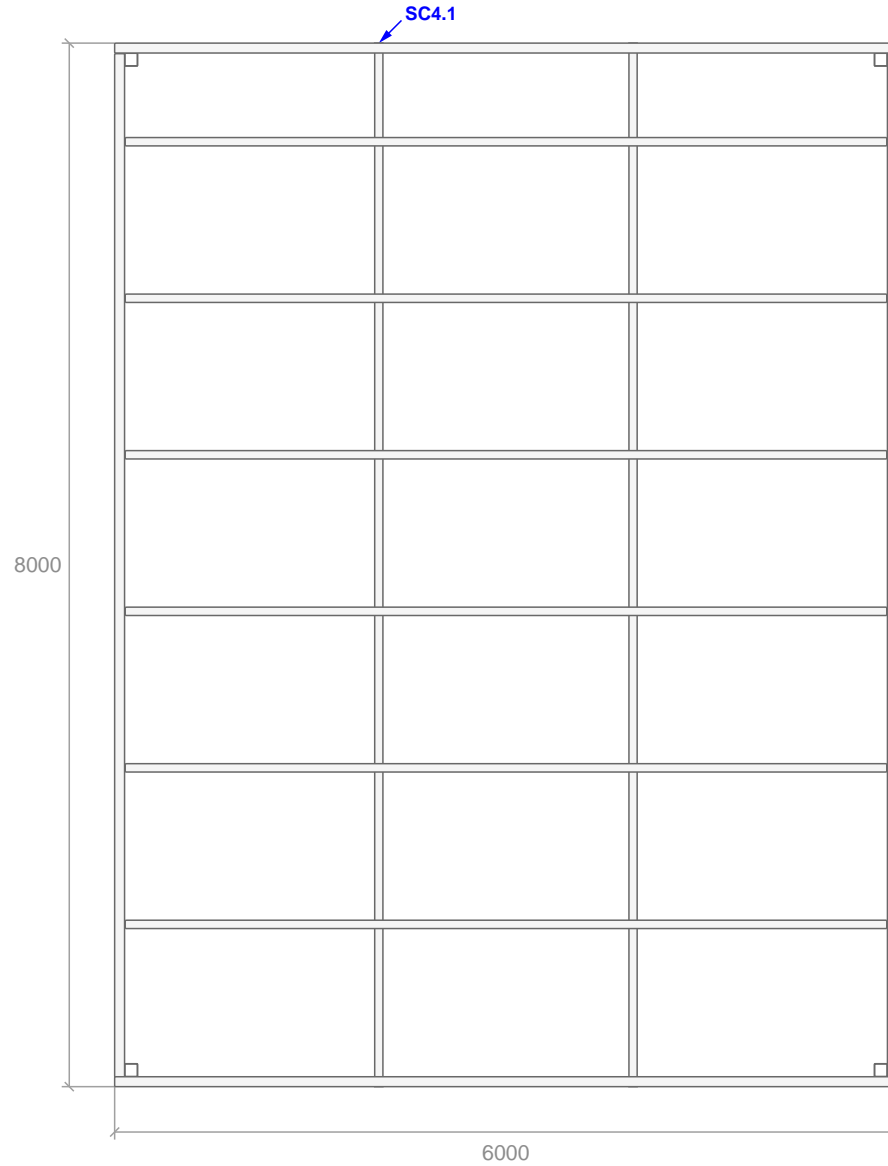

MANUFACTURED IN AUSTRALIA
FOR



PROJECT:
8000 x 6000 x 2600

CLIENT:
[REDACTED]

ADDRESS:
[REDACTED]

PROJECT NUMBER:
1767

DRAWN BY:
[REDACTED]

DRAWN DATE:
2020-08-05

© 2020 dm3 Solutions. The Information contained herein is Proprietary, Confidential and the Sole Property of dm3 Solutions. Reproduction in part or in whole is Prohibited without written approval. Unless specified otherwise, dimensions are in millimetres & drawings are not to scale.

Powered by dm3Solutions.com

ISSUE:	SIZE:	SCALE:	DRAWING NUMBER
1	A4	NTS	3 of 18

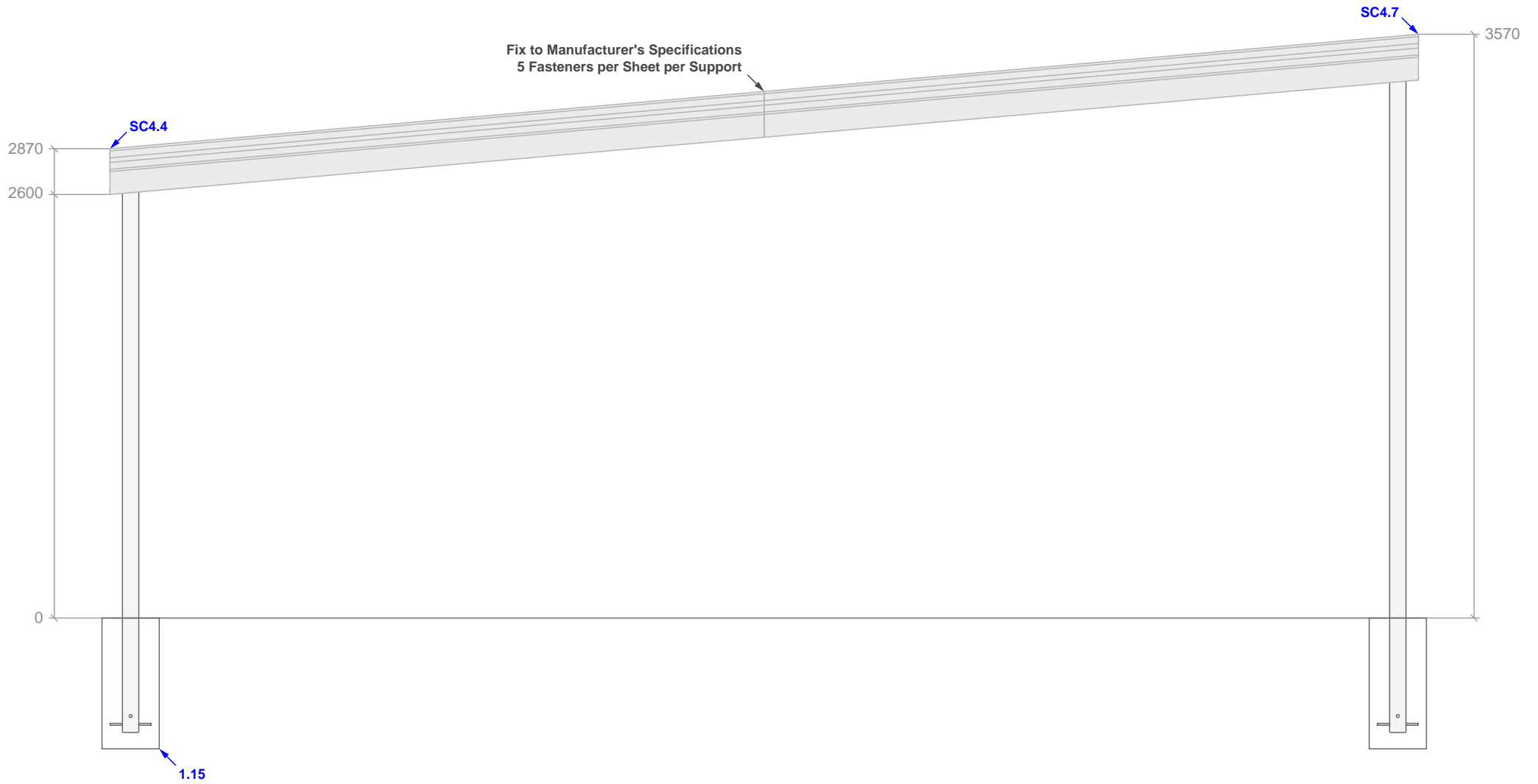

MANUFACTURED IN AUSTRALIA
FOR



PROJECT: 8000 x 6000 x 2600
CLIENT:
ADDRESS:

PROJECT NUMBER: 1767
DRAWN BY:
DRAWN DATE: 2020-08-05

© 2020 dm3 Solutions. The Information contained herein is Proprietary, Confidential and the Sole Property of dm3 Solutions. Reproduction in part or in whole is Prohibited without written approval. Unless specified otherwise, dimensions are in millimetres & drawings are not to scale.			
Powered by dm3Solutions.com			
ISSUE: 1	SIZE: A4	SCALE: NTS	DRAWING NUMBER 4 of 18



MANUFACTURED IN AUSTRALIA
FOR

**CAR COVERS
AND SHELTER**

PROFESSIONAL CHOICE
SOLAR-READY CARPORTS

PROJECT: 8000 x 6000 x 2600
CLIENT:
ADDRESS:

PROJECT NUMBER: 1767
DRAWN BY:
DRAWN DATE: 2020-08-05

© 2020 dm3 Solutions. The Information contained herein is Proprietary, Confidential and the Sole Property of dm3 Solutions. Reproduction in part or in whole is Prohibited without written approval. Unless specified otherwise, dimensions are in millimetres & drawings are not to scale.			
Powered by dm3Solutions.com			
ISSUE: 1	SIZE: A4	SCALE: NTS	DRAWING NUMBER 5 of 18

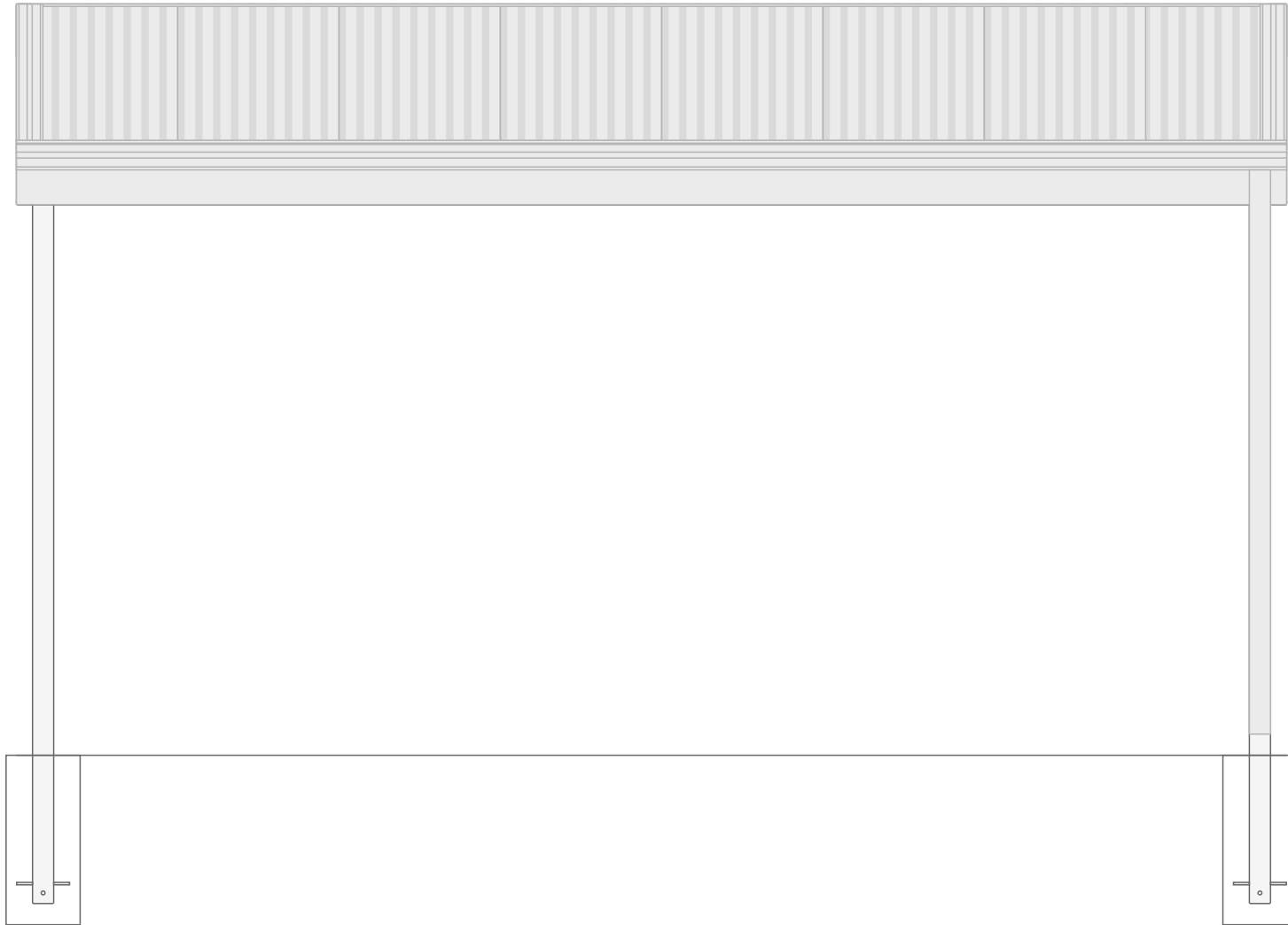

MANUFACTURED IN AUSTRALIA
FOR



PROJECT:
8000 x 6000 x 2600

CLIENT:

ADDRESS:

PROJECT NUMBER:
1767

DRAWN BY:

DRAWN DATE:
2020-08-05

© 2020 dm3 Solutions. The Information contained herein is Proprietary, Confidential and the Sole Property of dm3 Solutions. Reproduction in part or in whole is Prohibited without written approval. Unless specified otherwise, dimensions are in millimetres & drawings are not to scale.

Powered by dm3solutions.com

ISSUE:
1

SIZE:
A4

SCALE:
NTS

DRAWING NUMBER
6 of 18

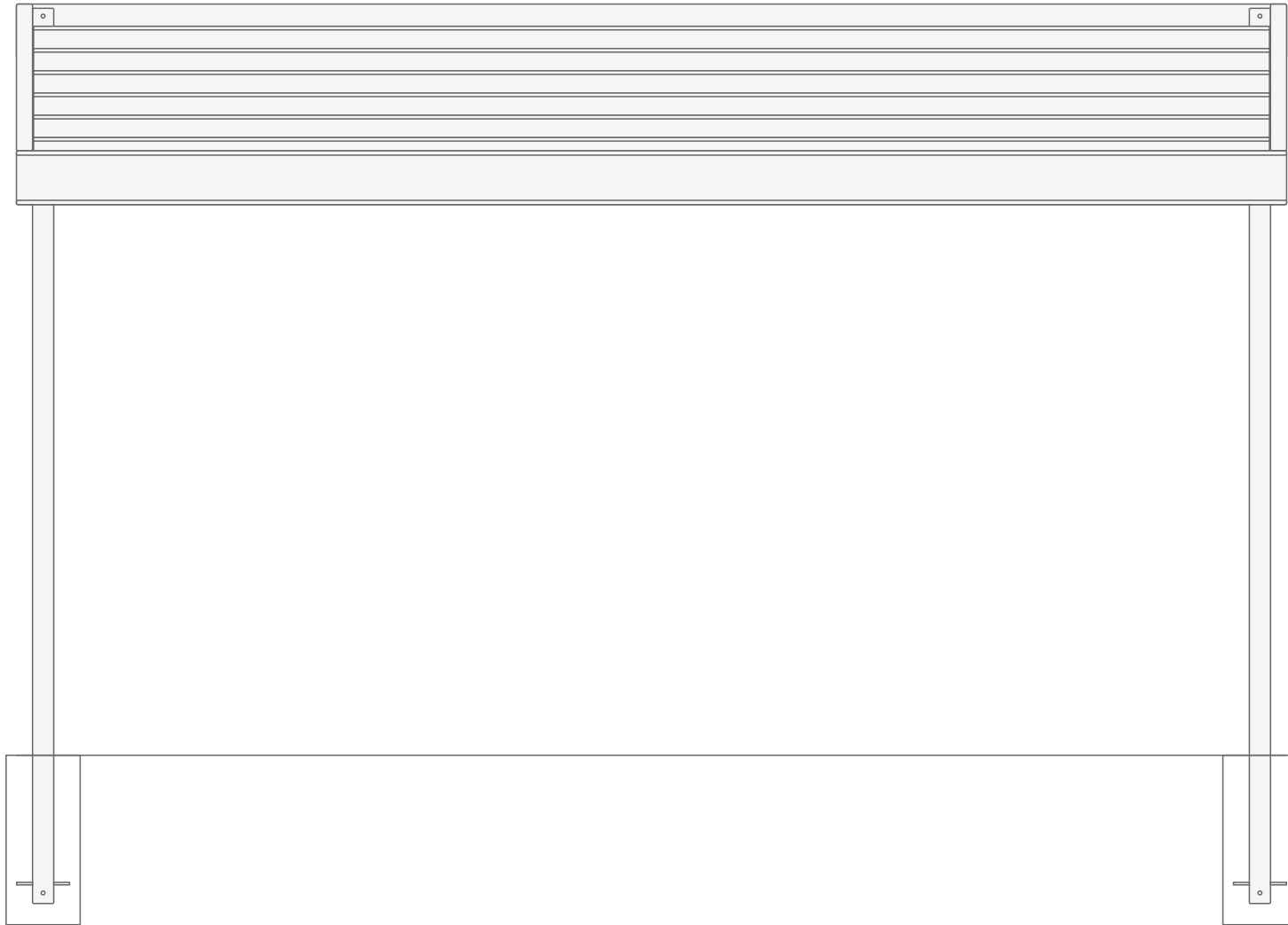

MANUFACTURED IN AUSTRALIA
FOR



PROFESSIONAL CHOICE
SOLAR-READY CARPORTS

PROJECT:
8000 x 6000 x 2600

CLIENT:
[Redacted]

ADDRESS:
[Redacted]

PROJECT NUMBER:
1767

DRAWN BY:
[Redacted]

DRAWN DATE:
2020-08-05

© 2020 dm3 Solutions. The Information contained herein is Proprietary, Confidential and the Sole Property of dm3 Solutions. Reproduction in part or in whole is Prohibited without written approval. Unless specified otherwise, dimensions are in millimetres & drawings are not to scale.

Powered by dm3solutions.com

ISSUE: 1	SIZE: A4	SCALE: NTS	DRAWING NUMBER: 7 of 18
-------------	-------------	---------------	----------------------------

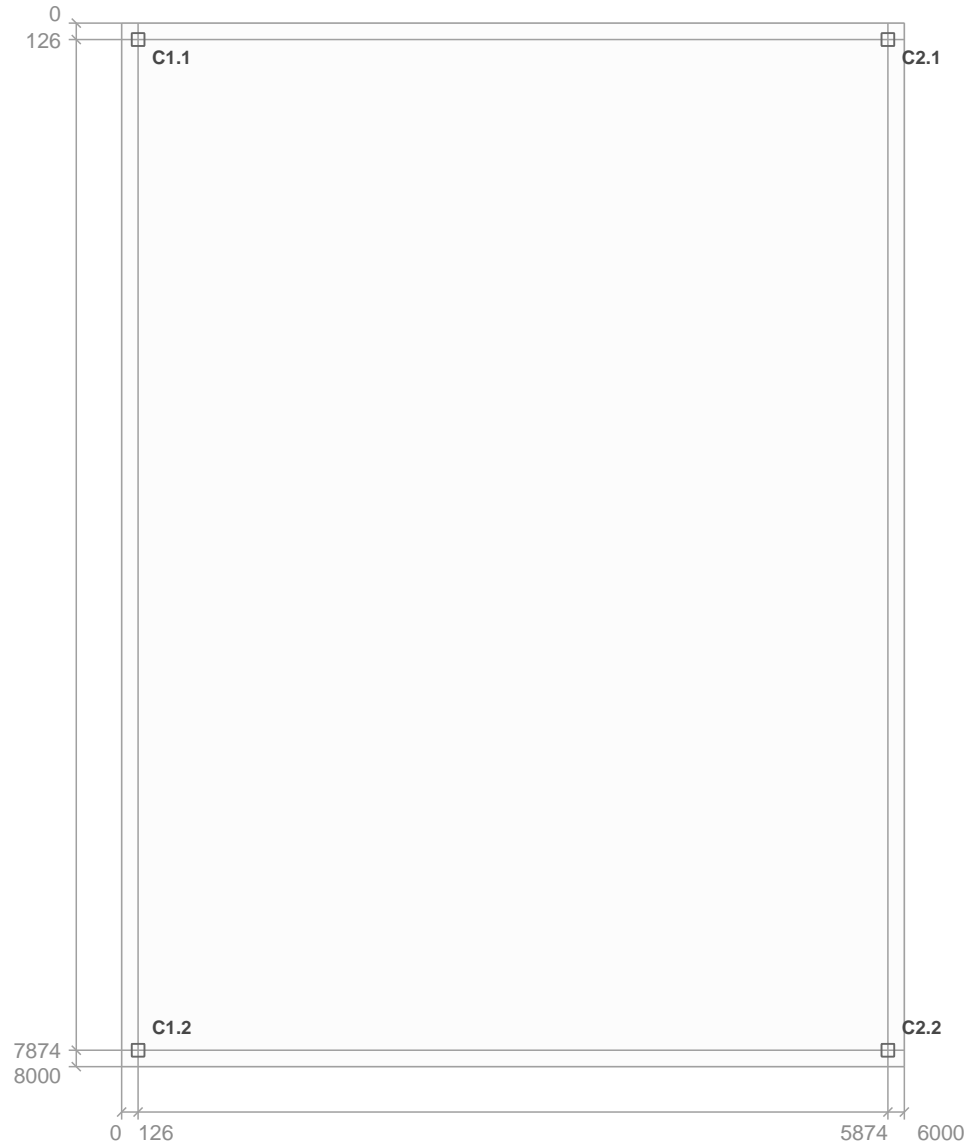

MANUFACTURED IN AUSTRALIA
FOR



PROJECT:
8000 x 6000 x 2600

CLIENT:
-

ADDRESS:
1111 Street, Downm...

PROJECT NUMBER:
1767

DRAWN BY:
-

DRAWN DATE:
2020-08-05

© 2020 dm3 Solutions. The Information contained herein is Proprietary, Confidential and the Sole Property of dm3 Solutions. Reproduction in part or in whole is Prohibited without written approval. Unless specified otherwise, dimensions are in millimetres & drawings are not to scale.

Powered by dm3solutions.com

ISSUE:	SIZE:	SCALE:	DRAWING NUMBER
1	A4	NTS	8 of 18

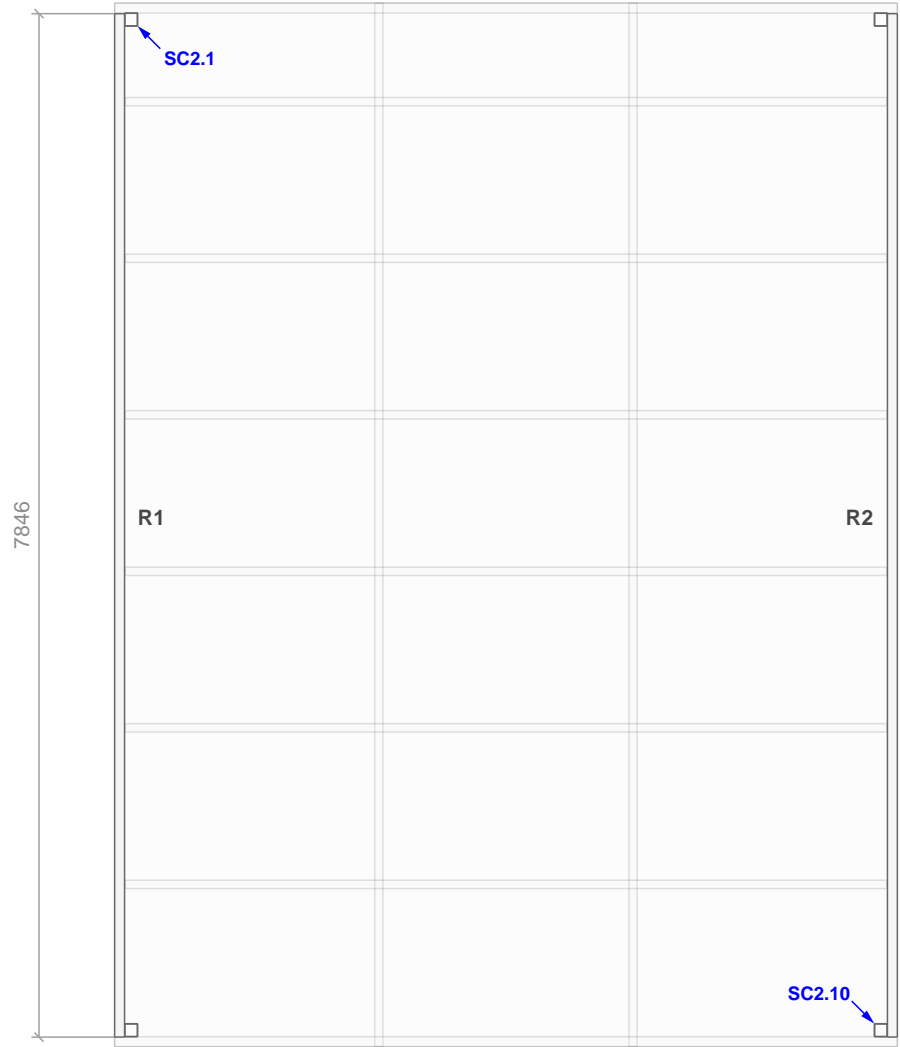

MANUFACTURED IN AUSTRALIA
FOR



PROJECT:
8000 x 6000 x 2600

CLIENT:

ADDRESS:

PROJECT NUMBER:
1767

DRAWN BY:

DRAWN DATE:
2020-08-05

© 2020 dm3 Solutions. The Information contained herein is Proprietary, Confidential and the Sole Property of dm3 Solutions. Reproduction in part or in whole is Prohibited without written approval. Unless specified otherwise, dimensions are in millimetres & drawings are not to scale.

Powered by dm3Solutions.com

ISSUE:	SIZE:	SCALE:	DRAWING NUMBER
1	A4	NTS	9 of 18

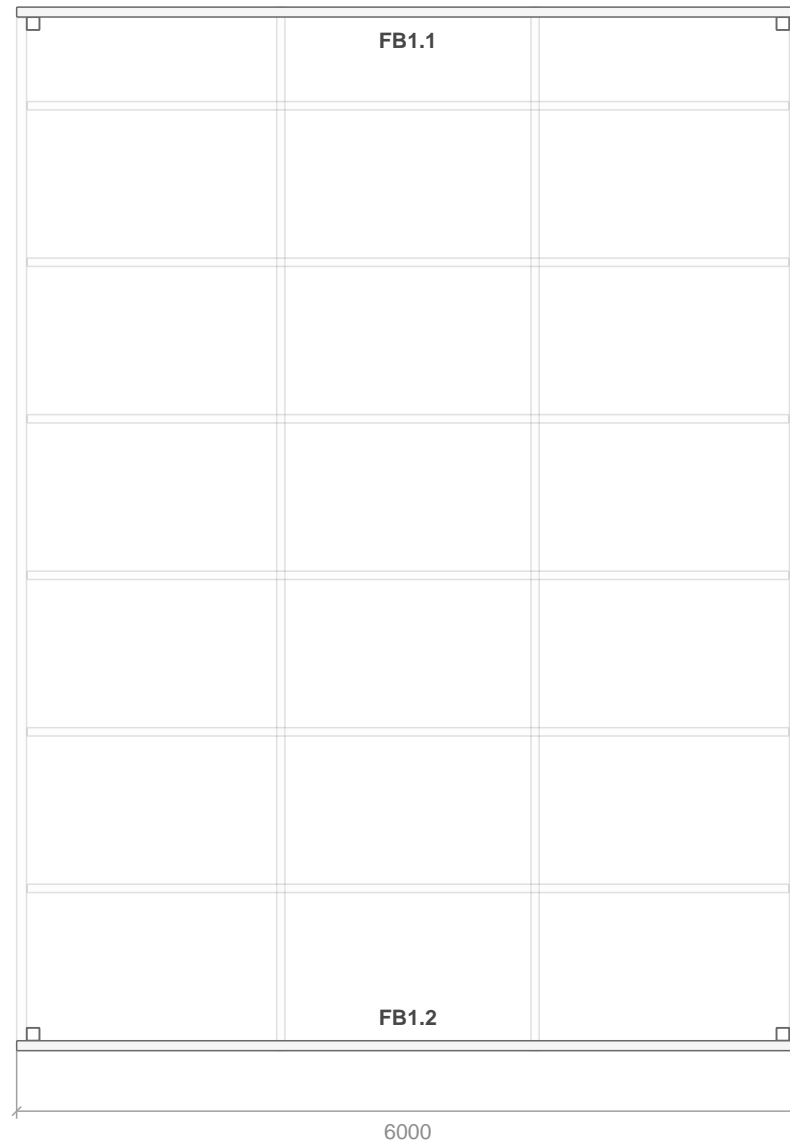

MANUFACTURED IN AUSTRALIA
FOR



PROJECT:
8000 x 6000 x 2600

CLIENT:
-

ADDRESS:
-

PROJECT NUMBER:
1767

DRAWN BY:

DRAWN DATE:
2020-08-05

© 2020 dm3 Solutions. The Information contained herein is Proprietary, Confidential and the Sole Property of dm3 Solutions. Reproduction in part or in whole is Prohibited without written approval. Unless specified otherwise, dimensions are in millimetres & drawings are not to scale.

Powered by dm3Solutions.com

ISSUE:	SIZE:	SCALE:	DRAWING NUMBER
1	A4	NTS	10 of 18

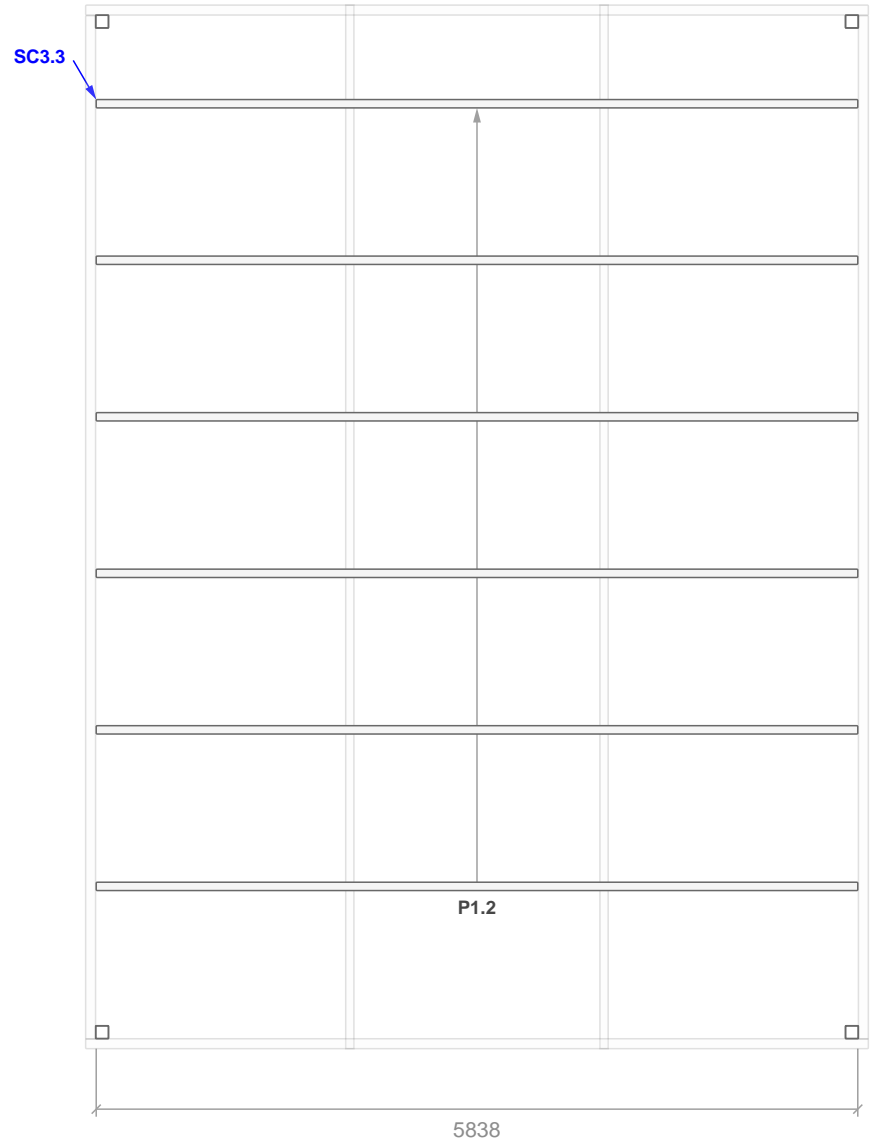

Detail 1.15: Footings



Scan for Video

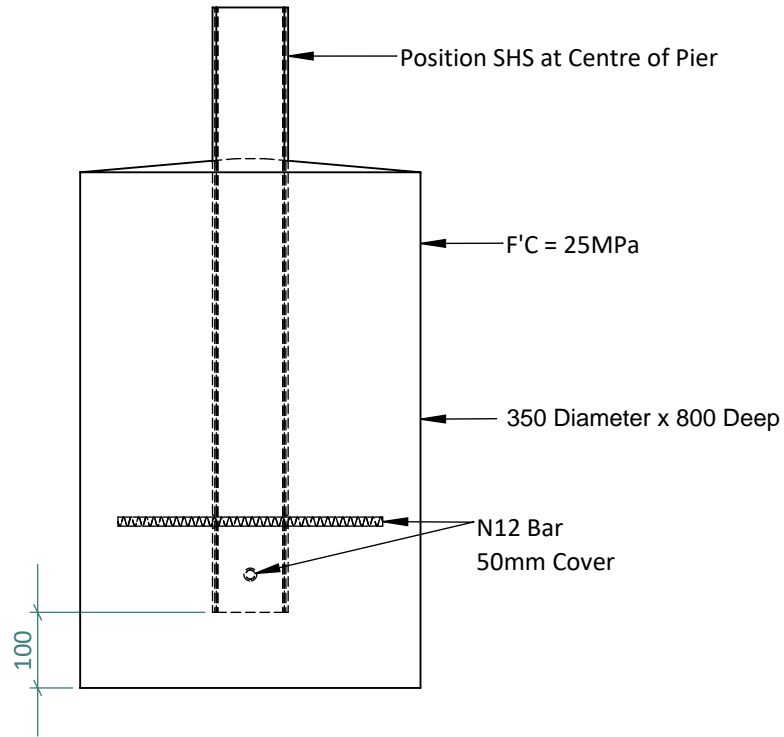

ELEVATION

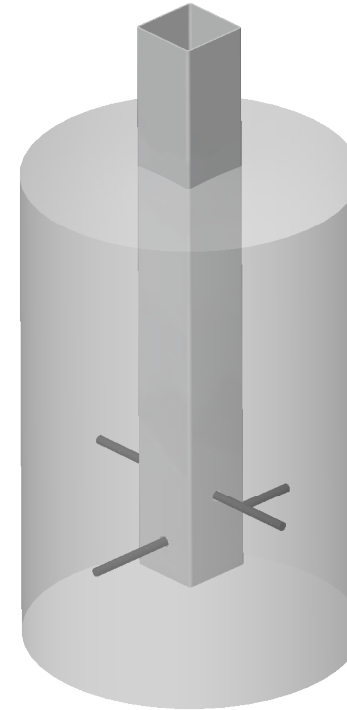

ISOMETRIC

MANUFACTURED IN AUSTRALIA
FOR



PROJECT:
8000 x 6000 x 2600

CLIENT:

ADDRESS:

PROJECT NUMBER:
1767

DRAWN BY:

DRAWN DATE:
2020-08-05

© 2020 dm3 Solutions. The Information contained herein is Proprietary, Confidential and the Sole Property of dm3 Solutions. Reproduction in part or in whole is Prohibited without written approval. Unless specified otherwise, dimensions are in millimetres & drawings are not to scale.

Powered by dm3solutions.com

ISSUE: 1	SIZE: A4	SCALE: NTS	DRAWING NUMBER 12 of 18
-------------	-------------	---------------	----------------------------

Detail SC2.1: Rafters



Scan for Video

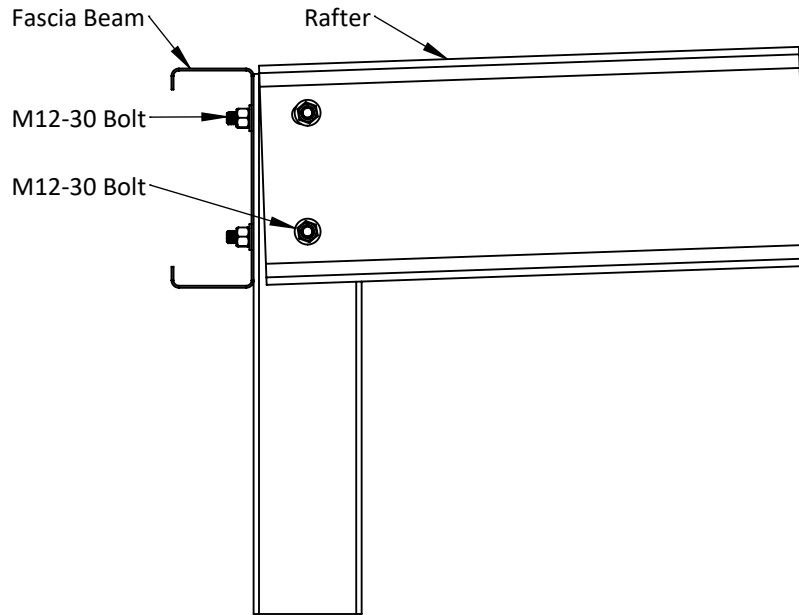

ELEVATION

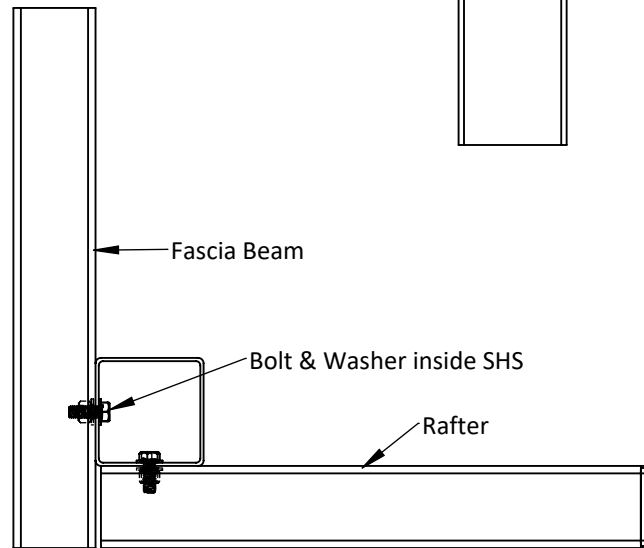

PLAN

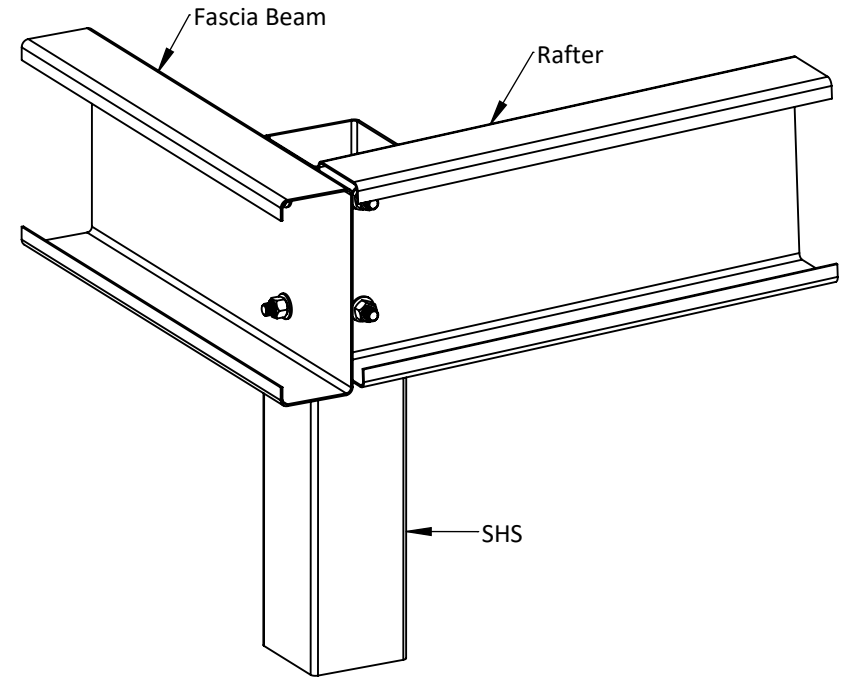

ISOMETRIC

MANUFACTURED IN AUSTRALIA
FOR



PROFESSIONAL CHOICE
SOLAR-READY CARPORTS

PROJECT:
8000 x 6000 x 2600

CLIENT:

ADDRESS:

PROJECT NUMBER:
1767

DRAWN BY:

DRAWN DATE:
2020-08-05

© 2020 dm3 Solutions. The Information contained herein is Proprietary, Confidential and the Sole Property of dm3 Solutions. Reproduction in part or in whole is Prohibited without written approval. Unless specified otherwise, dimensions are in millimetres & drawings are not to scale.

Powered by [dm3Solutions.com](https://www.dm3solutions.com)

ISSUE:	SIZE:	SCALE:	DRAWING NUMBER
1	A4	NTS	13 of 18

Detail SC2.10: Rafters



Scan for Video

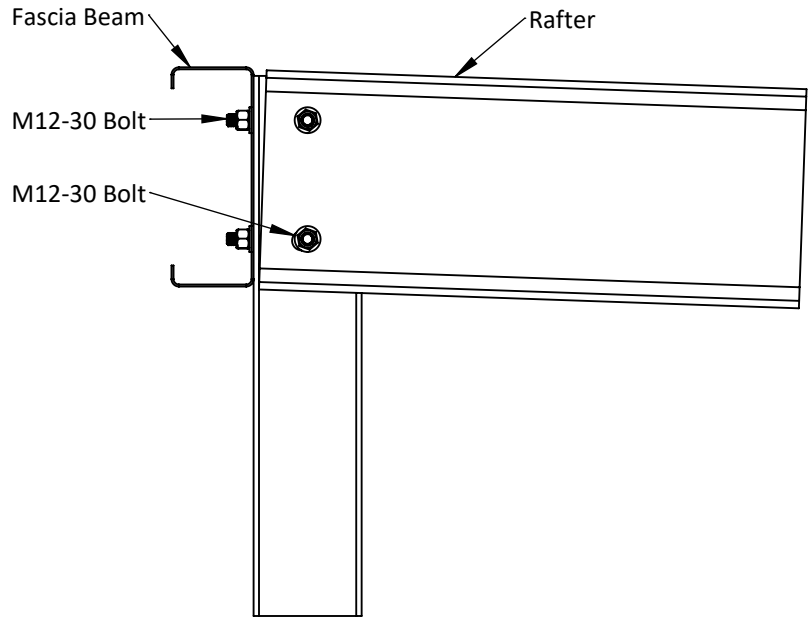

ELEVATION

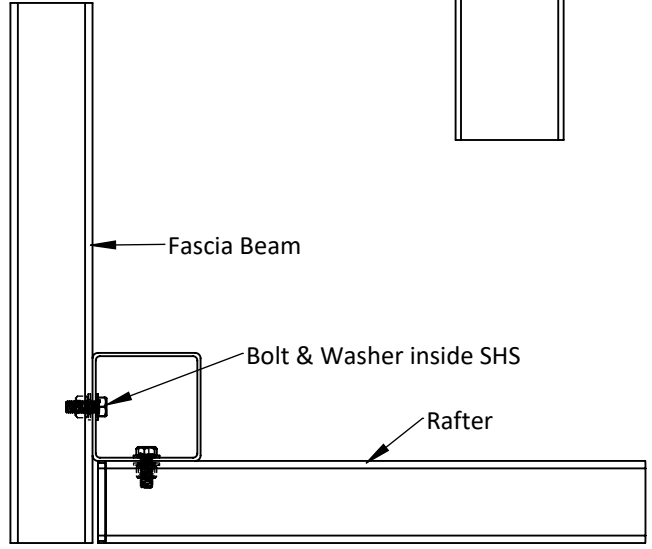

PLAN

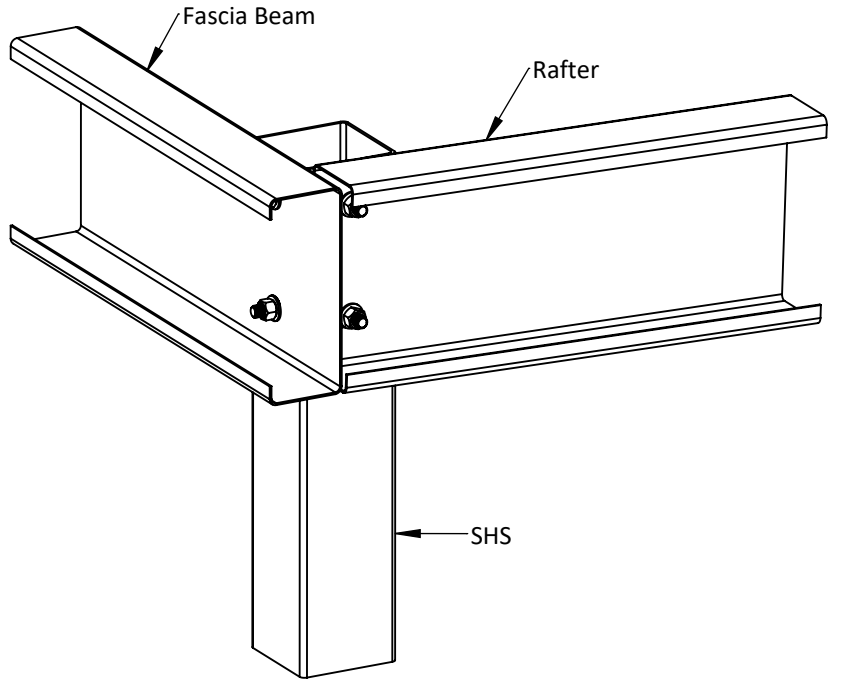

ISOMETRIC

MANUFACTURED IN AUSTRALIA FOR

CAR COVERS AND SHELTER

PROFESSIONAL CHOICE SOLAR-READY CARPORTS

PROJECT: 8000 x 6000 x 2600
CLIENT: [Redacted]
ADDRESS: [Redacted]

PROJECT NUMBER: 1767
DRAWN BY: [Redacted]
DRAWN DATE: 2020-08-05

© 2020 dm3 Solutions. The Information contained herein is Proprietary, Confidential and the Sole Property of dm3 Solutions. Reproduction in part or in whole is Prohibited without written approval. Unless specified otherwise, dimensions are in millimetres & drawings are not to scale.			
Powered by dm3Solutions.com			
ISSUE: 1	SIZE: A4	SCALE: NTS	DRAWING NUMBER 14 of 18

Detail SC3.3: Purlin To Rafter Web



Scan for Video

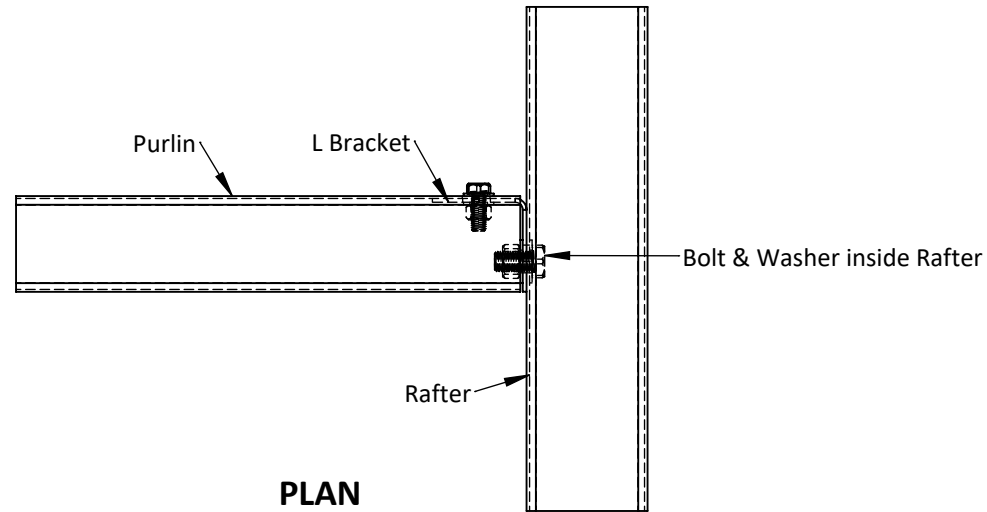

PLAN

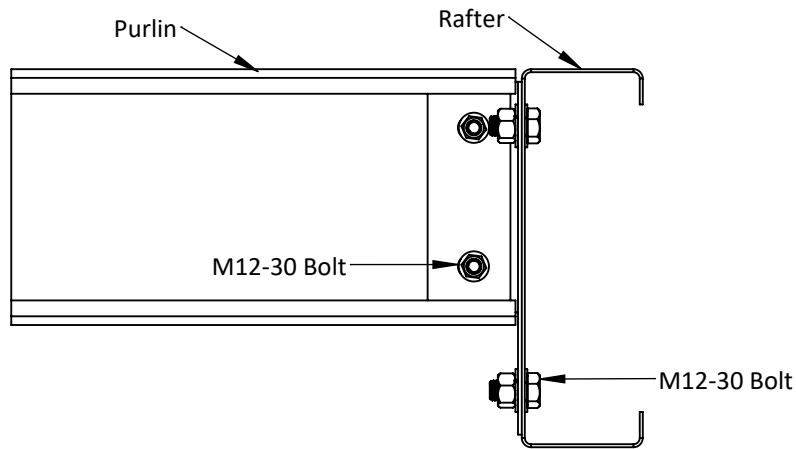

ELEVATION

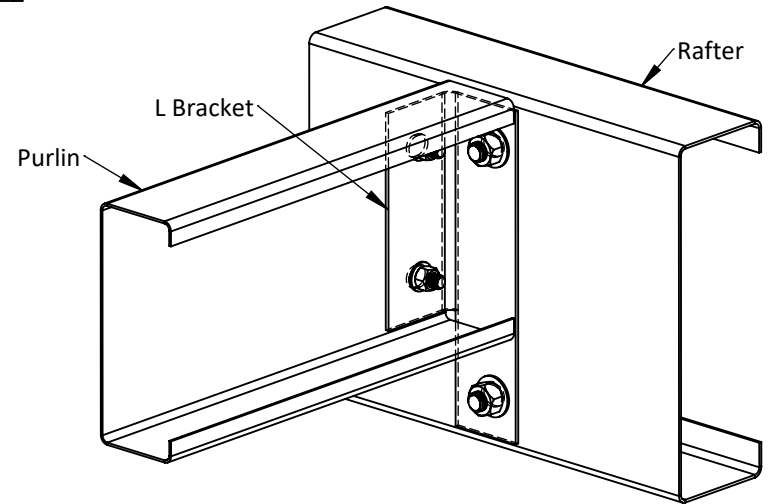

ISOMETRIC

MANUFACTURED IN AUSTRALIA
FOR

**CAR COVERS
AND SHELTER**

PROFESSIONAL CHOICE
SOLAR-READY CARPORTS

PROJECT: 8000 x 6000 x 2600	PROJECT NUMBER: 1767
CLIENT: Edwards	DRAWN BY: [Redacted]
ADDRESS: [Redacted]	DRAWN DATE: 2020-08-05

© 2020 dm3 Solutions. The Information contained herein is Proprietary, Confidential and the Sole Property of dm3 Solutions. Reproduction in part or in whole is Prohibited without written approval. Unless specified otherwise, dimensions are in millimetres & drawings are not to scale.			
Powered by dm3Solutions.com			
ISSUE: 1	SIZE: A4	SCALE: NTS	DRAWING NUMBER: 15 of 18

Detail SC4.1: Purlin Bridging



Scan for Video

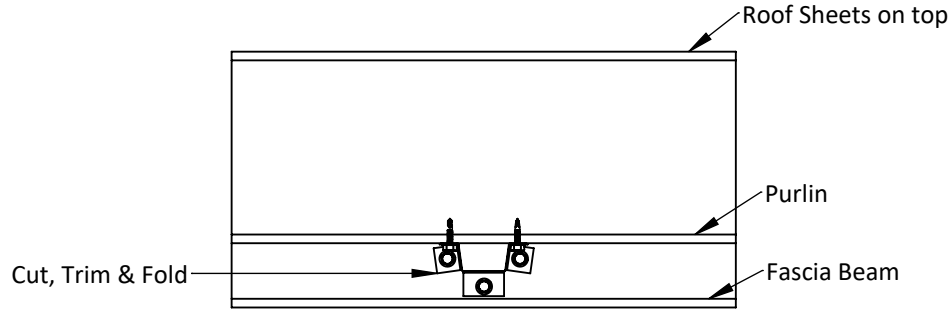

ELEVATION

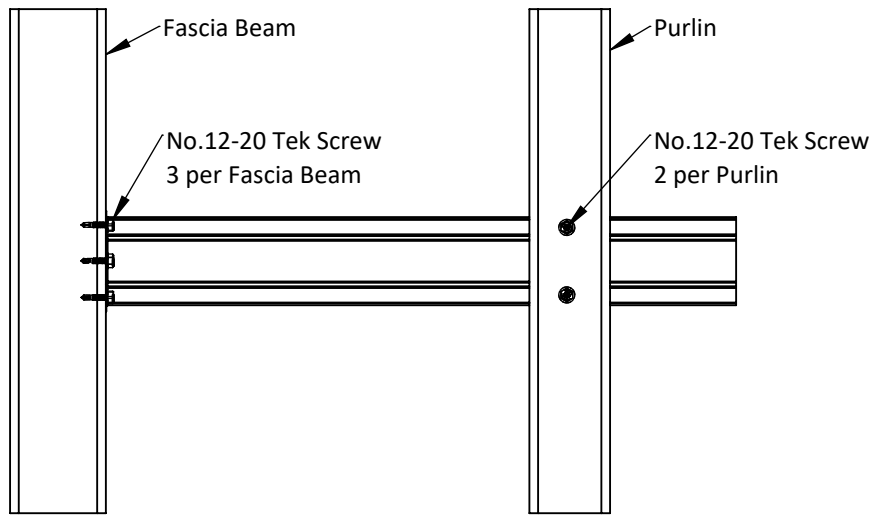

PLAN

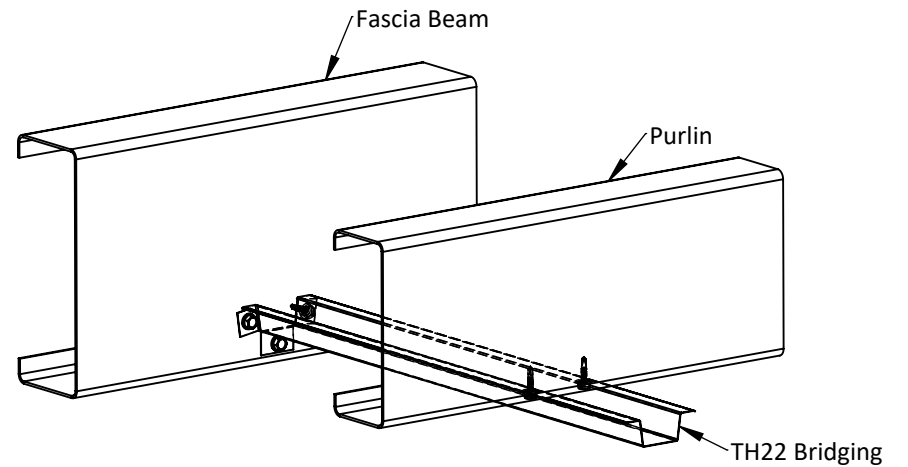

ISOMETRIC

MANUFACTURED IN AUSTRALIA
FOR

**CAR COVERS
AND SHELTER**

PROFESSIONAL CHOICE
SOLAR-READY CARPORTS

PROJECT: 8000 x 6000 x 2600	PROJECT NUMBER: 1767
CLIENT:	DRAWN BY:
ADDRESS:	DRAWN DATE: 2020-08-05

© 2020 dm3 Solutions. The Information contained herein is Proprietary, Confidential and the Sole Property of dm3 Solutions. Reproduction in part or in whole is Prohibited without written approval. Unless specified otherwise, dimensions are in millimetres & drawings are not to scale.			
Powered by dm3Solutions.com			
ISSUE: 1	SIZE: A4	SCALE: NTS	DRAWING NUMBER 16 of 18

Detail SC4.4: Roof Sheet & Flashing



Scan for Video

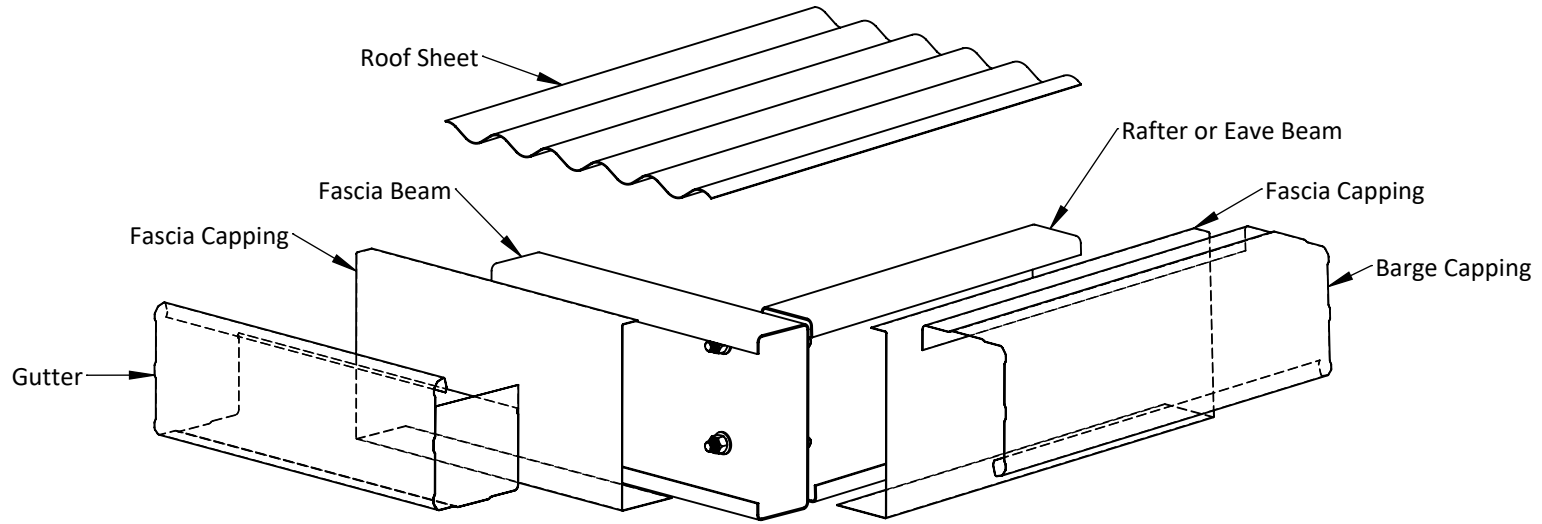

EXPLODED VIEW

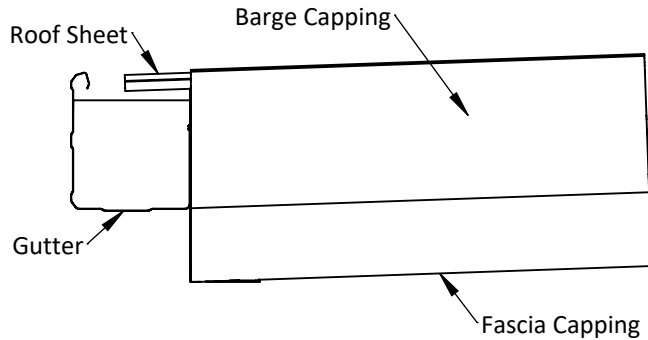

ELEVATION

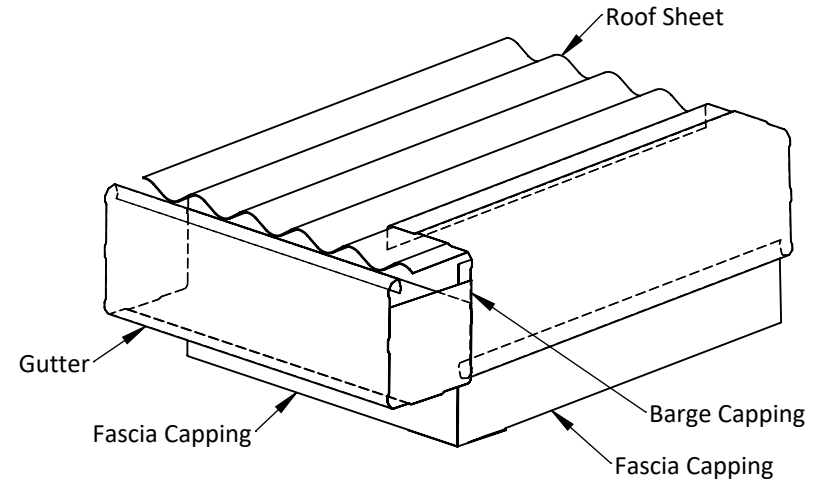

ISOMETRIC

MANUFACTURED IN AUSTRALIA
FOR



PROFESSIONAL CHOICE
SOLAR-READY CARPORTS

PROJECT:
8000 x 6000 x 2600

CLIENT:

ADDRESS:

PROJECT NUMBER:
1767

DRAWN BY:

DRAWN DATE:
2020-08-05

© 2020 dm3 Solutions. The Information contained herein is Proprietary, Confidential and the Sole Property of dm3 Solutions. Reproduction in part or in whole is Prohibited without written approval. Unless specified otherwise, dimensions are in millimetres & drawings are not to scale.

Powered by [dm3Solutions.com](https://www.dm3solutions.com)

ISSUE: 1	SIZE: A4	SCALE: NTS	DRAWING NUMBER 17 of 18
-------------	-------------	---------------	----------------------------

Detail SC4.7: Roof Sheet & Flashing



Scan for Video

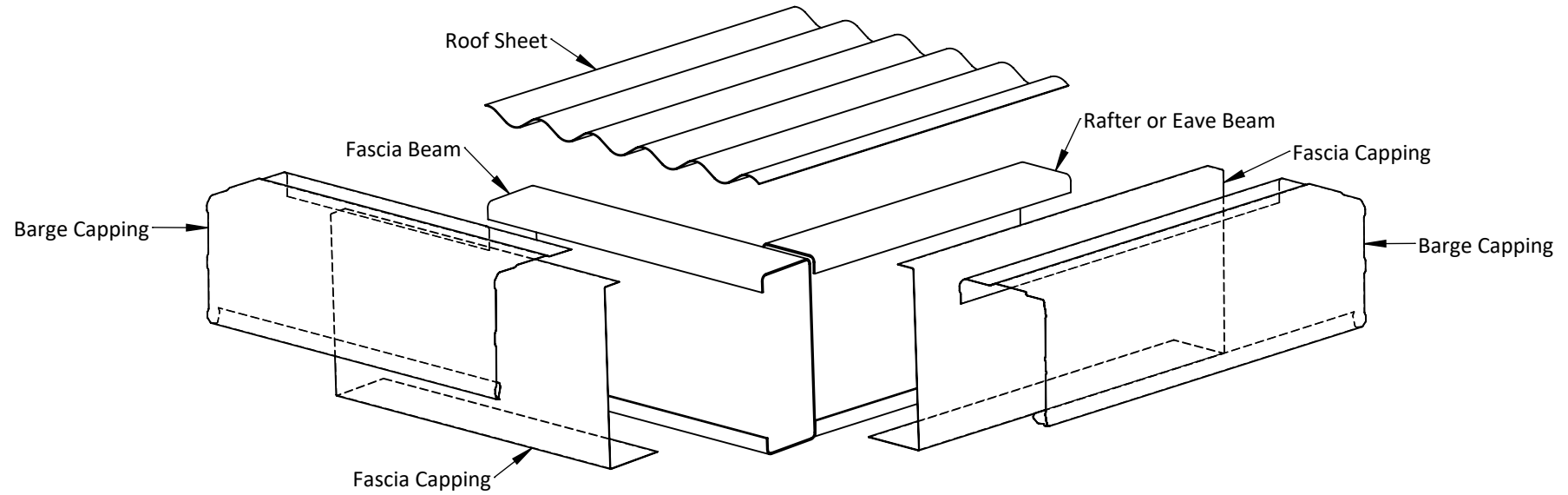

EXPLODED VIEW

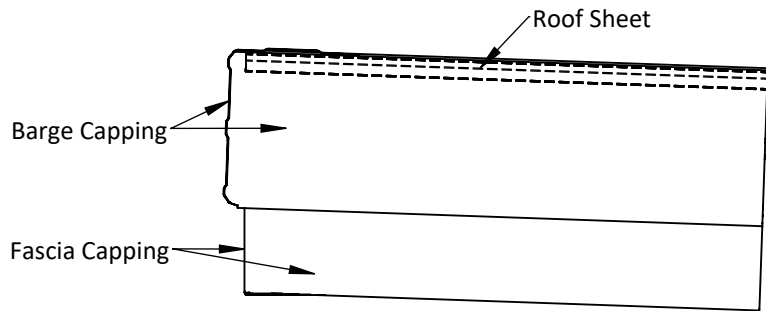

ELEVATION

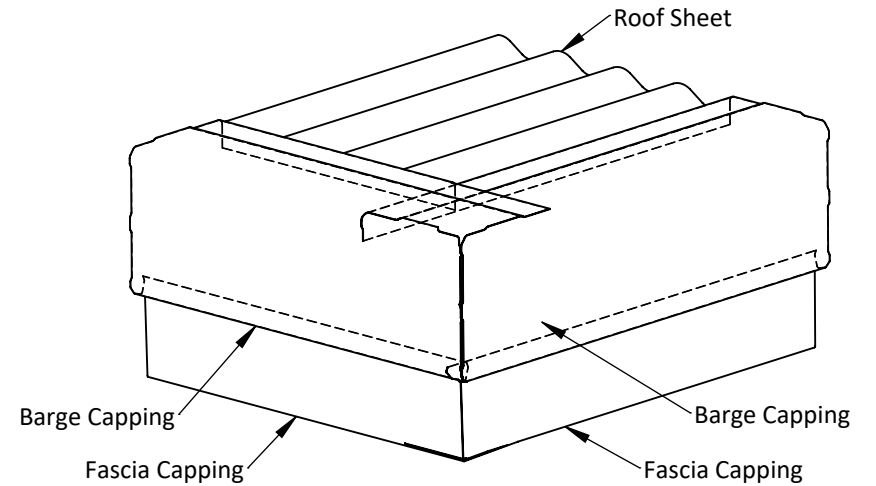

ISOMETRIC

MANUFACTURED IN AUSTRALIA
FOR



PROFESSIONAL CHOICE
SOLAR-READY CARPORTS

PROJECT:
8000 x 6000 x 2600

CLIENT:

ADDRESS:

PROJECT NUMBER:
1767

DRAWN BY:

DRAWN DATE:
2020-08-05

© 2020 dm3 Solutions. The Information contained herein is Proprietary, Confidential and the Sole Property of dm3 Solutions. Reproduction in part or in whole is Prohibited without written approval. Unless specified otherwise, dimensions are in millimetres & drawings are not to scale.

Powered by dm3Solutions.com

ISSUE: 1	SIZE: A4	SCALE: NTS	DRAWING NUMBER: 18 of 18
-------------	-------------	---------------	-----------------------------