

SPO5L2SDL

Family	Ovens
Subfamily	Combi steamer oven 5 trays GN1/1
Oven type	Convection with fan- Humidified - With EBT technology - Trivalent combisteamer
Trays capacity	5 trays GN1/1
Power supply	400 V 3N~ / 17 A / 8 kW / 50-60 Hz
Steam generation	Direct and Open boiler
Maximum depth with open door	1623 mm
Adjustable feet	Yes
Net weight	90,000 kg
Product dimensions WxDxH	790x875x645 mm



Distribution

Solutions	Hotels; Restaurants/Catering; Bakery/Pastry making; Industrial pastry&bakery laboratories; Butcher's shops; Hospitals; Schools
------------------	---

Aesthetics

Colour	Stainless steel/Black	Digit display color	Multicolor
Door with stainless steel stripes	Yes	Front panel	Glass/Stainless steel
Display type	Yes, 7 inches touch	Logo	Smeg printed

Controls

Recipes number	512 max.	Hold function	Same time
Preset recipes	Yes	Forced cooling	Boiler 71°C/Tank 60°C-50"
Timer setting range	1 minute-12h, 12h-59minutes, endless	Chimney regulation	Scheduled start H/12
Cooking steps	Yes	Wash programs	Yes
Delayed start	Boiler 71°C/Tank 60°C-50"; Same time	Haccp data	Scheduled start H/12
Pre-heating	Boiler 71°C/Tank 60°C-50"	Self diagnostic	Yes

Programs / Functions

Backing functions



Fan forced



Direct steam



Open boiler steam



Core probe + Δ t



Combined cooking



Vacuum low temperature



Grill



Proofing

Adjustable fan speed:



Adjustable fan speed in percentage

Wash system:



Automatic /self-cleaning washing

Options

Solutions K510X

Accessories Included

Probe 4 points external core probe

Electrical Connection

Plug Not present

Construction

Oven materials	Ever Clean enamel	Drain diameter	40mm
Cavity dimensions (lxdxh)	670x560x420mm	Exhaust position	Back
Cavity material	Stainless steel	Components cooling system	Yes
Shelves number	5 GN1/1	Timer type	Electronic timer
Tray frame support	Stainless steel AISI 304	Temperature range	30-270°C
Tray frame support	Chromed wire double format	End cooking signal	Yes
Shelves distance	90 mm	Manual reset safety thermostat	Yes
Door construction	Yes	Removable deflector	Yes
Door opening	Lateral	Detergent type	Liquid
Handle type	New ergonomics	Lighting	1 LED lamp
Openable glass	Openable	Light power	3.6 W
Fan type and number	1 contrarotating fan with time direction reversal	USB port	Si

Pulse fan	2 contrarotating fans with time direction reversal	Components cooling system	Yes
Engine speed	200W	Water load pipe	Yes
Engine speed	Ever Clean enamel	Water entries number	1
Max standard speed motor rpm	2	Water load pipe	Yes
Low speed rpm	1425 rpm	Power cable length	170 cm
Water injection on each fan	Yes	Back panel	Galvanized
Humidification levels	Automatic and progressive percentage	IPX protection	Scheduled departure and end cooking with automatic shutdown
Open boiler	Yes		

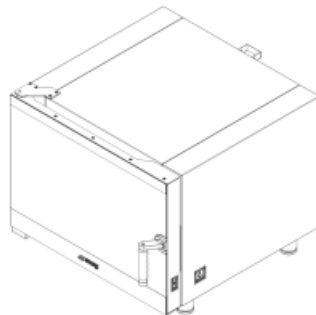
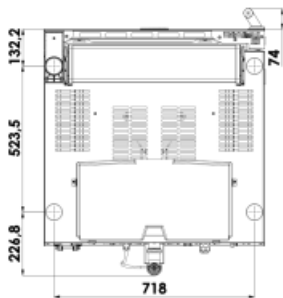
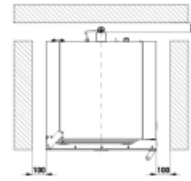
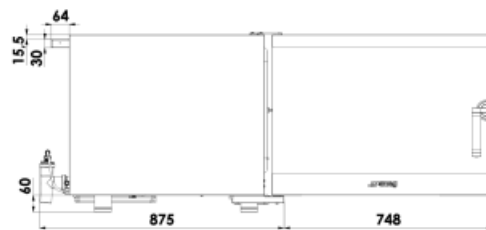
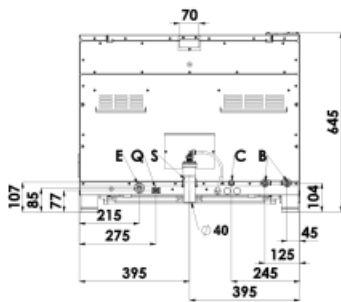

Q	MORSETTO EQUIPOTENZIALE EARTH TERMINAL
E	CAVO ALIMENTAZIONE ELETTRICA ELECTRICITY SUPPLY CABLE
C	TUBO DI CARICO FILLER HOSE
S	TUBO DI SCARICO DRAIN HOSE
B	BYPASS DECALCIFICATORE BYPASS DESCALER

Not included accessories

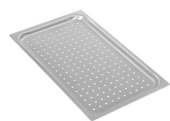

TF11XH2

Perforated aluminium GN1/1 tray for Galileo professional

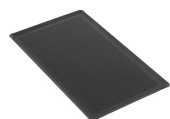

TMF11TH2

GN 1/1 non-sticking microperforated tray



R5GN

GN trays guide kit for Galileo professional



KCAM5

Chimney kit for Galileo professional 4 and 5 trays



T11XH20

2cm height aluminium GN1/1 tray for Galileo professional



T11XH65

6,5cm height aluminium GN1/1 tray for Galileo professional

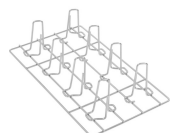

G11X8P

8 vertical GN1/1 chicken grid for Galileo professional



KITSTCK55

Conjunction kit between 2 combined 4 and 5 trays ovens



TB45LSE

Water treatment filter head connection kit



SLFT

Galileo professional table shelf kit



R4EN6040

Support kit for EN 600x400 trays



KITPO45

Connection kit for Galileo professional oven and K4610X hood



STDM

Galileo oven support frame - 4 trays

KITDPEC

Galileo professional external detergent lance kit



T11TH20

2cm height GN1/1 non-stick tray for Galileo professional

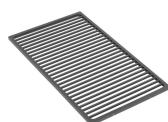

G11T

Non-stick GN1/1 tray for Galileo professional



STDBC

Galileo oven support table

**FB45LSE1100**

Water treatment filter for PO45LSE;
7.900 litres capacity with 10 Kh°
hardness and bypass set 1

**FB45LSE500**

Water treatment filter for Galileo
professional oven; 4.675 litres
capacity with 10 Kh hardness and
bypass set 1











**STDH****T8S11T**

8 holes GN 1/1 non-sticking tray for
Galileo professional

**T11TH40**

4cm height GN1/1 non-stick tray for
Galileo professional

Symbols glossary (TT)

	...		...
	Core probe + Δt		Automatic washing
	Dry heat for a perfect grill		Steam generated by injecting water into the fan and evaporation on the heating element
	Saturated steam created by boiling in the cavity		Steam and hot air combined cooking
	Low cooking sous-vide		Humidity and heat controlled proofing