

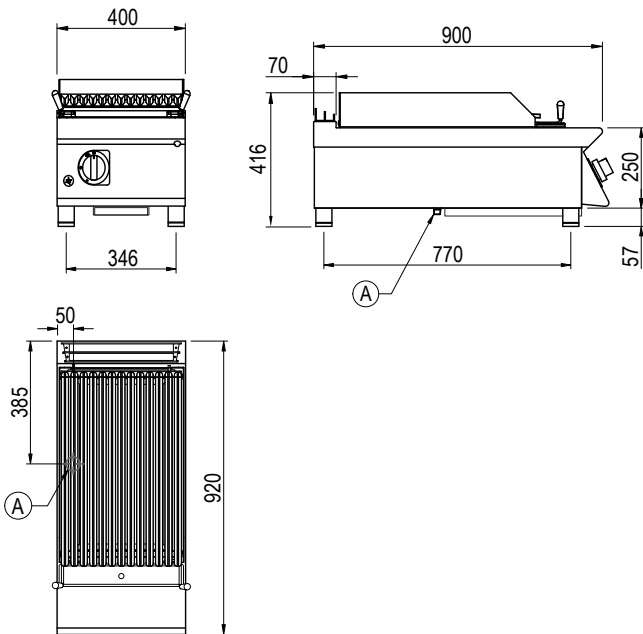

**Product Information:**

- Class leading, European style, professional quality and reliability since 1963
- 900 series, high performance gas char grill (39.6 MJ/h)
- Piezo ignition burners with flame failure device and pilot burner
- Temperature regulation via variable power flame control
- Lava stone rack over burners spreads and radiates heat while vaporising fats for that authentic char grill taste
- Supplied standard with specialised V-shaped meat char plate to capture and drain fat to front drip tray while providing defined char markings
- Supplied with removable internal grease tray, ash drawer and char plate
- Fish char plate sold separately (SPGI.2009849)
- Robust 304 grade stainless steel construction with rounded corners and splashguards
- Open base with optional door available (SPGI.2016437)
- Height adjustable stainless steel feet for a 900mm working height
- 24-month warranty

**General Drawing:**



**Specifications:**

<b>Model</b>	GL920GCT	
<b>W x D x H (mm)</b>	400 x 920 x 416	
<b>Weight</b>	70kg	
<b>Packed Dimensions (mm)</b>	450 x 1030 x 570	
<b>Packed Weight (mm)</b>	77Kg	
<b>Gas Connection</b>	Natural 1/2" BSP	Universal LPG 1/2" BSP
<b>Minimum Normal Test Gas Pressure</b>	1.3 kPa	2.75 kPa
<b>Maximum Normal Test Gas Pressure</b>	3.5 kPa	3.5 kPa
<b>Nominal Test Point Pressure</b>	1.0 kPa	2.65 kPa
<b>Total Nominal Gas Consumption</b>	39.6 MJ/h	39.6 MJ/h

**Note:** It is the responsibility of the installing gas plumber to ensure correct supply and connection sustaining appropriate pressure, when all installed gas appliances are operating at maximum.

**Legend:**

A Gas Connection