

DATE	REV.	REVISION	DRAFTING	CHECKED
2019.06.13	A/0	NEW	DGY	

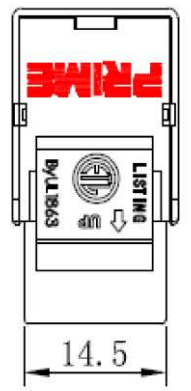

**PIN/PAIR ASSIGNMENTS**

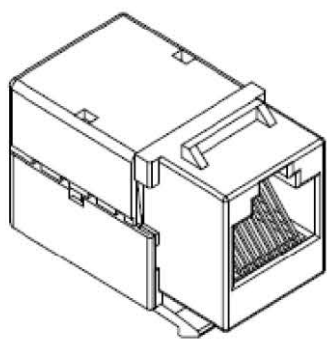
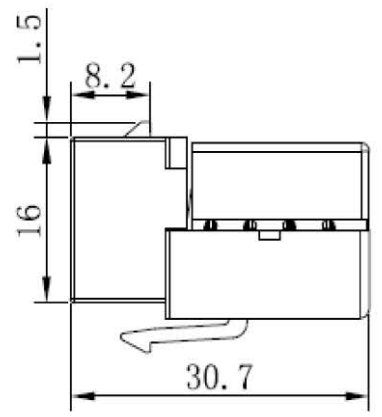
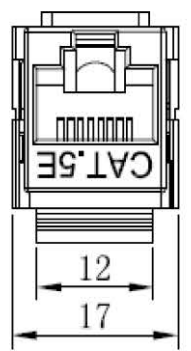
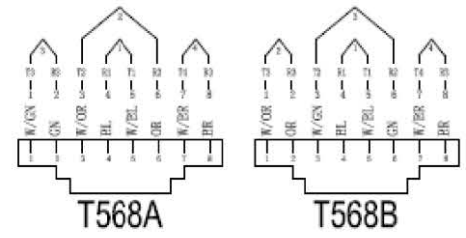

**SPECIFICATION**

- Housing material: Self-extinguished plastic UL 94V-0.  
Insert material: PC UL 94V-0 rated,  
Contact Finished: 50 micro-Inch gold over, Nickel 40 micro-Inch.  
Color: White, Ivory, Blue, Orange, Red, Black.
- IDC Housing: Self-extinguished plastic UL 94V-0, Color: Black.  
IDC Terminal: Phosphor Bronze, nickel plated 50-60 micro-Inch.
- P.C.Board: FR4, 1.6mm.
- Operation Temperature : -10° C to 60° C.
- Insertion Force: 900gms for 8 contacts.
- Retention Strength : 7.7 kgs between jack and plug.
- Durability : 750 Cycles contact resistance test check every 100 Cycles, Insertion cycles at 20 cycles/minute max.
- Certifications: FCC, ANSI/TIA-568, 2-D

**ELECTRICAL**

- Current rating: 1.5 Amps
- Insulation resistance: 500 MΩ
- Contact resistance: 20 mΩ
- DC resistance: 0.1 Ω
- Dielectric withstanding voltage: 500 V



DRAW. NO		TITLE	Cat. 5E Mini 90° Unshielded Keystone Jack 110 type		
CUSTOMER		DRAW	DGY	DATE	2019.06.13
CUSTOMER P/N		CHECK	DATE	2019.06.13	
UNIT	mm	APPROVED	SHEET	1 OF 1	

KJ11016032	Blue	Unless specified on the drawing, tolerances are per the follows: X. ±0.30 X° ±3 .X ±0.20 .X° ±0.3 .XX ±0.10
KJ11016038	White	
KJ11016030	Ivory	
KJ11016035	Orange	
KJ11016036	Red	
KJ11016031	Black	
Part Number	Color	

Material	Part Number	Note	<input checked="" type="checkbox"/> RoHS	<input type="checkbox"/> Reach	<input type="checkbox"/> GP	<input type="checkbox"/> HF	<input type="checkbox"/> Other	RD		
----------	-------------	------	--	--------------------------------	-----------------------------	-----------------------------	--------------------------------	----	--	--