

# PMX

## POWER ASCENDER

User manual

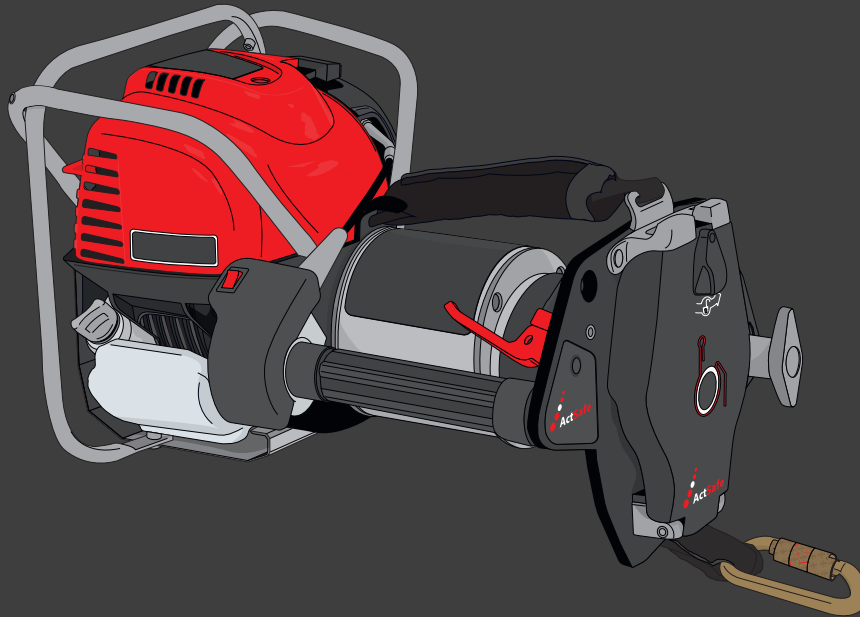

Introduction	A
Product safety & system description	B
Rope	C
General safety guidelines and lifting systems	D
Starting/operating the Engine	E
How to use the Ascender	F
Service & maintenance	G
Warranty terms	H
Technical data	I





**HAND-BUILT  
IN SWEDEN**

## DISCLAIMER

### WARNING

**Training and experience are required to lower the risk of serious bodily injury or death.**

This user's manual provides general information about safe operation and risks associated with the use of the ActSafe PMX Power Ascender. It also gives details of maintenance procedures.

Never use the equipment unless you have read and understood this manual and completed ActSafe approved training in the use of the Power Ascender System. ActSafe Systems AB, our partners and subsidiaries, disclaim any liability for damages, injuries or death resulting from the use of the equipment which is not in compliance with this manual.

This manual may be updated without notice.

For more information about updates and safety warnings, visit [www.actsafe.se](http://www.actsafe.se)



**Failure to read and follow the instructions within this manual may result in fire, damage to property, personal injury or death.**

## FOREWORD

Thank you for choosing the ActSafe PMX Ascender from ActSafe Systems.

This Ascender has been designed as an ultra-portable and versatile lifting tool for lifting people or equipment in a safe and effective way. It revolutionises working in a vertical environment.

# A

## INTRODUCTION

About ActSafe	<b>A.01</b>
About this manual	<b>A.02</b>
Definitions	<b>A.03</b>

# A

**We are completely committed to our customers and do our utmost to deliver top quality products and service.**



## **A.01** ABOUT ACTSAFE

ActSafe is a pioneer in developing powered rope ascenders and has been delivering high-performance equipment since 1997.

ActSafe has a worldwide distribution network of dedicated experts selling our innovative products to a wide variety of users. Our Power Ascenders have been successfully used for installing fireworks at the top of the Eiffel Tower, hostage rescue from pirates at sea and providing essential logistical support in offshore wind turbines.

ActSafe products are redefining the possibilities for work in vertical environments.

## A.02 ABOUT THIS MANUAL

This manual gives detailed information on features and safety. However, this manual cannot replace the need for training and experience. The Ascender must only be used by operators who have undergone the ActSafe-approved training.

Safety messages of extra importance are highlighted throughout this manual using the signals 'danger', 'caution', 'recommendation' and 'note':



### **DANGER**

Not following instructions or training methods may result in **SERIOUS BODILY INJURY** or **DEATH**.



### **CAUTION**

Not following instructions or training methods may result in **BODILY INJURY**, or **DAMAGE TO PROPERTY**.



### **RECOMMENDATION**

Instructions and tips on how best to use the Ascender.



### **Note**

Important information on the use of the equipment used with the Ascender.

## A.03 DEFINITIONS

### **Active/loaded rope**

Loaded end of the work-positioning rope system.

### **Anchor**

Attachment point for rope or Ascender.

### **Ascending**

Moving up the rope.

### **Backup system**

A rope system which captures the load in case of primary rope failure. Approved according to backup system requirements.

### **Competent Person**

Operator with adequate training, experience and certification.

### **Descending**

Moving down the rope.

### **Passive/dead rope**

Unloaded end of the work-positioning rope system.

### **Primary rope**

Work rope system used with Ascender. Rope must be 11 mm and approved according to *EN1891 A* or be an ActSafe Equipment Lifting Rope depending on the application.

### **User/operator**

Operator of the Ascender.

### **Safety Factor**

The Safety Factor of equipment is the ratio between the breaking strength and the Safe Working Load (SWL).

### **Secondary rope**

See 'Backup system'.

### **SWL**

Safe Working Load. The maximum load (as certified by a competent person) that an item of lifting equipment may raise, lower or suspend under particular service conditions.

### **WLL**

Working Load Limit. The maximum load that an item of lifting equipment is designed to raise, lower or suspend.



# B

## PRODUCT SAFETY & SYSTEM DESCRIPTION

Product safety	<b>B.01</b>
Usage exclusions	<b>B.02</b>
System description	<b>B.03</b>
Rope mechanism	<b>B.04</b>

# B

## B.01 PRODUCT SAFETY



ActSafe Ascender operators must, before first use, have undergone training in the safe use of the Ascender by either ActSafe Systems AB or by an ActSafe-approved training partner or ActSafe distributor.

The ActSafe Ascender must be checked before and after every use by a Competent Person and must undergo a minimum of one inspection per year by ActSafe Systems AB or an ActSafe-authorized person. More frequent inspections may be required by your national regulations.

## B.02 THE ASCENDER **MUST NOT BE USED:**



- » For any purpose other than that for which it has been designed
- » In an explosive environment
- » If modified in any way by anyone other than ActSafe Systems
- » After a free fall from a height of more than 0.5 m or against any hard surface
- » The Ascender system should not be exposed to high impact forces caused by people or loads falling into the system
- » If subjected to misuse in any way so that parts or components could have been damaged
- » If the operator is unsure of how to use the Ascender safely

# B

## B.03 SYSTEM DESCRIPTION

### CAUTION

Do NOT use the carrying handle or the engine protection frame as rigging points, this part is only designed to lift the weight of the PMX Ascender!

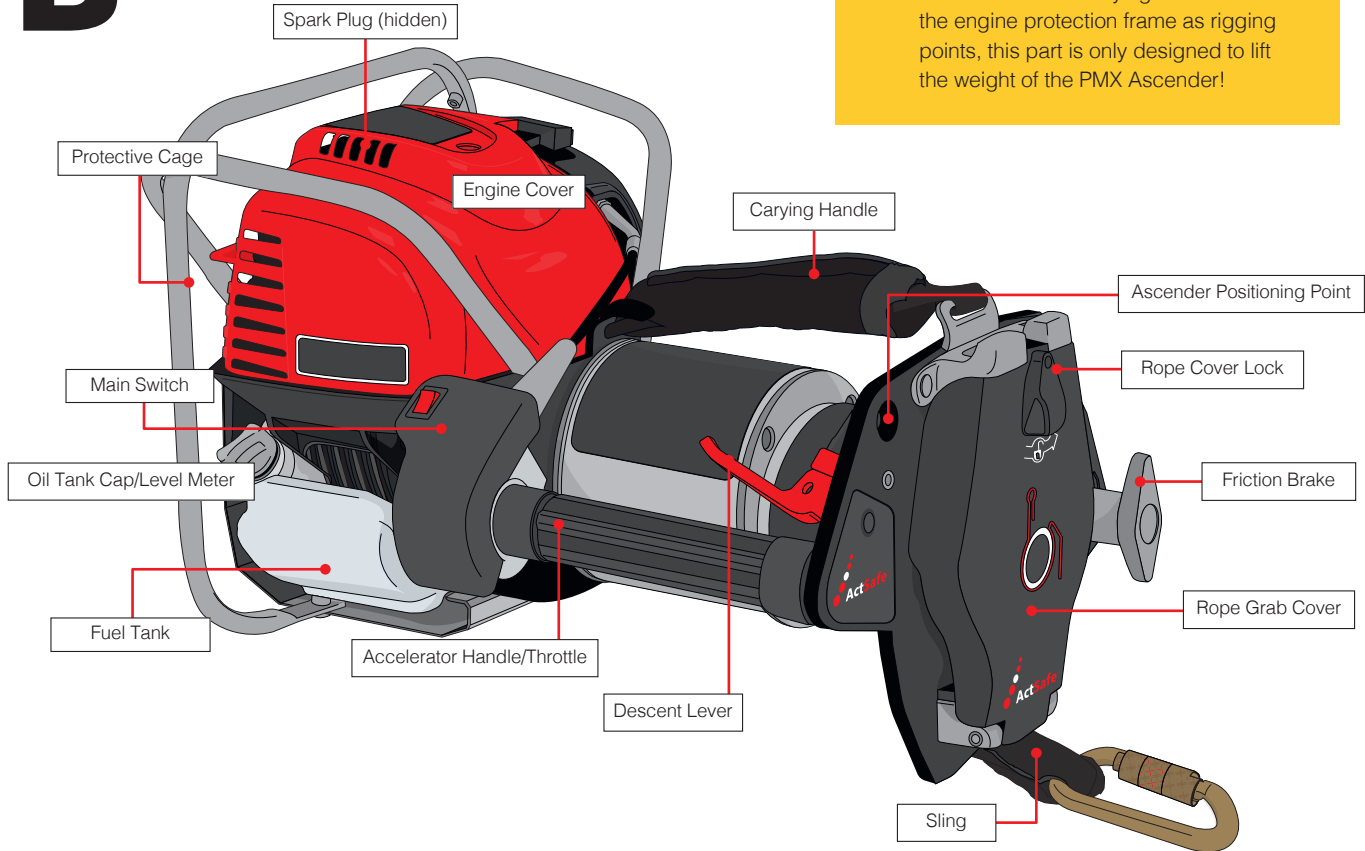

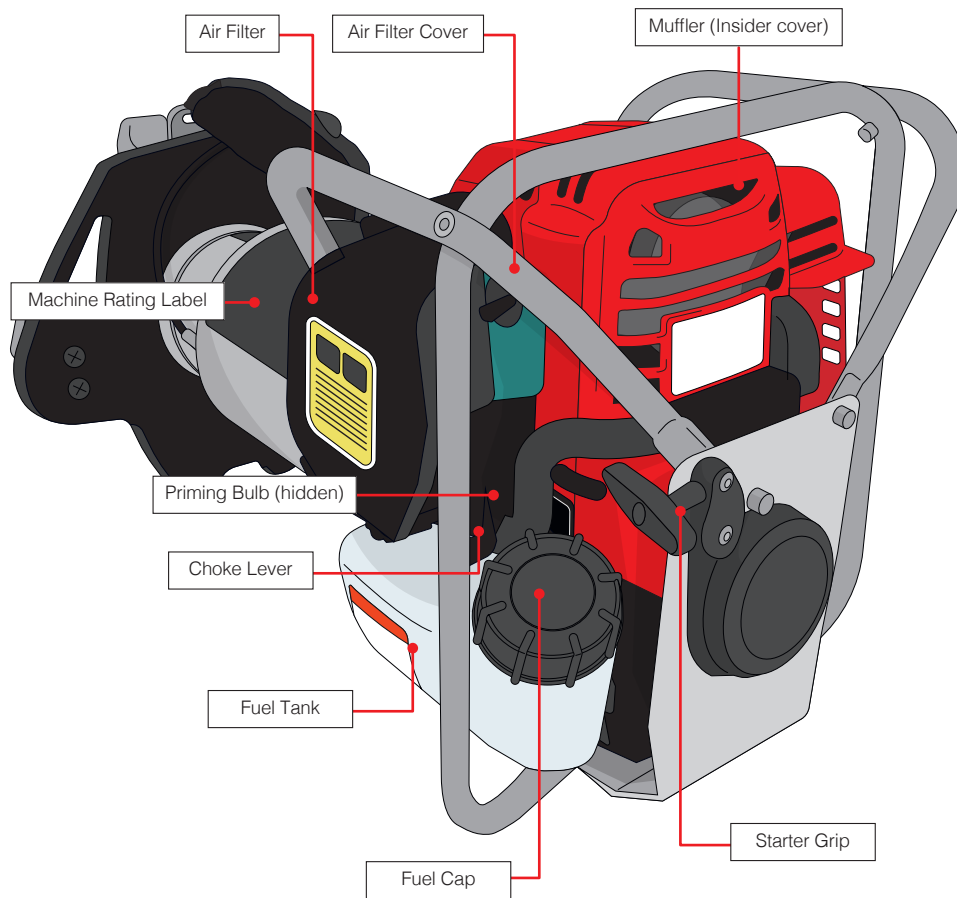

### Machine Rating label

The Ascender is supplied with a machine rating label attached to the housing. This label must not be removed!

The PMX Ascender is approved under the Machinery Directive 2006/42/EC and is designed for lifting both people and equipment with a safe working load of 250 kg.

## B.04 ROPE MECHANISM

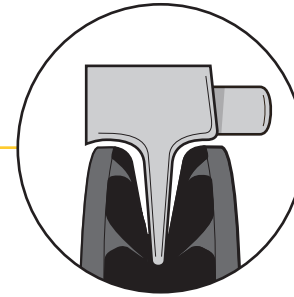
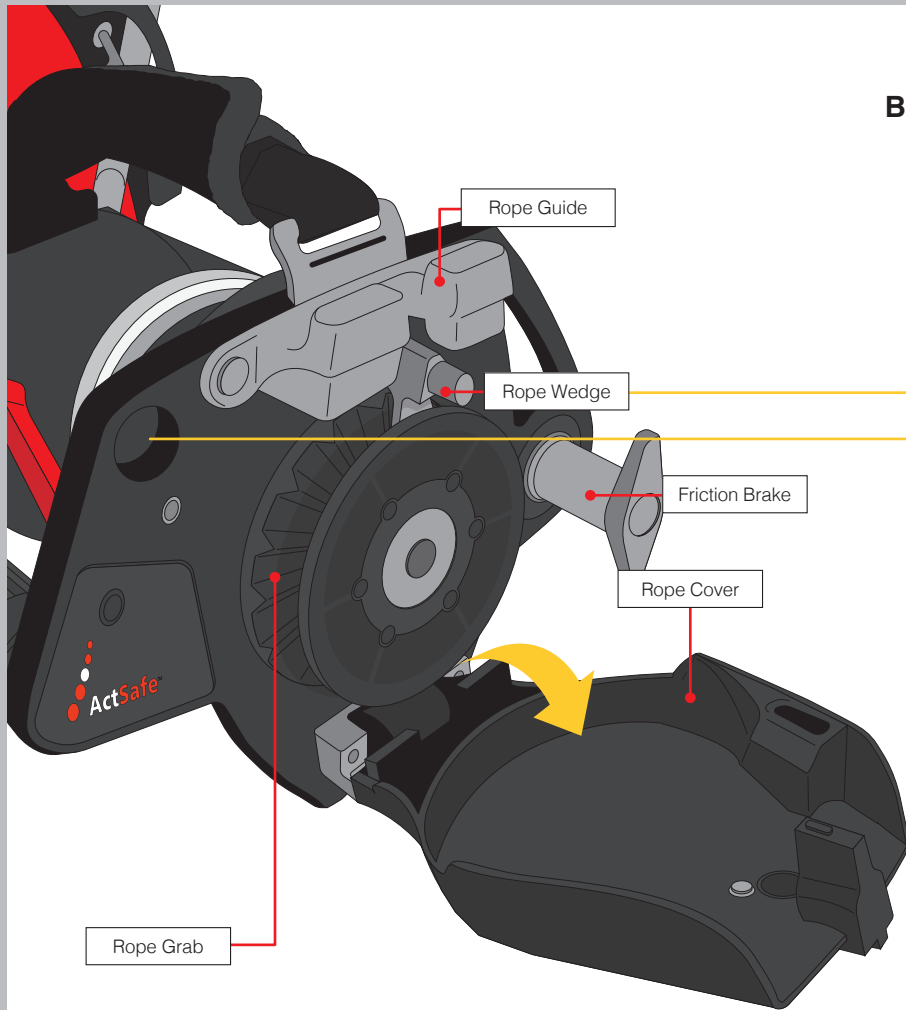

The Ascender Positioning Point should preferably be used for positioning the Ascender but in some cases can be used for rigging setups (expert use only).

# C

## ROPE

Rope type  
and preparation

---

**C.01**

# C

## C.01 ROPE TYPE AND PREPARATION

**The correct choice of rope type depends on whether the Ascender is being used to lift or lower equipment or personnel.**

**Check with your ActSafe supplier to determine which rope is the most suitable to use.**

### **Rope recommendations**

Rope recommendations for the PMX Ascender depend on the type of application, whether personnel or equipment lifting.

### **Equipment lifting**

The ActSafe Equipment Lifting Rope (ELR) is the only approved rope to be used in the equipment lifting system and can be ordered at ActSafe or via your ActSafe distributor.

### **Personnel lifting**

*EN1891 A* 11 mm low stretch kernmantle rope of a solid construction. Soft ropes have the tendency to deform under load and should be avoided because of poor grip and the risk of getting jammed in the rope grab system.

Ask your local ActSafe distributor for rope recommendations and also perform a suitability test before first use. Load the intended rope in the Ascender and lift 200 kg. There should be no slipping of the rope.

### **Pre-Soaking**

It is recommended that only pre-soaked ropes are used with ActSafe Ascenders. New ropes should be put in cold water (<40°C) for 24 hours and dried slowly afterwards.

This will make ropes more suitable for use in ActSafe Ascenders for two reasons:

#### **1. Rope density**

Pre-soaking makes ropes denser. The fibres will absorb the water and will shrink when drying.



The result is that all fibres become more densely aligned and the sheath sits tighter around the core of the rope. This will make the rope more solid and will consequently result in less mantle slippage and deformation and thereby lead to better grip in the Ascender.

## 2. Oil dissolution

During the production process some oil is added to the rope fibres in order to reduce the friction between the individual fibres. When soaking the rope in cold water some surface oil in the sheath of the rope will dissolve. This will contribute further to a better grip. Do not soak ropes in warm water, this will lead to greater dissolution of oil, which will have a negative impact on the rope properties.



### CAUTION

Always make sure that the rope is in good condition.



### RECOMMENDATION

A new rope will get an increased service life if it is soaked in cold water before the first use.

Avoid getting sand or dirt onto/into the ropes since it will wear the rope grab and rope guide. Use a rope mat, rope bag or similar.



# D

## GENERAL SAFETY GUIDELINES AND LIFTING SYSTEMS

General safety guidelines	<b>D.01</b>
Personnel lifting	<b>D.02</b>
Personnel safety checklist	<b>D.03</b>
Personnel lifting setup	<b>D.04</b>
Equipment, materials and tool lifting	<b>D.05</b>
Basic lifting safety rules	<b>D.06</b>
Equipment lifting setup	<b>D.07</b>
ActSafe Training Network	<b>D.08</b>

# D

## D.01 GENERAL SAFETY GUIDELINES

**The PMX Ascender is designed for both personnel and equipment lifting. These applications have different system requirements that are described in the following pages.**



### **DANGER**

DO NOT USE the Ascender if you are tired, ill, using prescription medication that prevents you from using machinery, or under the influence of alcohol or drugs.

- » Operate the Ascender according to the advice contained within this user manual and pre-planned work instructions (lift plan, access plan)
- » Only trained and competent operators should operate the PMX Ascender and its ancillary equipment
- » Plan and evaluate your work carefully. A rescue plan should be in place
- » Plan for appropriate supervision of work
- » Perform a toolbox talk/safety briefing before starting the work
- » Use only approved and inspected equipment. This goes for the Ascender, PPE and/or lifting equipment
- » Inspection of equipment must be carried out in accordance with local regulations. The Ascender should undergo a documented inspection at least once every year
- » Pre-use check of the Ascender should be carried out in accordance with the inspection guidance provided
- » Use PPE (Personnel Protective Equipment) such as helmet, gloves and protective eye wear when required
- » Keep your hands, hair and clothing away from moving parts
- » Do not hold the loaded rope when ascending as there is a risk of pinching
- » Keep a constant eye on the rope guide to ensure that the rope is running smoothly through the rope mechanism

## D.02 PERSONNEL LIFTING

The PMX Ascender, when used to lift people, must be used with personnel protective equipment approved for work at height, rope access and/or rope rescue.

### Basic requirements:

The rope system must consist of a primary work rope system and a secondary backup rope system.

For personnel lifting the primary rope used in the Ascender must be approved to *EN1891 A* and have a diameter of 11 mm and the backup system must fulfill the respective requirements.

Each rope system must be connected to at least one anchor that can hold a minimum of 15 kN or must fulfil appropriate anchor requirements.

A competent person shall judge if the anchor points are sufficient and safe to use.

### DANGER

DO NOT USE the Ascender without a backup system.

## D.03 PERSONNEL SAFETY CHECKLIST

### Before use make sure that you:

- ✓ Check all equipment and components
- ✓ Wear appropriate clothing and tie back any loose clothing or hair
- ✓ Do not swing excessively while descending/ascending
- ✓ Only use the Ascender if you have successfully completed approved ActSafe training
- ✓ Have an emergency plan in place

### CAUTION

Always hold the unloaded rope when using a passive setup

### RECOMMENDATION

The supplied ActSafe karabiner may be replaced with any other *EN362* connector. All other parts of the Ascender should only be replaced with original ActSafe parts by an ActSafe-approved service engineer.

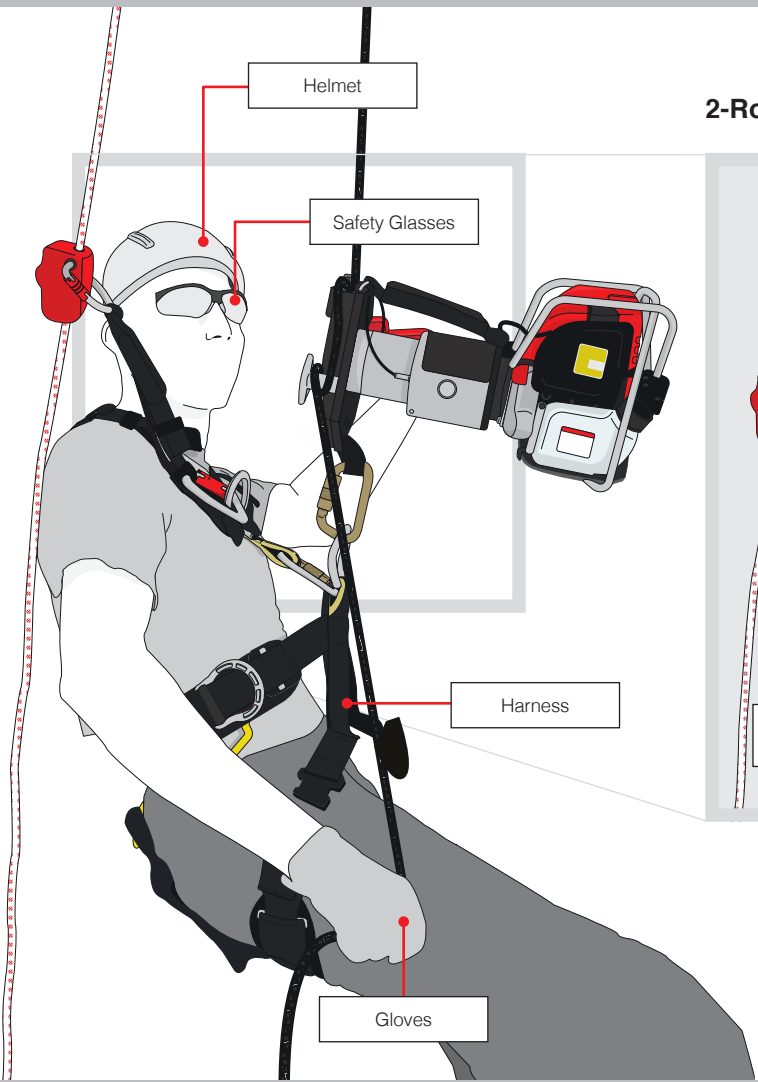

## 2-Rope system

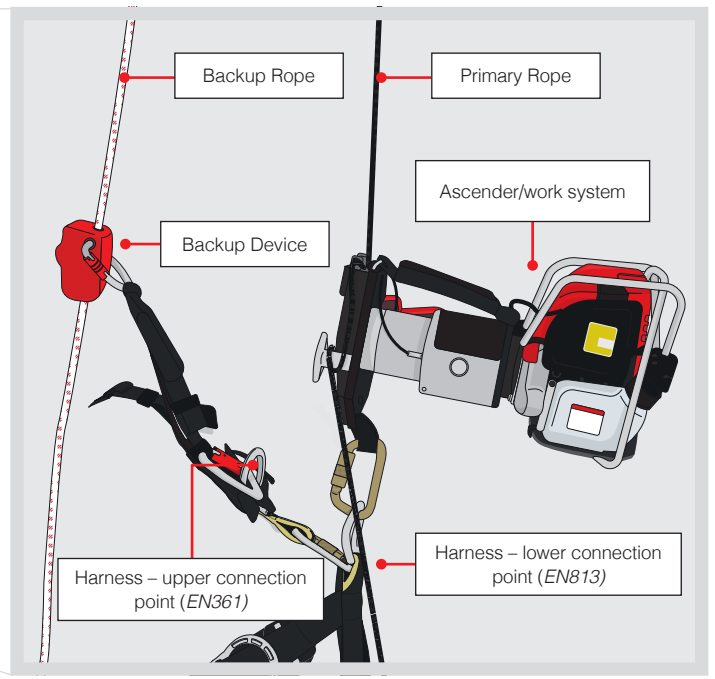

## D.04 PERSONNEL LIFTING SETUP

Displayed here are the four standard personnel lifting setups that are suitable for use with the PMX Ascender. They are shown for illustration purposes only. For further guidance, please contact ActSafe or an ActSafe distributor.

### Active Basic setup

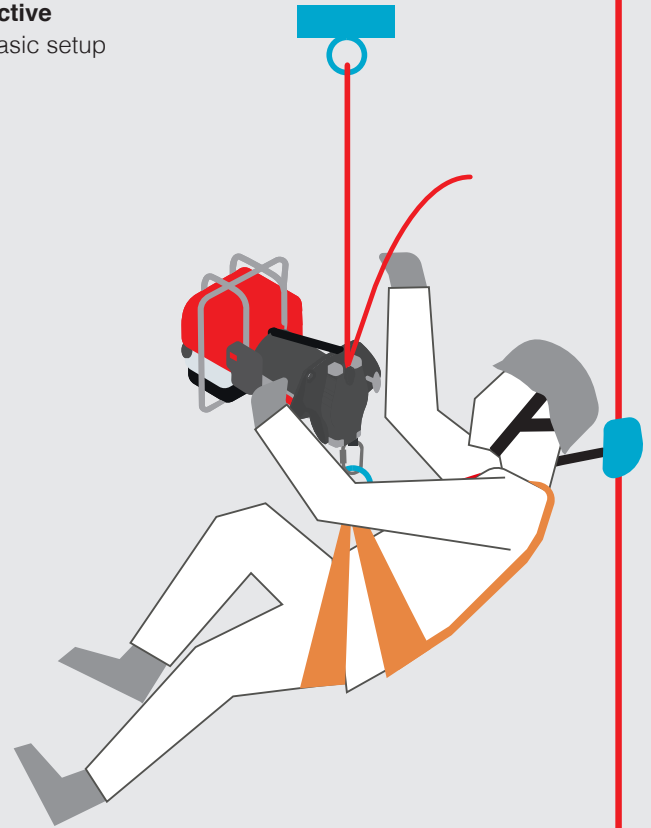

**Passive**  
Basic setup

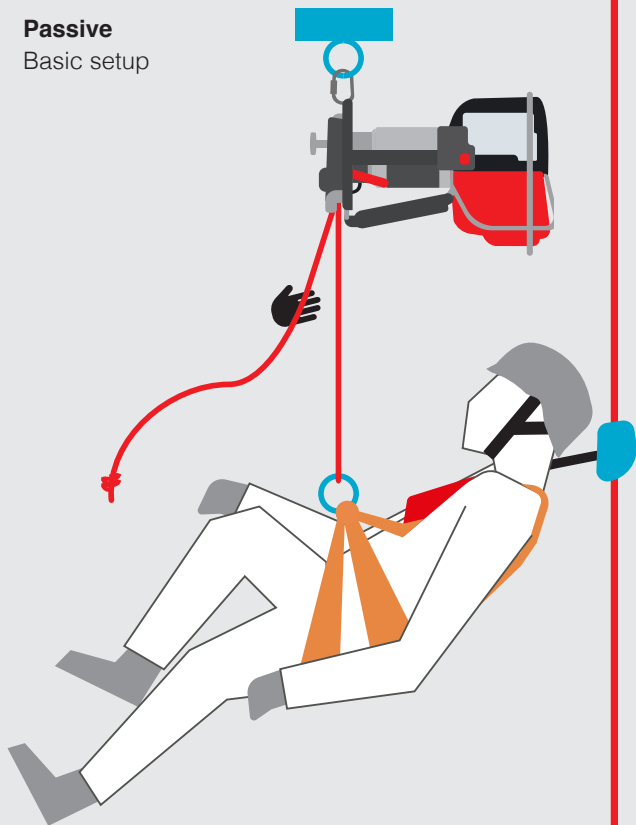

**Deviated**  
Basic Setup

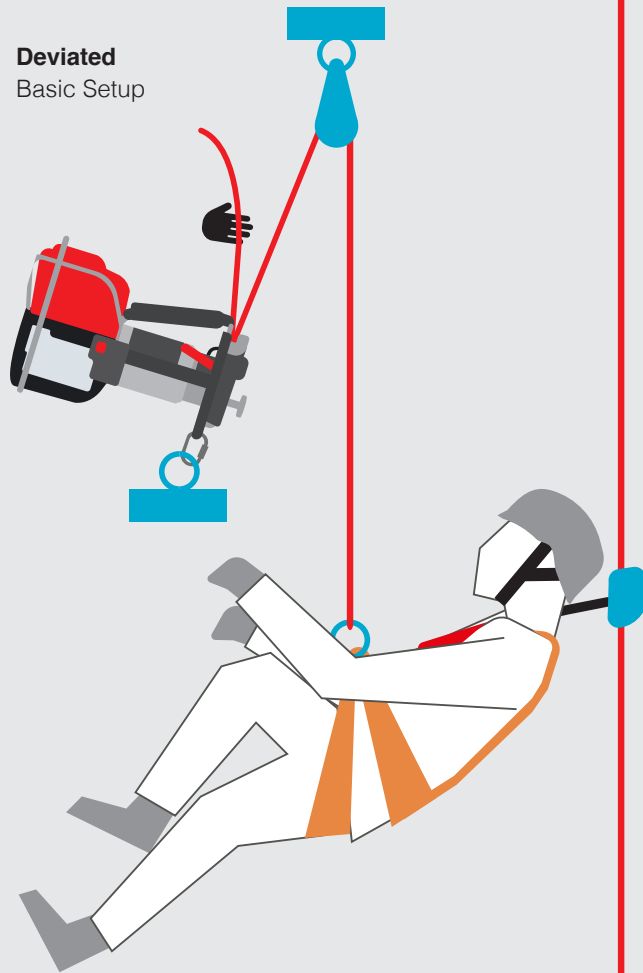



**Pulley**  
Expert use only

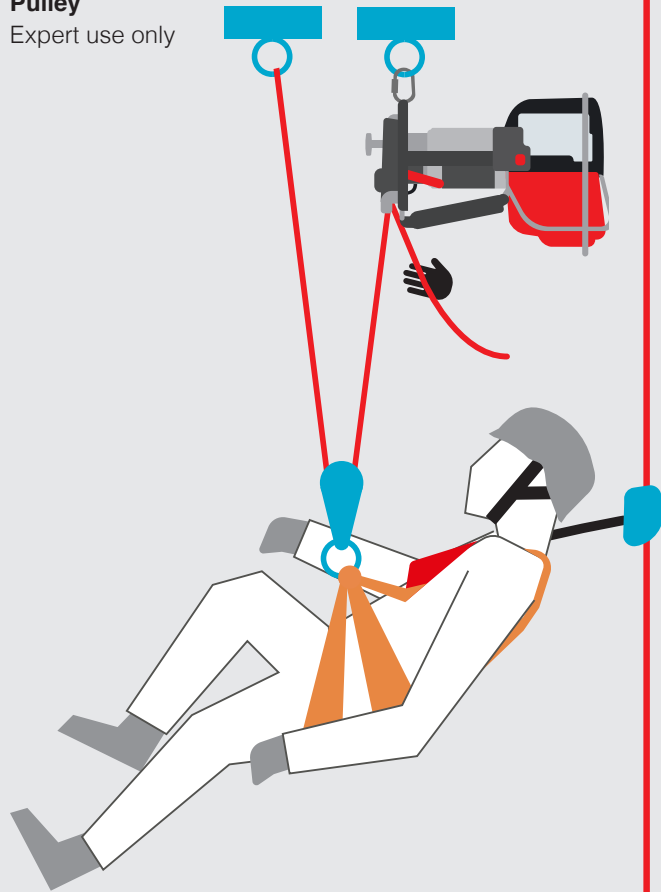

**i** **RECOMMENDATION**

A work seat is recommended for comfort and safety.

**✓** **Note**

When driving the Ascender the operator must wear a fall arrest harness that is also suitable for work-positioning/rope access.

## D.05 EQUIPMENT, MATERIAL AND TOOL LIFTING

The PMX Ascender is, in combination with the ActSafe Equipment Lifting Rope (ELR), approved under the Machinery Directive as an equipment lifting system provided that all other equipment used also meets lifting requirements.

### **i** RECOMMENDATION

Lifting operations are ideally performed with a three person team. A lifting supervisor, a slinger for attaching loads and an ascender operator.

### **✓** Note

The supplied ActSafe karabiner may be replaced with any *EN13889* shackle with a minimum WLL of 0.5 t. All other parts of the Ascender should only be replaced with original ActSafe parts by an ActSafe-approved service engineer.



## D.06 BASIC LIFTING SAFETY RULES



Always keep an eye on the load while lifting



Avoid excessive inching (i.e. short pulses of the motor)



Do not exceed the Safe Working Load (SWL) of the entire lifting system



Stay clear of the load whilst lifting



Do not try to lift fixed or obstructed loads



Do not stand under the suspended load



Do not side-pull loads



Use hand signal or radio communications during lifting operation

## D.07 EQUIPMENT LIFTING SETUP

Displayed here are the four standard lifting setups that are suitable for use with the PMX Ascender. They are shown for illustration purposes only. For further guidance, please contact ActSafe or an ActSafe distributor.

### ! CAUTION

DO NOT let the rope become obstructed or blocked when being guided into the Ascender

Avoid excessive loading angles

### ✓ Note

The Ascender operator should, at all times, control the unloaded rope during lifting operations to avoid the rope twisting when going into the Ascender.

**Passive**  
Basic setup



**Deviated**  
Basic setup

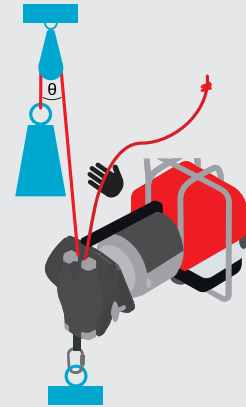

**Active**  
Expert use only

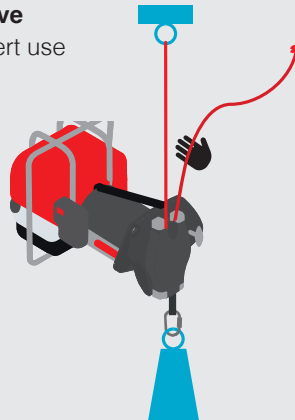

**Pulley**  
Expert use only

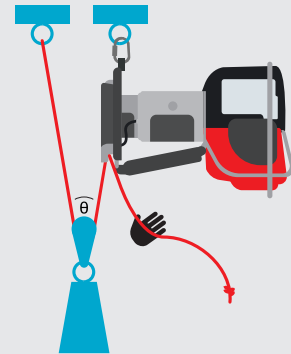

## D.08 ACTSAFE TRAINING NETWORK

The ActSafe Power Ascenders are extremely versatile high-tech lifting tools that are designed for use in demanding environments.

Working with these Ascenders requires experience, competence and a thorough understanding of their possibilities and limitations. Therefore, training is essential.

We offer the ActSafe training programme through our network of highly competent instructors, who are specialists in their respective field of operation and will help you get the most out of your ActSafe Ascender.

ActSafe training is available for different skill levels and fields of application and can be provided on site or in training centres all around the world. Get in touch with your local distributor or with ActSafe to learn more about our training programmes.



## Operator lifting

### **ACTSAFE BASIC ASCENDER TRAINING**

**Experience:** Working at height training required.

**DURATION:** 1 DAY

This training is designed for operatives who need good basic understanding for a specific application of the Ascender.

### **ACTSAFE ADVANCED ASCENDER ACCESS TRAINING**

**Experience:** For rope access professionals.

**DURATION:** 2 DAYS

This training is designed for rope access operatives to provide an advanced understanding on how to use the Ascender in a rope access environment.

### **ACTSAFE ADVANCED ASCENDER RESCUE TRAINING**

**Experience:** For rope rescue professionals.

**DURATION:** 2 DAYS

This training is designed for rope rescue professionals to learn about rescue capabilities of the Ascender.

## Equipment lifting

### **ACTSAFE EQUIPMENT LIFTING OPERATOR TRAINING**

**Experience:** Delegate must have completed training for personnel safety.

**DURATION:** 4 HOURS

This training is intended for specialist workers who will use the Ascender as their everyday equipment-lifting tool.

# E

## STARTING/OPERATING THE ENGINE

Engine safety	<b>E.01</b>
Fuel safety	<b>E.02</b>
Starting the engine	<b>E.03</b>

## E.01 ENGINE SAFETY



### **DO NOT START THE ENGINE:**

- » If the Air Filter or its cover has been removed

### **DO NOT RUN THE ENGINE:**

- » Indoors in an unventilated area (exhaust gases contain carbon monoxide, an odourless deadly toxin)
- » Without Silencer. Check the Silencer on a regular basis and replace if necessary

- » If there is an accumulation of grass, leaves or other flammable material under, on or behind the Silencer
- » Open the Fuel Tank or fill the Fuel Tank when the Engine is still hot or running. (the Engine should cool for a least 2 minutes before refuelling)
- » Transport the Engine if there is fuel in the tank
- » Use a removed spark plug to determine whether it is sparking
- » Touch the Silencer, Cylinder or Radiator when they are hot – danger of burn



### **CAUTION**

Make sure that hot engine parts do not come into contact with skin, clothes, rope or anything that would be damaged by excessive heat.



## E.02 FUEL SAFETY



### DO NOT:

- » Run the Engine if petrol has been spilled or it smells of petrol or if there is any other danger of explosion
- » Refuel the Ascender in non-ventilated areas such as inside a building
- » Store, spill or handle petrol near any ignition source, such as unshielded flames, sparks or very hot parts
- » Open the Fuel Cap with the Engine running

### REFUELLING

Follow these instructions when refuelling to minimise risk of fire and personal injury:

- » Turn the Engine Switch off
- » Allow the Engine to cool
- » Open the Fuel Tank
- » Refill the fuel
- » Close the Fuel Tank

Move at least 3 m away from the refuelling site before starting the Engine.

## E.03 STARTING THE ENGINE



### Note

Before starting, ensure that the Engine is filled up with fuel and oil. See section G.01

1. Place the Ascender on the ground.
2. Turn the Main Switch on.
3. Press the Priming Bulb several times until fuel can be seen (A, right).
4. Use the Choke if needed (cold engine) (B, right).
5. Pull the Starter Grip (C/D, over).



### CAUTION

Do not hold the rope just above the winch, there is risk of being pinched.

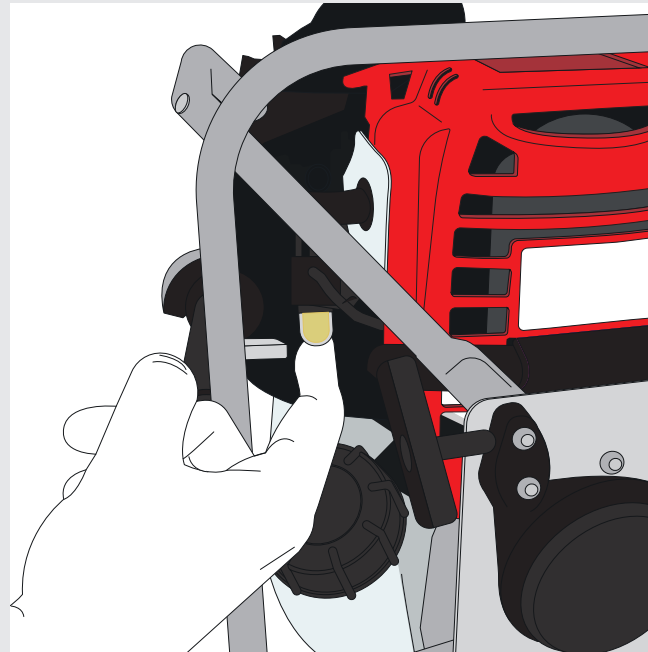

A. Pressing the Priming Bulb

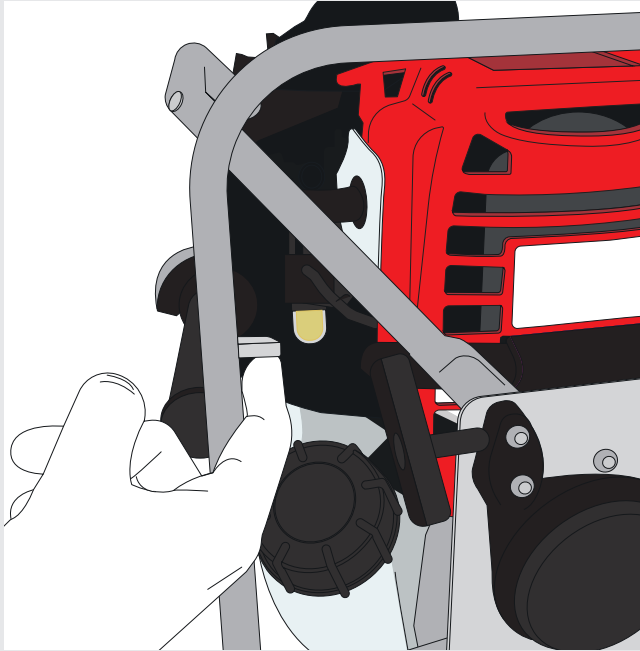

**B.** Activating the Choke

**i** **RECOMMENDATION**

Turn the Choke off as soon as the Engine starts to ignite.

Slowly pull the Starter Grip until you feel resistance. Then pull the Starter Grip strongly in order to avoid backstroke and injuries to hand or arm.

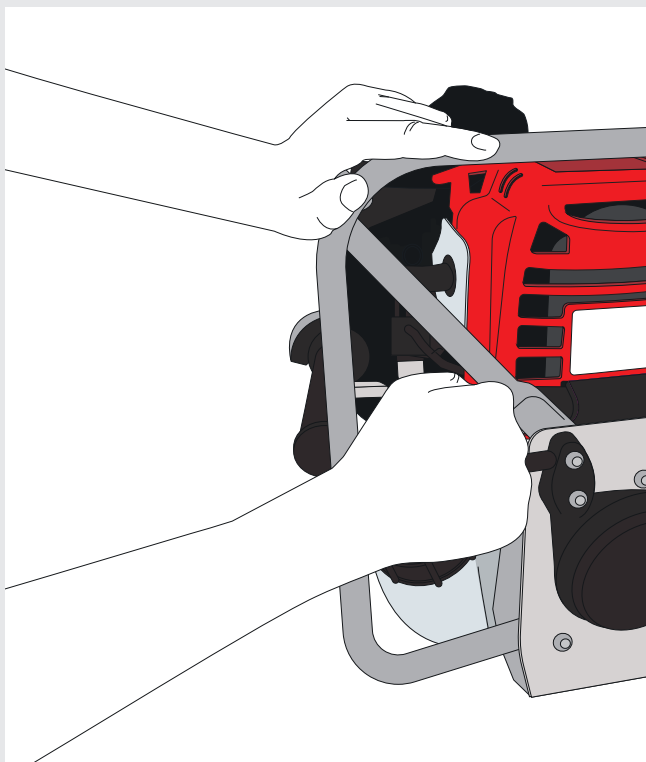

**C.** Hold the Starter Grip firmly

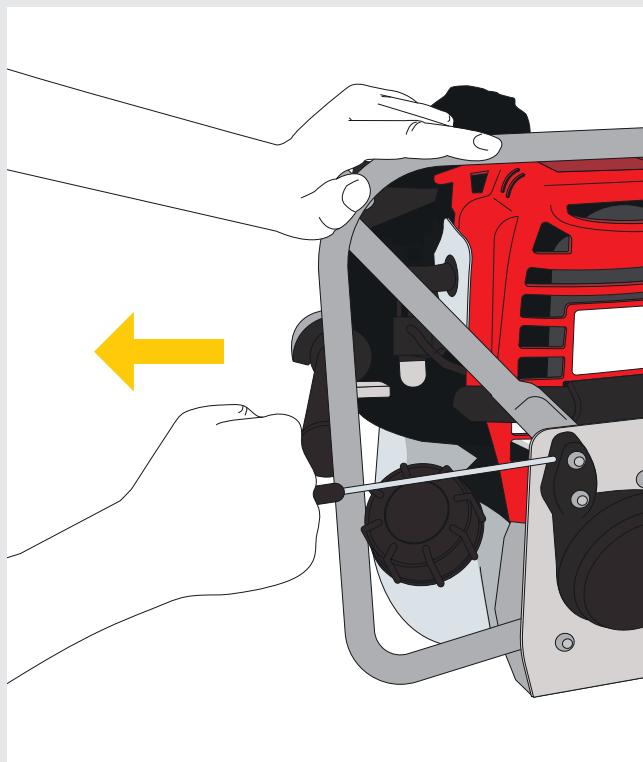

**D.** Pull the Starter Grip

# F

## HOW TO USE THE ASCENDER

Connecting the rope	<b>F.01</b>
Load limitation	<b>F.02</b>
Ascent	<b>F.03</b>
Descent	<b>F.04</b>
Controlled descending with heavy loads	<b>F.05</b>
Twisted rope and rotation	<b>F.06</b>
Checklist before and after use	<b>F.07</b>
Transportation	<b>F.08</b>
Storage	<b>F.09</b>

## F.01 CONNECTING THE ROPE

**The Ascender must be switched off while loading the rope.**

Ensure that the Ascender is switched off.



**1.** Open the Rope Cover by pulling on the Rope Cover and pushing the Rope Cover Lock to the right.

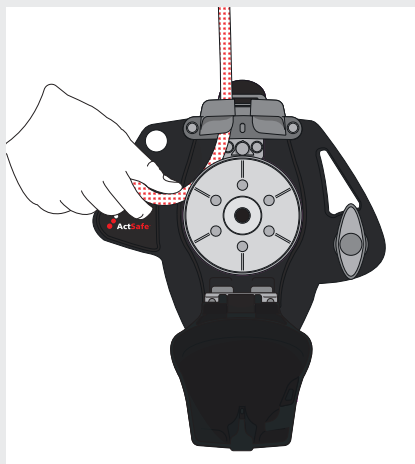

**2.** Feed the rope counter-clockwise through the slot in the Rope Guide and around the Rope Grab.

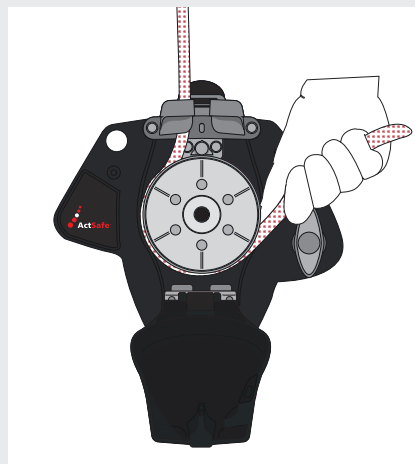

**3.** Continue feeding the rope in a counter-clockwise direction.

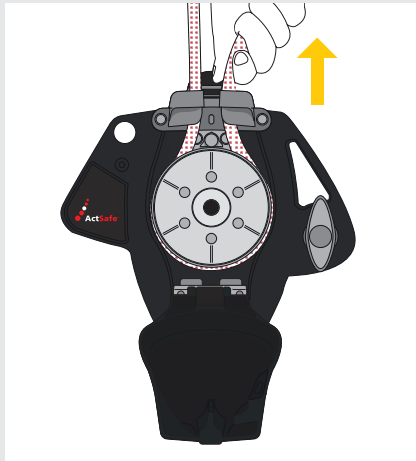

4. Feed the rope again through the slot in the Rope Guide.

Tighten the rope a little. The rope will be pulled into the Rope Grab and the rope cover can be locked more easily.

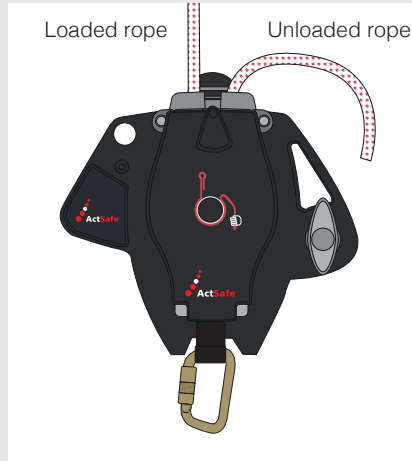

5. Close the Rope Cover and ensure it is locked. The Rope Cover lock should click into its position. A distinct 'click' should be heard. Never attempt to force the Rope Cover.

### **DANGER**

Always check that the rope is attached correctly and has a stop-knot on the other end of the rope. Failure to attach the rope correctly could result in **SERIOUS INJURY OR DEATH.**

### **CAUTION**

Ensure that the Rope Cover is locked into position and that the rope is running the correct way.

## F.02 LOAD LIMITATION

The Ascender is equipped with load limitation that is based on a centrifugal friction function.

When the engine speed increases, two brake shoes are forced towards a drum; the friction causes the rope grab to be driven. If the Ascender is run according to the instructions, the overload protection will withstand 250 kg.

The maximum load can also be limited if the Engine's power diminishes, e.g. if lower quality fuel is used, if the Air Filter is dirty, if the weather conditions are bad, if used at higher altitude etc.

When the Ascender is new, a somewhat lower lift capacity may be experienced due to the fact that the Clutch has not yet been run in.

If the Ascender still has a low lift capacity, despite a running in period, this can be due to worn-out clutch. Contact your ActSafe local distributor.



## F.03 ASCENT

1. Start the engine (see E.03)
2. Turn the Accelerator Handle towards you to increase the speed.
3. Position the Ascender so that the exhaust fumes will blow away from the user.
4. Feed away the 'dead rope' during the first few metres of ascent. After approximately 5 m, the weight of the rope will be sufficient to 'clean' the Ascender from itself.
5. Stop the motion by turning the handle away from you or let it go, then slide the Ignition Switch to the STOP position.



### **i** RECOMMENDATION

Hold on to the primary connection sling or karabiner with your right hand, if balance is needed.

Always keep the backup device in a high position.

Stand straight beneath the anchor point in order to avoid a pendulum movement when starting off the ground.

## F.04 DESCENT

Descending with the ActSafe PMX Ascender is very easy; the rope setup stays unchanged. The primary rope stays connected to the Ascender.

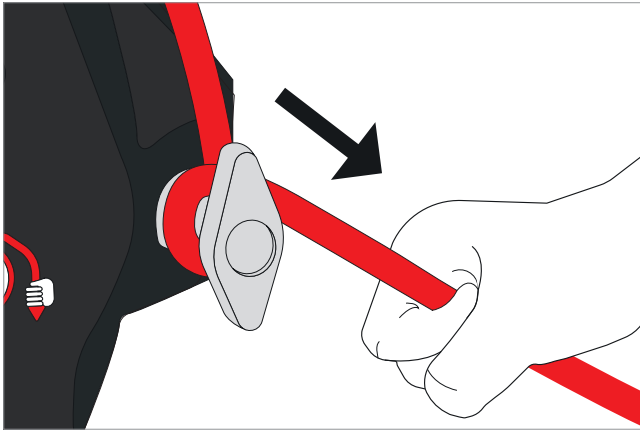

1. Take the primary rope and turn it at least once, in clockwise direction, around the Friction Brake of the Ascender.

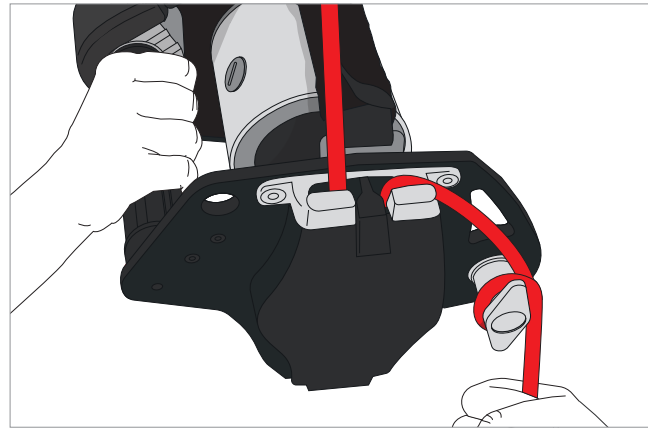

2. Firmly hold the primary rope below the Friction Brake. Place your left hand on the red braking lever just above the Throttle.

3. Pull in the Braking Lever and slowly feed some rope with your right hand and you will descend. The descending speed is controlled by the amount of rope which is fed through the right hand, braking hand; the descending lever always stays completely open. Make sure to keep the braking rope always in your hand and keep your hands away from the Friction Brake while descending!
4. If the braking is not sufficient because of new rope, etc. Stop descending, lock off the backup device, and put the rope a second time around the friction brake to increase the braking power. Start again descending as described at point 3. For descending with loads >150 kg see F.06

5. Stop descending by holding the rope more firmly and releasing the braking lever.

The descending speed is controlled by the braking hand.

ActSafe strongly recommends that the descending speed is NOT controlled by the braking lever; this will wear the engine brake down more quickly.



## CAUTION

Make sure to keep the braking rope always in your hand!

Keep your hands away from the Friction Brake. Ensure that hair, clothing or any loose items are not allowed to become caught.

A stopper knot should always be put at the end of both primary and secondary rope.



## RECOMMENDATION

Adjust the descending speed to the circumstances like: Terrain, load, weather and experience. Be aware and use common sense.

Lock the backup device in a high position when working.

Turn the engine off during descending to avoid exposure to exhaust fumes and noise and also to save fuel.

## F.05 CONTROLLED DESCENT WITH HEAVY LOADS

### Descending with loads over 150 kg:

1. Ensure that an appropriate backup device is used that is approved for 200 kg/2 persons, alternatively two independent backup systems can be used.
2. Make an HMS with the outgoing rope on the Friction Brake as shown (right).
3. Ensure that there is no slack rope between the rope guide and the Friction Brake.
4. Hold the rope below the Friction Brake firmly and pull in the descending lever.
5. Always control your speed while descending and avoid sudden braking, this to prevent high dynamic loading.

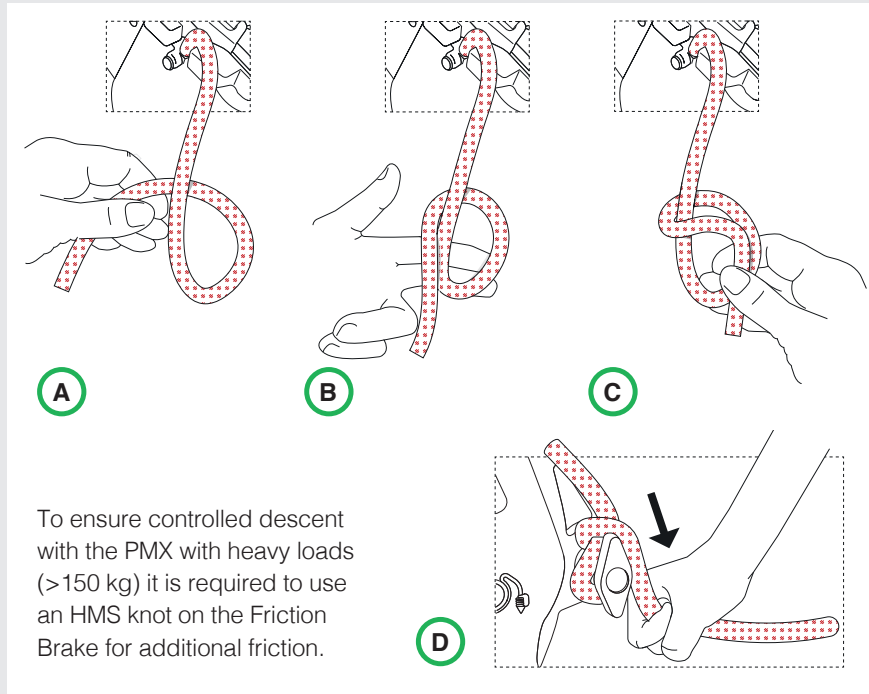

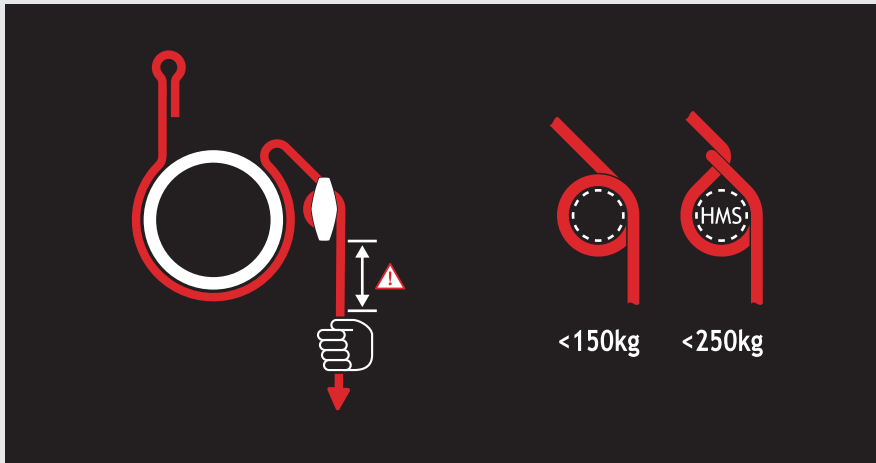

**Always use the Friction Brake when descending with the Ascender:**

**Load < 150 kg:** Simply wind the rope around the bolt 1 or 2 times depending on friction required

**Load > 150-250 kg:** An HMS knot must be used for optimum braking and control whilst descending

**! CAUTION**

Always descend in a controlled manner by using the Friction Brake for additional friction on the outgoing rope and holding it firmly with your right hand.

Keep your hands away from the Friction Brake. Ensure that hair, clothing or any loose items are not allowed to become caught.

## F.06 TWISTED ROPE AND ROTATION

Ensure, especially when descending, that the rope runs untwisted into the Ascender. Twisted ropes caught into the Rope Guide can cause a rope jam and can, in rare cases, result in rope damage.

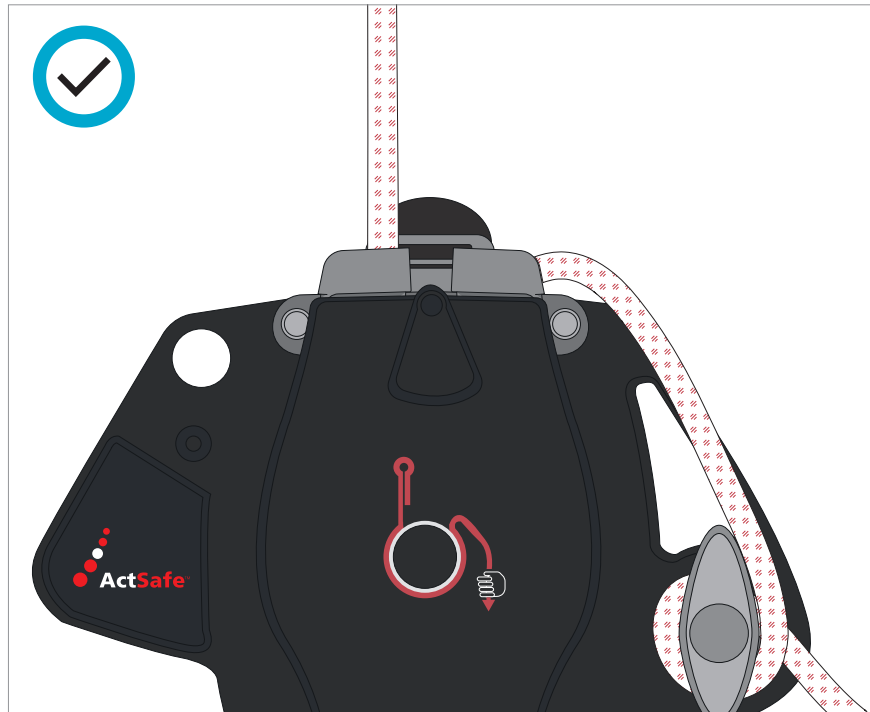

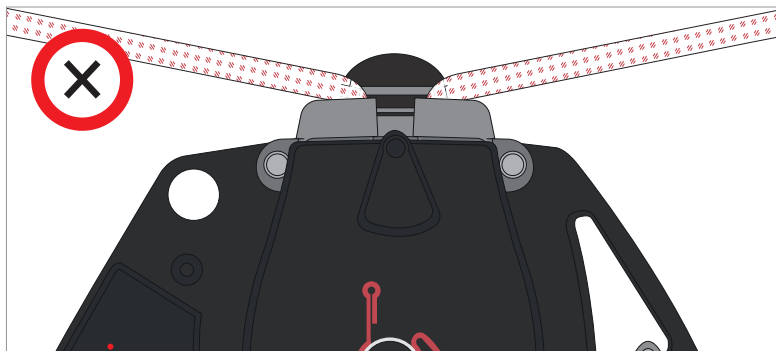

The dead rope must never be loaded. Do not build tramways using the primary rope as shown in the picture.

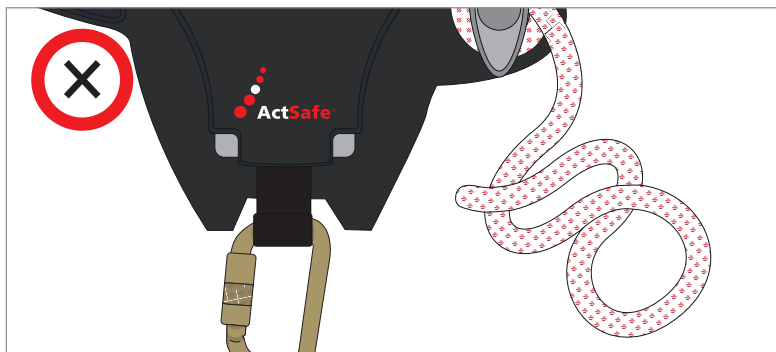

Stop immediately when a rope twist is observed, untwist and organise the rope before continuing.



## CAUTION

When descending, make sure the rope is fed neatly into the rope grab so that there are no kinks or twists in the rope. Take special care when using long ropes to prevent twists or kinks. Good rope management is ESSENTIAL.



## RECOMMENDATION

When descending, hold the rope entering the Ascender to prevent it from running twisted into the Ascender.

## F.07 CHECKLIST BEFORE AND AFTER USE

It is important to carry out a check on the Ascender before and after every use. Check the Ascender thoroughly and in accordance with your training.

If you are in any doubt about the condition of the Ascender, do not use it and contact your ActSafe supplier or ActSafe directly.

### ✓ Engine Inspection

Check following points on the Honda Engine:

- » Sufficient Fuel level
- » Correct Oil Level
- » Clean Air Filter
- » Starting engine
- » Throttle
- » Turning of the Engine with Engine Switch

### ✓ Brake Testing

Check following points on the Honda Engine:

- 1.** Attach the Ascender to a rigged rope, in a non-exposed location
- 2.** Connect backup system and Ascender to harness and ascend 50 cm off the ground and stop the Engine
- 3.** The Ascender should stay in the same position without slowly descending by itself
- 4.** Descend slowly, just before touching the ground release the Braking Lever

The Ascender should stop immediately. If the brake is slipping do not use the Ascender and get in touch with your ActSafe distributor.



**A****B****C****D**

### Visual inspection of load-bearing parts

- » Check Rope Guide (A) for obvious damage or deformation. Rope guide should not be bent and must fit accurately with the Rope Cover. Check for excessive wear, see indicator marking
- » Unlock and open Rope Cover and check for deformation, excessive wear or any sharp edges
- » Check Rope Wedge (B) for deformation or any visible damage. The rope wedge should be centered on the base of the rope grab
- » Check Rope Grab (C) for obvious damage or wear
- » Put a rope into the Ascender and close the Rope Cover. The cover should lock in position with a clicking sound
- » Check the Connection Sling for wear or any damage (D) especially at the sling bolt and karabiner loop

## F.08 TRANSPORTATION

Carry the Ascender by the Lifting Handle with the Engine off and the Silencer away from your body.

Before normal transport in the box, which gives the Ascender optimum protection, switch off and allow the winch to cool at least for 15 minutes.

For longer transportations make sure that the fuel tank is empty.

Always make sure the Ascender is secure before being transported in a vehicle.

## F.09 STORAGE

Depending on the region where you operate your winch, fuel formulations may deteriorate and oxidize rapidly. Fuel deterioration and oxidation can occur in as little as 30 days and may cause damage to the carburetor and/or fuel system. In case of prolonged storage ActSafe recommends to remove the fuel from the Fuel Tank and Carburetor.

If the Ascender is to be stored with gasoline in the Fuel Tank and Carburetor, it is important to reduce the hazard of gasoline vapourignition. Select a well ventilated area.

Always clean and dry the Ascender and the transportation box before putting it away for storage.

Store the Ascender in a cool and dry place. It can be stored in the transportation box, make sure it is dry.

# G

## SERVICE & MAINTENANCE

Maintenance & cleaning  
of the Ascender

**G.01**

Engine maintenance

**G.02**

Trouble-shooting guide

**G.03**

# G

## G.01 MAINTENANCE & CLEANING OF THE ASCENDER

**Only use original spare parts and materials recommended and supplied by ActSafe Systems.**

### **Basic Inspection Guidance for users and third party inspection:**

To be used safely, each Ascender should meet following requirements at all times:

- » No obvious damage or excessive wear on Ascender and its components, as described in F.08 Checklist.
- » Basic function test of Ascender including Engine start, ascending, descending, Engine stop.
- » 1,25 x SWL dynamic load test; descending full speed and then stop with max 10 cm slippage
- » 1,5 x SWL static load test; no slippage allowed

### **i RECOMMENDATION**

Go through "Checklist before and after usage" at every maintenance to increase the safety for the user/s of the product.

Clean the unit regularly (the performance will be affected negatively by excessive dust, clogged parts etc). Check the karabiners for oxidation. Clean and lubricate if needed. Check the engine oil, replace if needed. Check the air filter, clean or replace if needed.



### RECOMMENDATION

Remove the ignition cable before service. Do this to avoid accidental start-up during maintenance work.

Keep the engine cylinder fins and control parts free from dirt and other foreign substances, which could affect the revolution speed.

### Clean the Ascender of salt water/dirt

Clean and dry the Ascender with a wet cloth or brush after use, removing all moisture and dirt.

Dry dust can be removed with compressed air.

Clean the karabiner thoroughly, lubricate with thin oil.



### Note

Do not use running water or any degreasing agent, never use a high-pressure washer!

## G.02 ENGINE MAINTENANCE

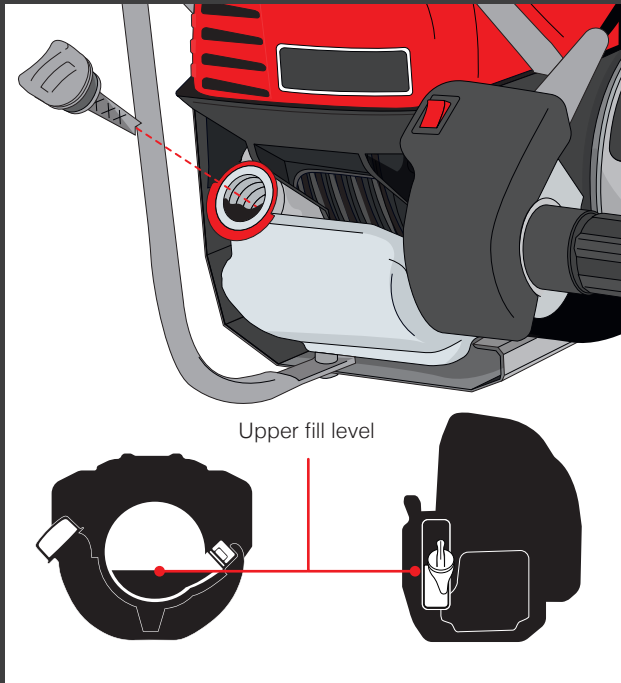

### Oil level check and change

Check the engine oil level before each use, or every 10 hours if operated continuously. Check the engine oil level with engine stopped and in a level position.

- » Remove the oil filler cap/dipstick and wipe it clean.
- » Insert and remove the oil filler/dipstick without screwing it into the oil filler neck, then remove it to check the oil level shown on the dipstick.
- » If the oil level is near or below the lower limit mark on the dipstick, fill to the bottom edge of the oil fill hole with SEA 10w-30 oil. To avoid overfilling or underfilling, be sure the engine is in a level position, as shown, while adding oil.
- » Reinstall the oil filler cap/dipstick and tighten securely.



### RECOMMENDATION

Drain the used oil when the engine is warm.  
Warm oil drains quickly and completely.

**For full information about the engine maintenance points and schedule, check the included owner's engine manual.**

**Be aware:** First oil change is required after first 10 hours of running the engine!  
(Normal service period 50 hours/6 months)



**NOTE**

Change the oil regularly to prolong the lifetime of the engine. NOTE: Running the engine with a low oil level can cause engine damage.

**FUEL FILLER CAP**

**OIL FILLER NECK**

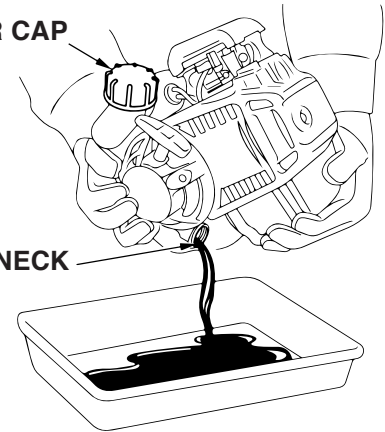

**NOTE**

First oil change is required after first 10 hours of running the engine! (Normal service period 50 hours/6 month.

### **Carburetor**

The Carburetor has a fixed setting for running at sea level. Special carburetor jets can be installed in the carburetor when operating the Ascender at higher altitudes (> 2500 m).

### **Air Filter**

The air filter should be cleaned daily or more often if working in exceptionally dirty areas in order to avoid problems such as:

- » Carburetor malfunctions
- » Starting problems
- » Engine power reduction
- » Unnecessary wear on the engine parts
- » Abnormal fuel consumption

### **Spark plug**

The spark plug can have deposits on the electrodes, which may result in malfunction and/or starting difficulties. The spark plug condition is influenced by:

- » A dirty air filter
- » Hard-running conditions

In some areas, local legislation requires using a resistor spark plug to suppress ignition signals. If the engine was originally equipped with a resistor spark plug, you have to choose the same type of spark plug whenever you replace it.



### **Fuel**

95 Octane fuel is recommended for use in the engine. Aspen fuel may also be used. Do not mix these types of fuel since it can cause a clogged fuel filter.



## G.03 TROUBLESHOOTING GUIDE

If you need further assistance or are in any doubt please contact ActSafe Systems or your approved ActSafe distributor.

PROBLEM	PROBABLE CAUSE	REMEDY
<b>The engine does not start</b>	Empty tank	Refuel the Ascender
	Ignition cable loose	Reattach the ignition cable to the spark plug
	Wrong fuel	Empty the tank, clean and refuel the Ascender
	Too cold	Use choke
	Flooded engine	Turn down choke and wait 10 minutes and try again
	Dirty Spark plug	Clean spark plug

PROBLEM	PROBABLE CAUSE	REMEDY
<b>The engine dies</b>	Vacuum in fuel tank	Open valve in fuel lid (Contact ActSafe) or replace fuel cap
<b>The grab on the rope is poor, the rope slips</b>	Rope connected incorrectly	Reconnect the rope
	The rope is not suitable for the Ascender	Change the rope
	The rope grab is worn	The Ascender is in need of repair and service, contact ActSafe or an approved distributor
<b>The rope cover does not close</b>	Rope not loaded correctly	Open rope cover and check if rope is fitted correctly
	Dirt in rope cover	Clean rope cover and locking mechanism
	Damaged rope cover	The ascender is in need of repair and service, contact ActSafe or an approved distributor

**PROBLEM**

## PROBABLE CAUSE

## REMEDY

<b>Descending too fast</b>	Heavy load (>150 kg)	Put the braking rope with an HMS knot around the friction brake.
	New Rope	Put the braking rope a second time around the friction brake, or use HMS knot.
<b>The lifting capacity is notably weak</b>	The fuel is wrong	Change to recommended fuel
	The winch is being used at high altitude	High altitude will result in loss of performance. The engine can be equipped for use at high altitude. Contact ActSafe or an approved distributor
	The engine is in bad condition	Service the engine





## **POWER ASCENDERS WARRANTY TERMS**

Warranty terms

---

**H.01**

## H.01 WARRANTY TERMS

ActSafe Systems AB ("ActSafe") guarantees that the PMX Power Ascender ("Product") purchased has no defects due to the use of faulty parts or poor workmanship during its manufacture. This is subject to the terms of the limited warranty ("Warranty") given below.

- » Any claim will have to be made within the warranty period which is one year from delivery unless otherwise agreed.
- » ActSafe will repair or, if necessary in ActSafe's opinion, replace any defective parts and correct any problems resulting from poor workmanship, free of charge.
- » ActSafe reserves the right to use reconditioned parts with performance parameters equal to those of new parts in connection with any services performed under the Warranty.

### **Claim under ActSafe's warranty**

Claims under ActSafe's Warranty may be made only by direct customers of ActSafe who, upon ActSafe's request, can present the original sales invoice from ActSafe. The Warranty is not transferable from one user or customer to another.

**The Warranty does not apply if:**

- » A damage or defect has occurred due to physical breakage, electrical faults external to the Product, water penetration of the Product, abuse or events of force majeure.
- » The Product is modified, maintained or repaired by a party not authorized by ActSafe.
- » The Product is maintained and operated in ways other than recommended by ActSafe.
- » The serial number stickers have been removed or tampered with.
- » A non-ActSafe certified product is added to the Product.

**Warranty Limitations**

The Warranty does not extend to parts or Products requiring replacement due to normal wear and tear, corrosion, rust, stain, etc.

Any service, repair or replacement outside the scope of the Warranty shall be subject to the rates and terms of the ActSafe approved service centre performing such service.

ActSafe disclaims all other warranties, express or implied or statutory, including, but not limited to the implied warranties of merchantability or fitness for a particular purpose. Any implied warranty that may be imposed by applicable law is limited to the duration of this Warranty.

**Limited liability and applicable law**

The customer agrees that repair or replacement, as applicable, under the warranty services described herein are the sole and exclusive remedies with respect to any breach of the Warranty.

In no case shall ActSafe be liable for any indirect, incidental, special or consequential loss or damage of whatsoever nature.

ActSafe's sales and delivery of Products, as well as this Warranty, shall be governed by Swedish law, unless otherwise agreed in writing.







## TECHNICAL DATA

Ascender	<b>I.01</b>
Engine	<b>I.02</b>

## I.01 ASCENDER

PERFORMANCE/PART	VALUE	COMMENT
<b>Rope</b>	Personnel Lifting – EN1891A 11 mm, Equipment Lifting – ActSafe ELR	Rope must be soaked before first use. See section C.01.
<b>Safe Working Load (SWL)</b>	250 kg or max 2 persons	
<b>Ascent speed</b>	17 m/min (100 kg load)	
<b>Descending speed</b>	User regulated	Recommended maximum descending speed 0,5 m/sec.
<b>Recommended temperature range</b>	-20 °C til + 40°C	The Ascender can be used at other temperatures as well.
<b>Weight</b>	13 kg	Excluding fuel.
<b>Dimensions</b>	29x28x49 cm	
<b>Transportation box dimensions</b>	33x34x53 cm	
<b>Transportation box weight</b>	20 kg	
<b>Range</b>	750 metre at 100 kg load, with 1 fuel tank	
<b>Max. continuous descending distance</b>	150 m	
<b>Noise level</b>	89 dB	
<b>Max windspeed</b>	12 m/s	Weather conditions should be stable and favourable to not affect the safety of personnel and/or lifting operation

## I.02 ENGINE

PERFORMANCE/PART	VALUE	COMMENT
Engine	Honda GX35	35.8 cc, Forced air-cooled 4-stroke OCH, single cylinder
Reduction rate	131,5:1	
Type		
Spark	CMR5H (NGK)	
Fuel	Unleaded petrol 95-octane or higher.	
Fuel tank	0.65 L	
Engine oil	SAE 10W-30	

**ActSafe Systems AB**

Sagbäcksvägen 13  
SE-43731 Lindome, Sweden

**T:** +46 31 65 56 60

**E:** [info@actsafe.se](mailto:info@actsafe.se)

**W:** [www.actsafe.se](http://www.actsafe.se)

© 2015 ActSafe Systems AB

