

Please note for bespoke sizes please contact our Design Team on +44 (0) 1252 790464

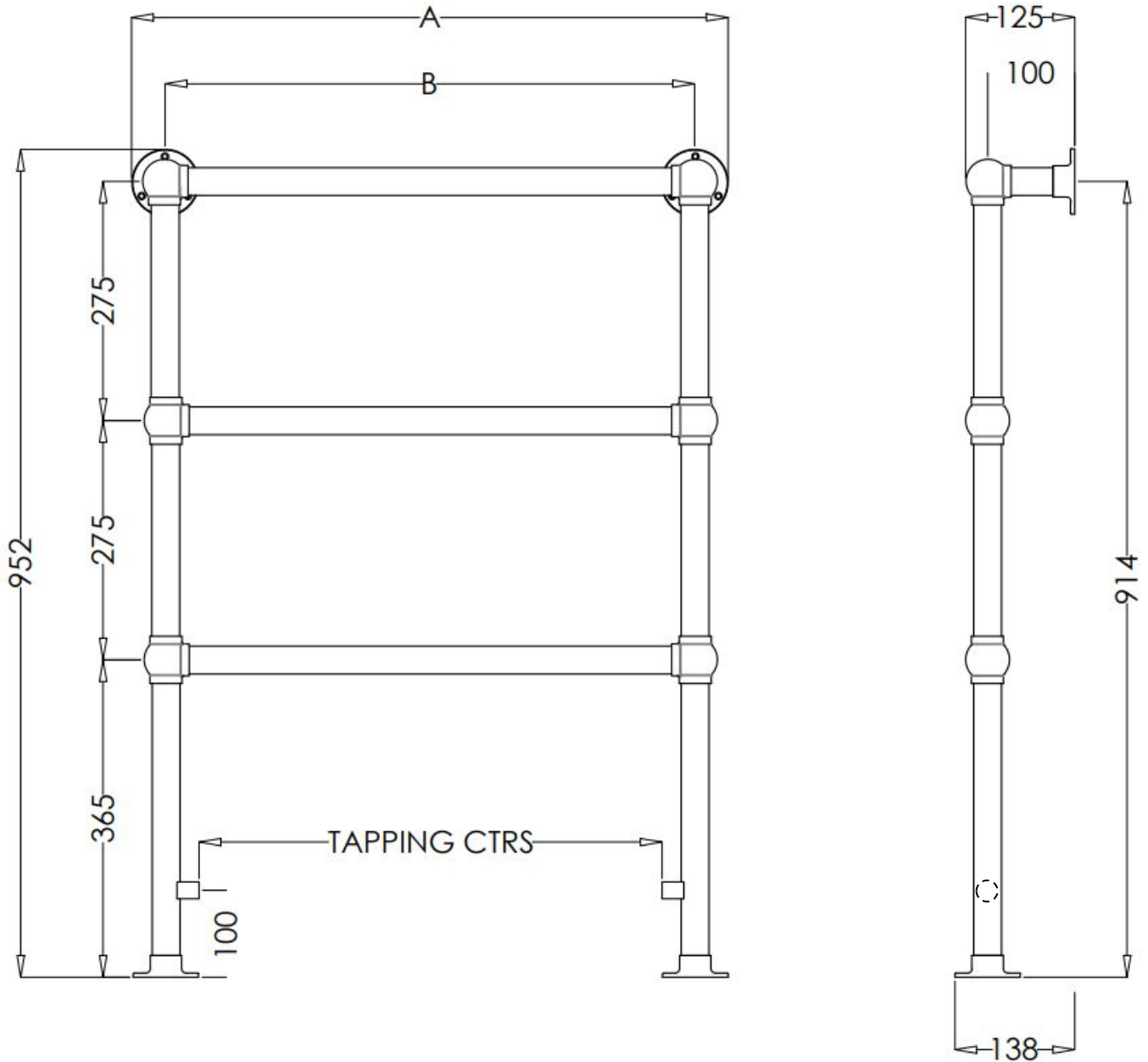

Dimensions. A.	Centres. B.	Tapping ctrs.	BTU's.	Wattage.
400mm	325mm	253mm	470	138
500mm	425mm	353mm	529	155
685mm	610mm	538mm	594	174
837mm	762mm	690mm	669	196
989mm	914mm	842mm	747	219

Test Pressure: 8 bar.
Max. Working Pressure: 5 bar.
Max. Working Temperature: 85°C.
Material: 32mm DZR Brass.
Connections: ½" BSP.
Joints: Hand Brazed Silver Solder.
Finish: Hand Polished.
Plated To: British Standards.
Leak Tested: 3 Times.
Heat Output: In accordance with EN442.

To be installed by a suitably qualified professional in accordance with local water byelaws.
 Our Towel Warmers are suitable for:
 Most Central Heating Systems.
 Hot Water Systems. **(unsuitable for use with column radiator inserts)**
 Dual Fuel Systems.
 Electric only.
Please confirm with your installer/contractor that there is not a water softener fitted on the system prior to installation.
All dimensions are subject to +/- 3 mm tolerance.