

Colonial Needle Presents

Son of a Stitch - SOS1014

Stitch and Thread Suggestions

By
Cynthia D. Thomas

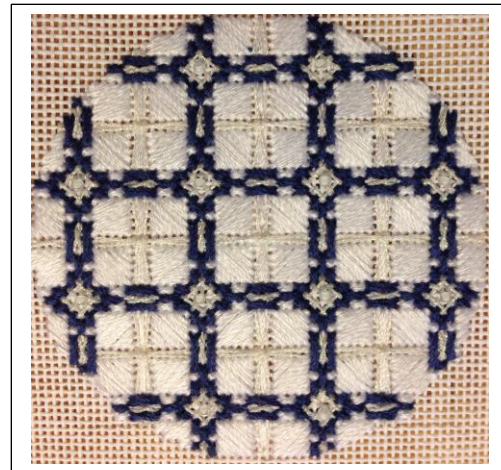

I used one skein, card or spool unless indicated otherwise.

Colonial Needle/Presencia

Mouline

0001 – White

3324 – Navy Blue

Kreinik Manufacturing Co.

#8 Braid

032 - Pearl

Mill Hill Beads

Frosted Glass Beads

60479 – Frosted White

Miscellaneous

Gutermann Invisible thread or beading thread to match

Below is a diagram of one square: The colors on the diagram are the following threads:

Blue lines – Presencia Mouline 3324

Black lines – Presencia Mouline 0001

Orange lines – Kreinik #123 032

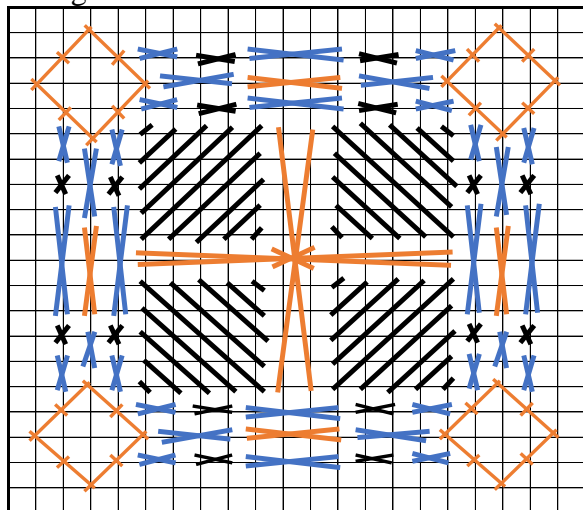

Blue Lines on canvas and on diagram:

Presencia Mouline 3324 – 3 ply – Vertical and Horizontal Elongated Cross Stitches to cover paint.

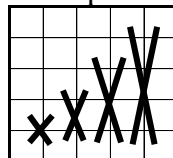

White one canvas, black lines on

diagram: Center of motif - Presencia Mouline 0001 – 3 ply – Scotch. Note: Each side of the Scotch has either a 1x2 or 1x1 elongated cross stitch.

White on canvas, orange lines on diagram – Kreinik #8 032 – 1 strand – Elongated Cross stitch over either 4 or 5 threads on sides.

Center motif – Kreinik #8 032 – 1 strand.

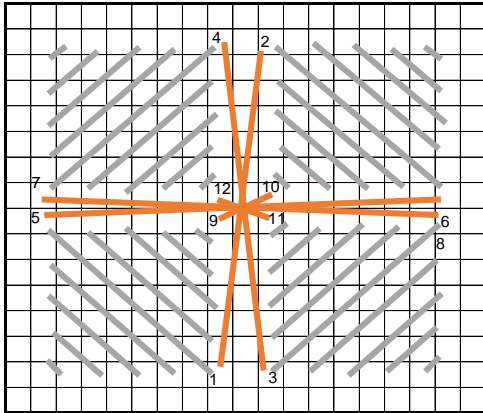

Corner motifs – Kreinik #8 032 – 1 strand.

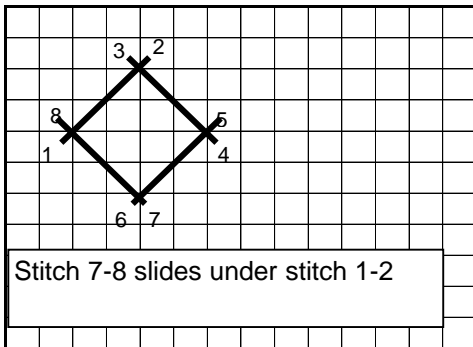

Attach Mill Hill bead 60479 with bead on intersection with hole vertical technique.

