

1 1/2" Elima-Matic Clamped Metallic

with Metallic Center Section

E4

E4 Metallic Pumps

- Aluminum
- Cast Iron
- Stainless Steel

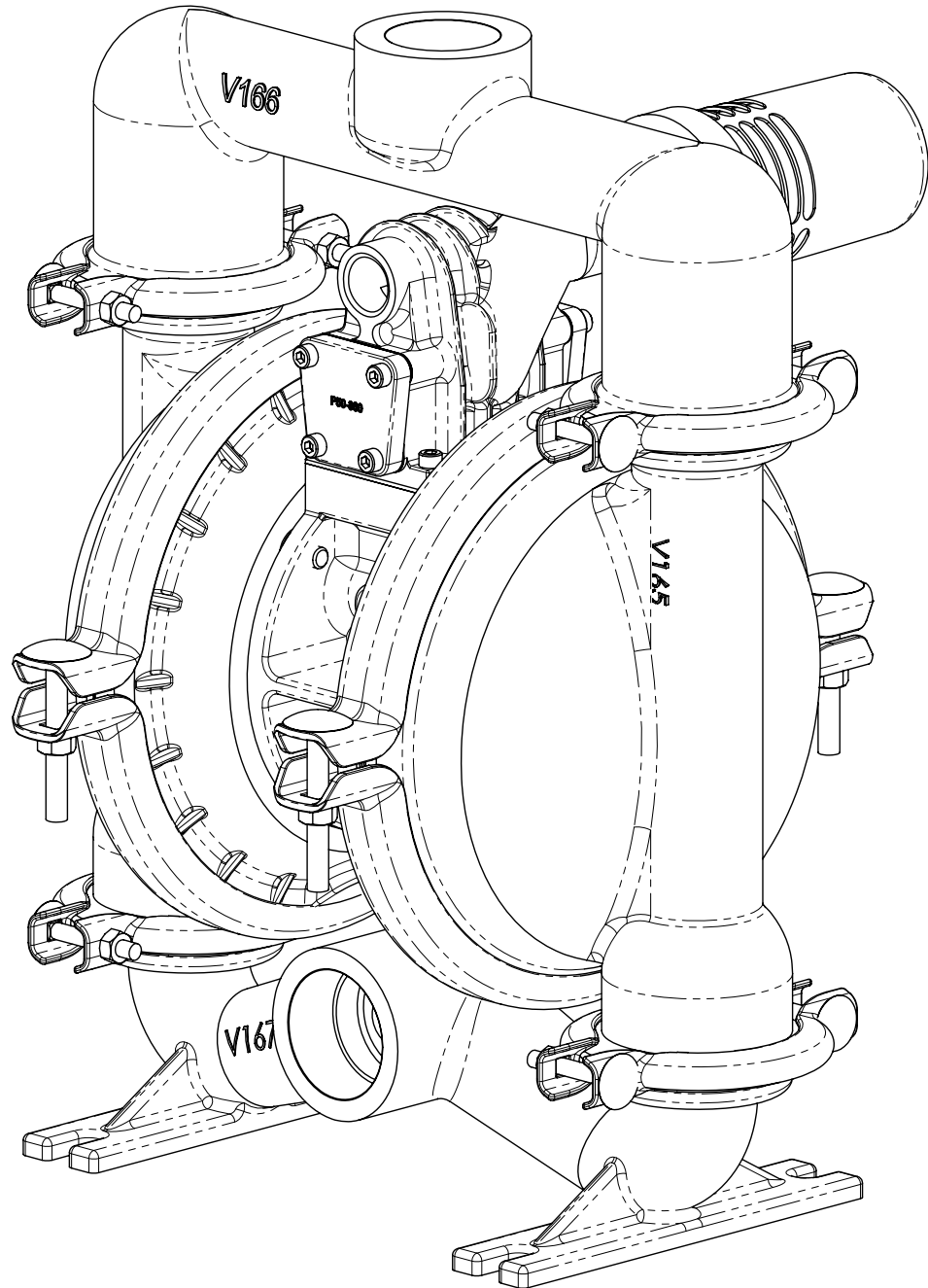

1: PUMP SPECS

2: INSTAL & OP

3: EXP VIEW

4: WARRANTY

Safety Information

IMPORTANT



Read the safety warnings and instructions in this manual before pump installation and start-up. Failure to comply with the recommendations stated in this manual could damage the pump and void factory warranty.



When the pump is used for materials that tend to settle out or solidify, the pump should be flushed after each use to prevent damage. In freezing temperatures the pump should be completely drained between uses.

CAUTION



Before pump operation, inspect all fasteners for loosening caused by gasket creep. Retighten loose fasteners to prevent leakage. Follow recommended torques stated in this manual.



Nonmetallic pumps and plastic components are not UV stabilized. Ultraviolet radiation can damage these parts and negatively affect material properties. Do not expose to UV light for extended periods of time.



WARNING
Pump not designed, tested or certified to be powered by compressed natural gas. Powering the pump with natural gas will void the warranty.

WARNING



When used for toxic or aggressive fluids, the pump should always be flushed clean prior to disassembly.



Before maintenance or repair, shut off the compressed air line, bleed the pressure, and disconnect the air line from the pump. Be certain that approved eye protection and protective clothing are worn at all times. Failure to follow these recommendations may result in serious injury or death.



Airborne particles and loud noise hazards. Wear eye and ear protection.



In the event of diaphragm rupture, pumped material may enter the air end of the pump, and be discharged into the atmosphere. If pumping a product that is hazardous or toxic, the air exhaust must be piped to an appropriate area for safe containment.



Take action to prevent static sparking. Fire or explosion can result, especially when handling flammable liquids. The pump, piping, valves, containers and other miscellaneous equipment must be properly grounded.



This pump is pressurized internally with air pressure during operation. Make certain that all fasteners are in good condition and are reinstalled properly during reassembly.



Use safe practices when lifting

Table of Contents

SECTION 1: PUMP SPECIFICATIONS.....1

- Nomenclature
- Performance
- Materials
- Dimensional Drawings

SECTION 2: INSTALLATION & OPERATION.....5

- Principle of Pump Operation
- Typical Installation Guide
- Troubleshooting

SECTION 3: EXPLODED VIEW.....8

- Composite Drawings
- Parts List
- Materials Code

SECTION 4: WARRANTY & CERTIFICATES12

- Warranty
- EC Declaration of Conformity - Machinery

1: PUMP SPECS

2: INSTAL & OP

3: EXP VIEW

4: WARRANTY

Explanation of Pump Nomenclature

Your Serial #: (fill in from pump nameplate) _____

Your Model #: _____
(fill in from pump nameplate)

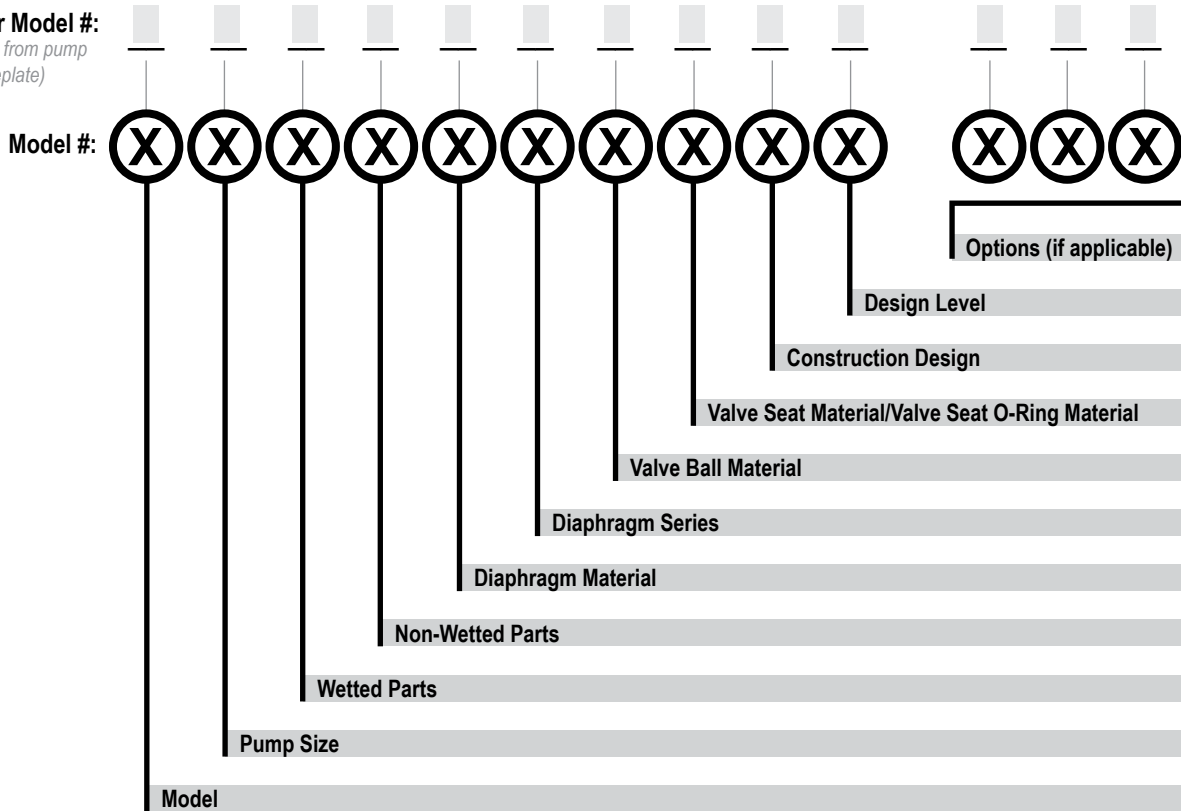

Model

E Elima-Matic
U Ultra-Matic
V V-Series
RE AirVantage

Pump Size

6 1/4"
8 3/8"
5 1/2"
7 3/4"
1 1"
4 1-1/4" or 1-1/2"
2 2"
3 3"

Wetted Parts

A Aluminum
C Cast Iron
S Stainless Steel
H Alloy C
P Polypropylene
K Kynar
G Groundable Acetal
B Aluminum (screen mount)

Non-Wetted Parts

A Aluminum
S Stainless Steel
P Polypropylene
G Groundable Acetal
Z PTFE-coated Aluminum
J Nickel-plated Aluminum
C Cast Iron
Q Epoxy-Coated Aluminum

Diaphragm Material

1 Neoprene
2 Nitrile (Nitrile)
3 FKM (Fluorocarbon)
4 EPDM
5 PTFE
6 Santoprene XL
7 Hytrel
9 Geolast
Y FDA Santoprene

Diaphragm Series

R Rugged
D Dome
X Thermo-Matic
T Tef-Matic (2-piece)
B Versa-Tuff (1-piece)
F FUSION (one-piece integrated plate)

Valve Ball Material Valve

1 Neoprene
2 Nitrile
3 (FKM) Fluorocarbon
4 EPDM
5 PTFE
6 Santoprene XL
7 Hytrel
8 Polyurethane
9 Geolast
A Acetal
S Stainless Steel
Y FDA Santoprene

Seat/Valve Seat O-Ring Material

1 Neoprene
2 Nitrile
3 (FKM) Fluorocarbon
4 EPDM
5 PTFE
6 Santoprene XL
7 Hytrel
8 Polyurethane
9 Geolast
A Aluminum w/ PTFE O-Rings
S Stainless Steel w/ PTFE O-Rings
C Carbon Steel w/ PTFE O-Rings
H Alloy C w/ PTFE O-Rings
T PTFE Encapsulated Silicone O-Rings
Y FDA Santoprene

Construction Design

9 Bolted
0 Clamped

Design Level

A
C

Miscellaneous Options

B BSP Tapered Thread
CP Center Port
ATEX ATEX Compliant
FP Food Processing
SP Sanitary Pump
HP High Pressure
OE Original Elima-Matic
F Flap Valve
HD Horizontal Discharge
3A 3-A Certified
UL UL Listed
OB Oil Bottle

*More than one option may be specified for a particular pump model.

Materials

Material Profile:	Operating Temperatures:	
	Max.	Min.
CAUTION! Operating temperature limitations are as follows:		
Conductive Acetal: Tough, impact resistant, ductile. Good abrasion resistance and low friction surface. Generally inert, with good chemical resistance except for strong acids and oxidizing agents.	190°F 88°C	-20°F -29°C
EPDM: Shows very good water and chemical resistance. Has poor resistance to oils and solvents, but is fair in ketones and alcohols.	280°F 138°C	-40°F -40°C
FKM: (Fluorocarbon) Shows good resistance to a wide range of oils and solvents; especially all aliphatic, aromatic and halogenated hydrocarbons, acids, animal and vegetable oils. Hot water or hot aqueous solutions (over 70°F) will attack FKM.	350°F 177°C	-40°F -40°C
Hytrel®: Good on acids, bases, amines and glycols at room temperatures only.	220°F 104°C	-20°F -29°C
Neoprene: All purpose. Resistance to vegetable oils. Generally not affected by moderate chemicals, fats, greases and many oils and solvents. Generally attacked by strong oxidizing acids, ketones, esters and nitro hydrocarbons and chlorinated aromatic hydrocarbons.	200°F 93°C	-10°F -23°C
Nitrile: General purpose, oil-resistant. Shows good solvent, oil, water and hydraulic fluid resistance. Should not be used with highly polar solvents like acetone and MEK, ozone, chlorinated hydrocarbons and nitro hydrocarbons.	190°F 88°C	-10°F -23°C
Nylon: 6/6 High strength and toughness over a wide temperature range. Moderate to good resistance to fuels, oils and chemicals.	180°F 82°C	32°F 0°C

Polypropylene: A thermoplastic polymer. Moderate tensile and flex strength. Resists strong acids and alkali. Attacked by chlorine, fuming nitric acid and other strong oxidizing agents.	180°F 82°C	32°F 0°C
PVDF: (Polyvinylidene Fluoride) A durable fluoroplastic with excellent chemical resistance. Excellent for UV applications. High tensile strength and impact resistance.	250°F 121°C	0°F -18°C
Santoprene®: Injection molded thermoplastic elastomer with no fabric layer. Long mechanical flex life. Excellent abrasion resistance.	275°F 135°C	-40°F -40°C
UHMW PE: A thermoplastic that is highly resistant to a broad range of chemicals. Exhibits outstanding abrasion and impact resistance, along with environmental stress-cracking resistance.	180°F 82°C	-35°F -37°C
Urethane: Shows good resistance to abrasives. Has poor resistance to most solvents and oils.	150°F 66°C	32°F 0°C
Virgin PTFE: (PFA/TFE) Chemically inert, virtually impervious. Very few chemicals are known to chemically react with PTFE; molten alkali metals, turbulent liquid or gaseous fluorine and a few fluoro-chemicals such as chlorine trifluoride or oxygen difluoride which readily liberate free fluorine at elevated temperatures.	220°F 104°C	-35°F -37°C
<i>Maximum and Minimum Temperatures are the limits for which these materials can be operated. Temperatures coupled with pressure affect the longevity of diaphragm pump components. Maximum life should not be expected at the extreme limits of the temperature ranges.</i>		
Metals:		
Alloy C: Equal to ASTM494 CW-12M-1 specification for nickel and nickel alloy.		
Stainless Steel: Equal to or exceeding ASTM specification A743 CF-8M for corrosion resistant iron chromium, iron chromium nickel and nickel based alloy castings for general applications. Commonly referred to as 316 Stainless Steel in the pump industry.		

For specific applications, always consult the Chemical Resistance Chart.

1: PUMP SPECS

AFTERMARKET PARTS

RIGHT PART, RIGHT NOW

Pumper Parts is your single source for parts that fit Air-Operated Double Diaphragm (AODD) pumps

- Wilden®
- ARO®
- Yamada®

Designed to perform equal to or greater than original equipment manufacture.



Phone: (419) 526-7296
 info@pumperparts.com
 www.pumperparts.com

Pumper Parts and its products are not affiliated with any of the original equipment manufacturers referenced herein. All original equipment manufacturers' names, colors, pictures, descriptions and part numbers are used for identification purposes only. Pumper Parts® is a registered trade name of IDEX Corporation. All other trademarks, registered trademarks and product names are the property of their respective owners. Yamada® is a registered trademark of Yamada Corporation. ARO® is a registered trade name of Ingersoll-Rand Company. Wilden® is a registered trade name of Wilden Pump and Engineering Company, a Dover Resources Company.

Performance

E4 1 1/4" Clamped Pump ELASTOMERIC AND TPE FITTED

Flow Rate

Adjustable to 0-71 gpm (268 lpm)

Port Size

Suction 1 1/2" NPT

Discharge 1 1/4" NPT

Air Inlet 1/2" NPT

Air Exhaust 3/4" NPT

Suction Lift

Dry 19' (5.8 m)

Wet 31' (9.4 m)

Max Solid Size (Diameter)

. 3/16" (4.76 mm)

Max Noise Level 101 dB(A)

Shipping Weights

Aluminum 55 lbs (25 kg)

Cast Iron 95 lbs (43 kg)

Stainless Steel 92 lbs (42 kg)

1: PUMP SPECS

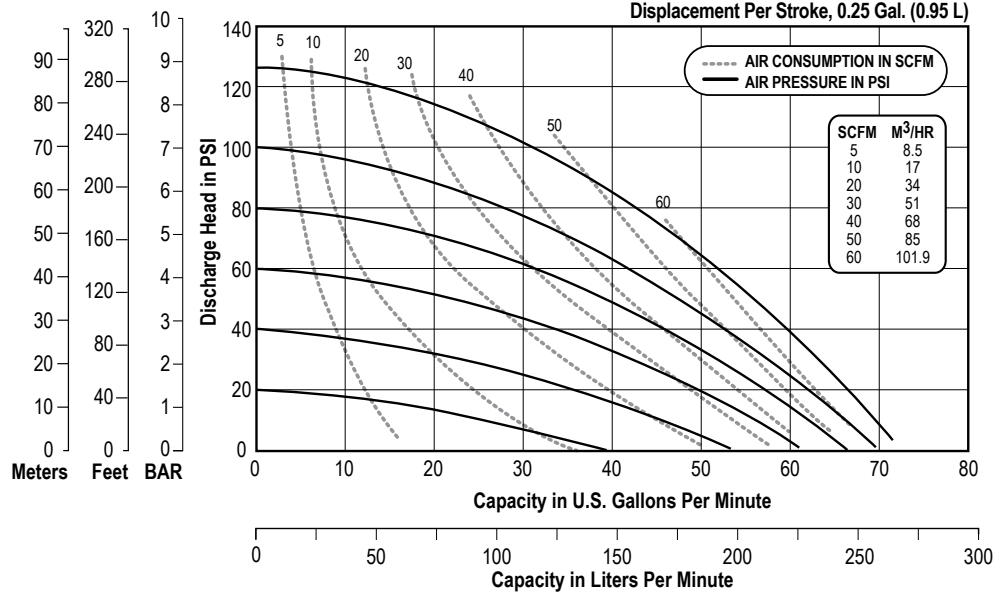

NOTE: Performance based on the following: elastomeric fitted pump, flooded suction, water at ambient conditions. The use of other materials and varying hydraulic conditions may result in deviations in excess of 5%.

E4 1 1/4" Clamped Pump PTFE Fitted

Flow Rate

Adjustable to 0-64 gpm (242.3 lpm)

Port Size

Suction 1 1/2" NPT

Discharge 1 1/4" NPT

Air Inlet 1/2" NPT

Air Exhaust 3/4" NPT

Suction Lift

Dry 12' (3.7 m)

Wet 29' (8.8 m)

Max Solid Size (Diameter)

. 3/16" (4.76 mm)

Max Noise Level 98 dB(A)

Shipping Weights

Aluminum 55 lbs (25 kg)

Cast Iron 95 lbs (43 kg)

Stainless Steel 92 lbs (42 kg)

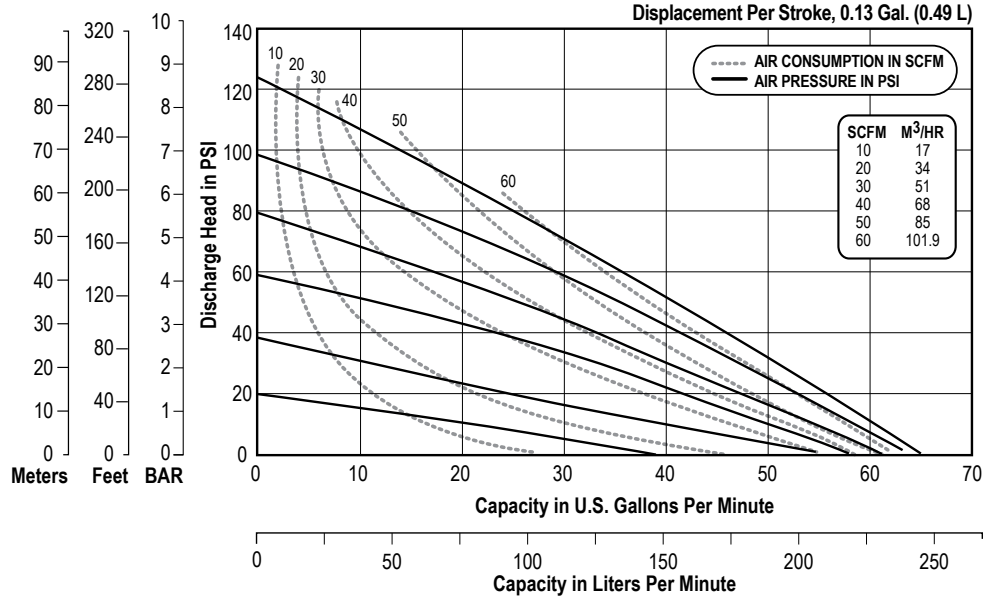

NOTE: Performance based on the following: PTFE fitted pump, flooded suction, water at ambient conditions. The use of other materials and varying hydraulic conditions may result in deviations in excess of 5%.

Dimensional Drawings

E4 Metallic Clamped - Aluminum

Dimensions in inches (metric dimensions in brackets)

The dimensions on this drawing are for reference only. A certified drawing can be requested if physical dimensions are needed.

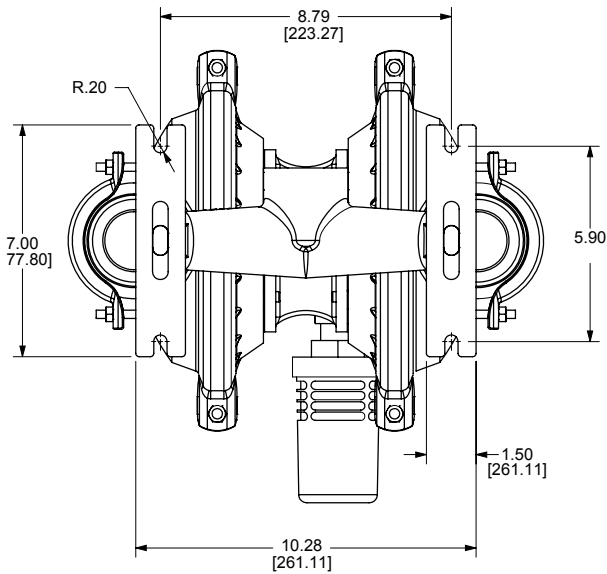
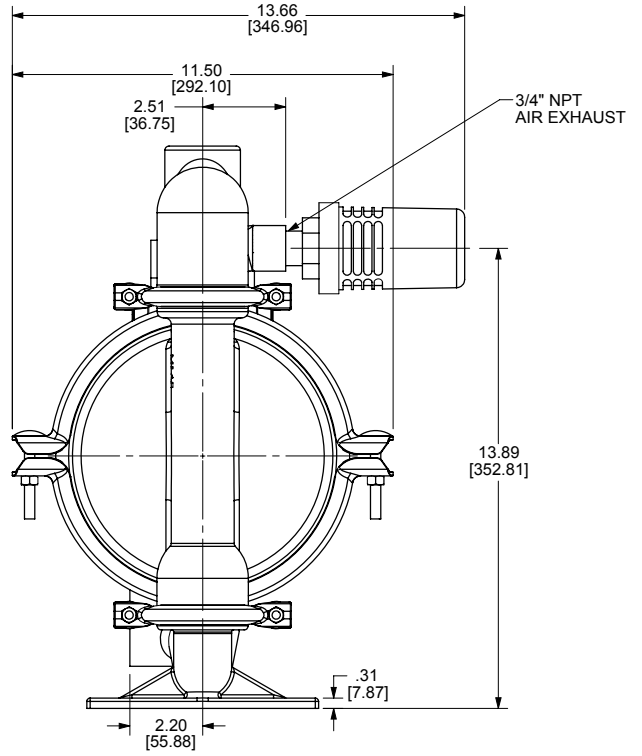
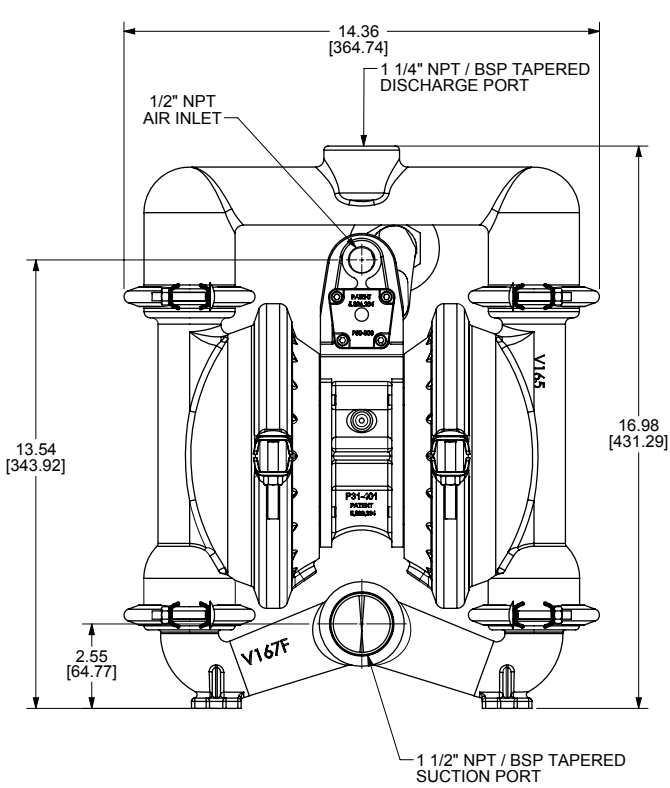

BOTTOM VIEW

1: PUMP SPECS

Dimensional Drawings

E4 Metallic Clamped - Base Mounted Aluminum

Dimensions in inches (metric dimensions in brackets)

The dimensions on this drawing are for reference only. A certified drawing can be requested if physical dimensions are needed.

1: PUMP SPECS

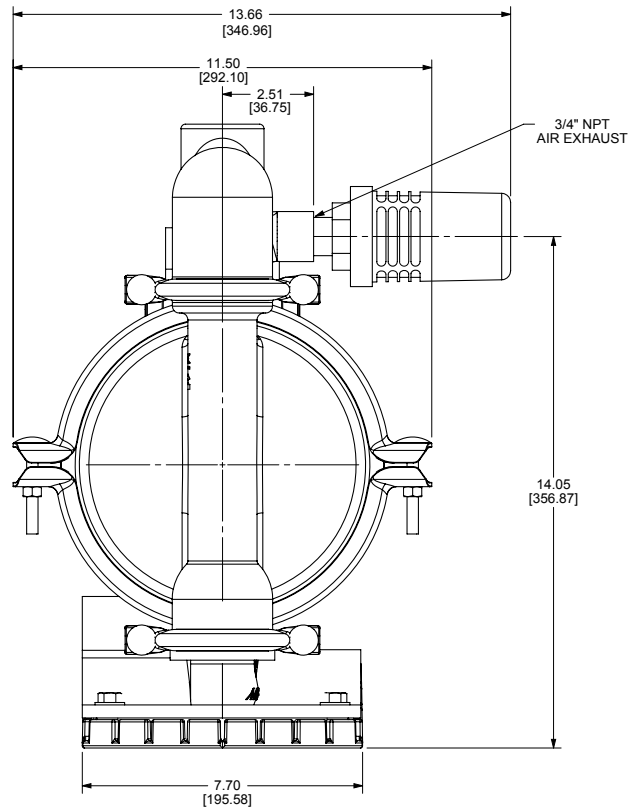
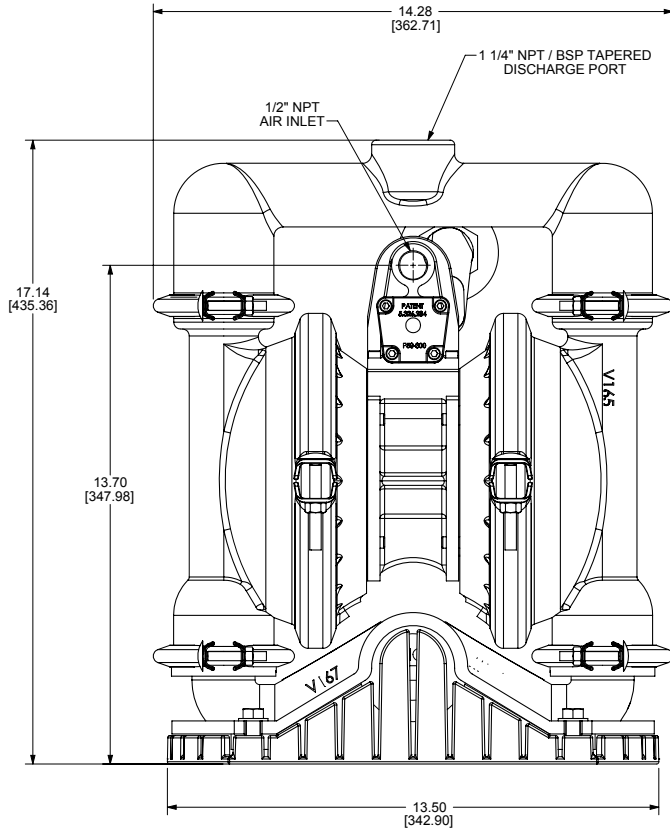

Dimensional Drawings

E4 Metallic Clamped - Cast Iron

Dimensions in inches (metric dimensions in brackets)

The dimensions on this drawing are for reference only. A certified drawing can be requested if physical dimensions are needed.

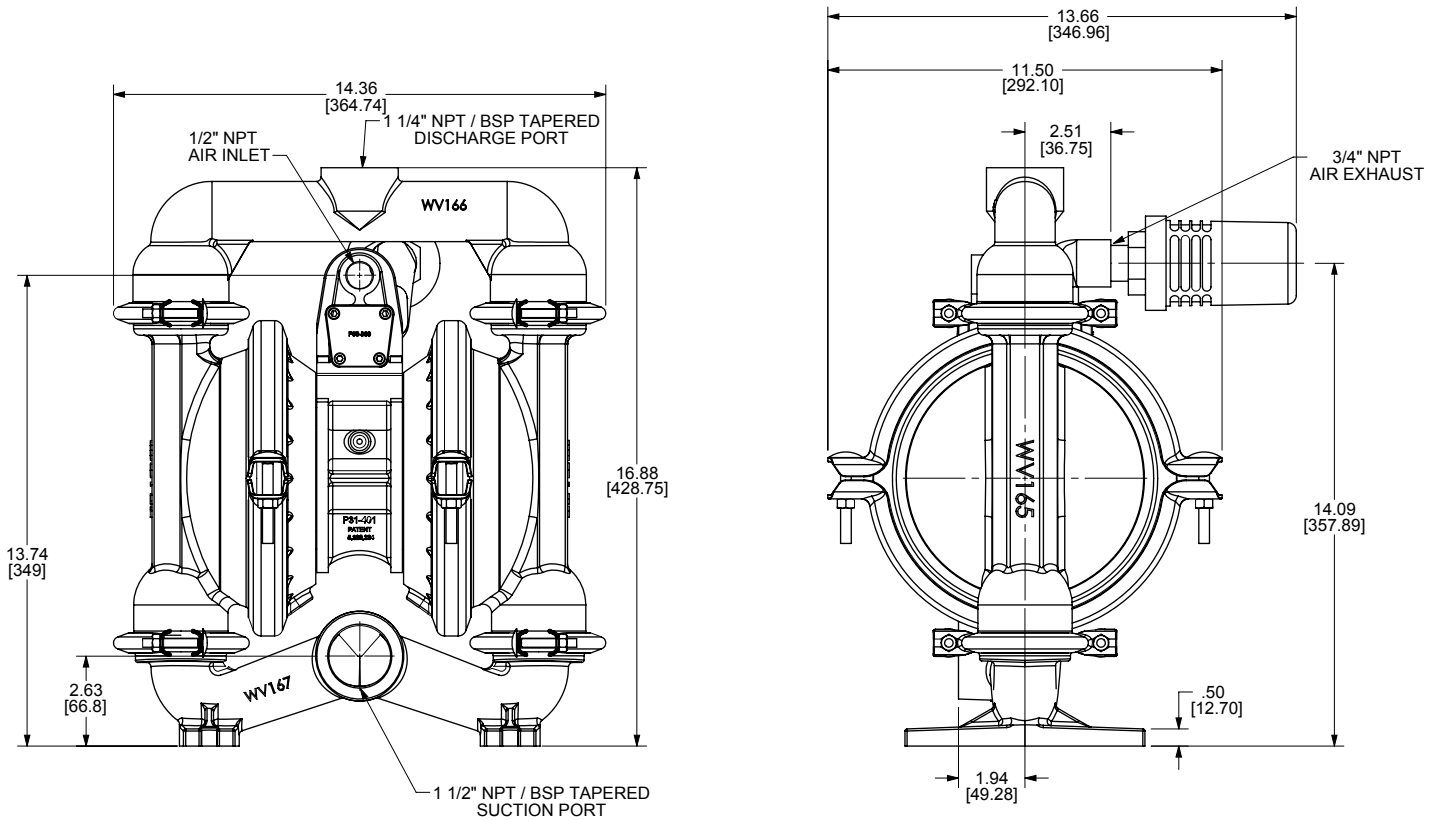

1: PUMP SPECS

BOTTOM VIEW

Dimensional Drawings

E4 Metallic Clamped - Stainless Steel

Dimensions in inches (metric dimensions in brackets)

The dimensions on this drawing are for reference only. A certified drawing can be requested if physical dimensions are needed.

1: PUMP SPECS

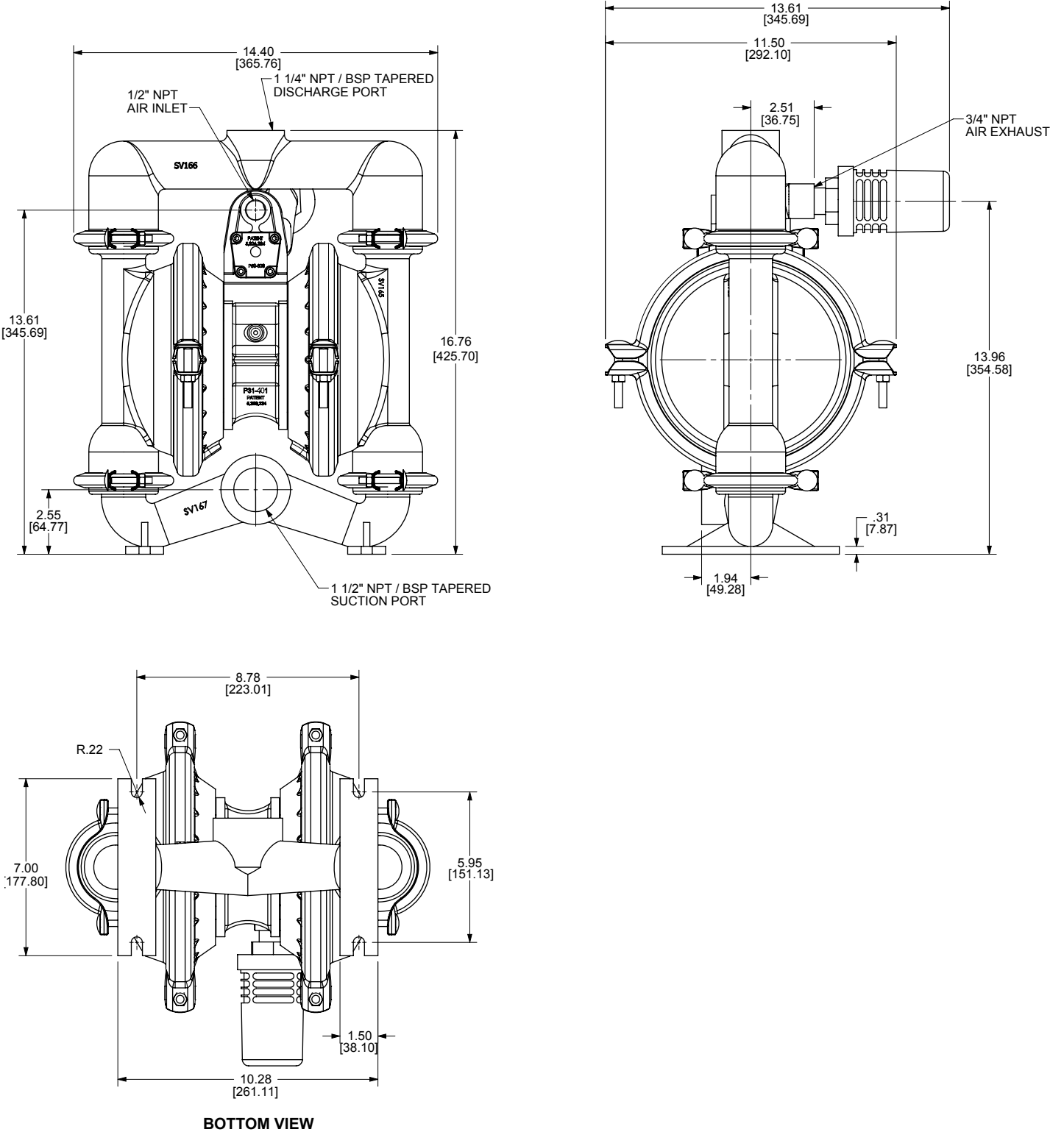

Principle of Pump Operation

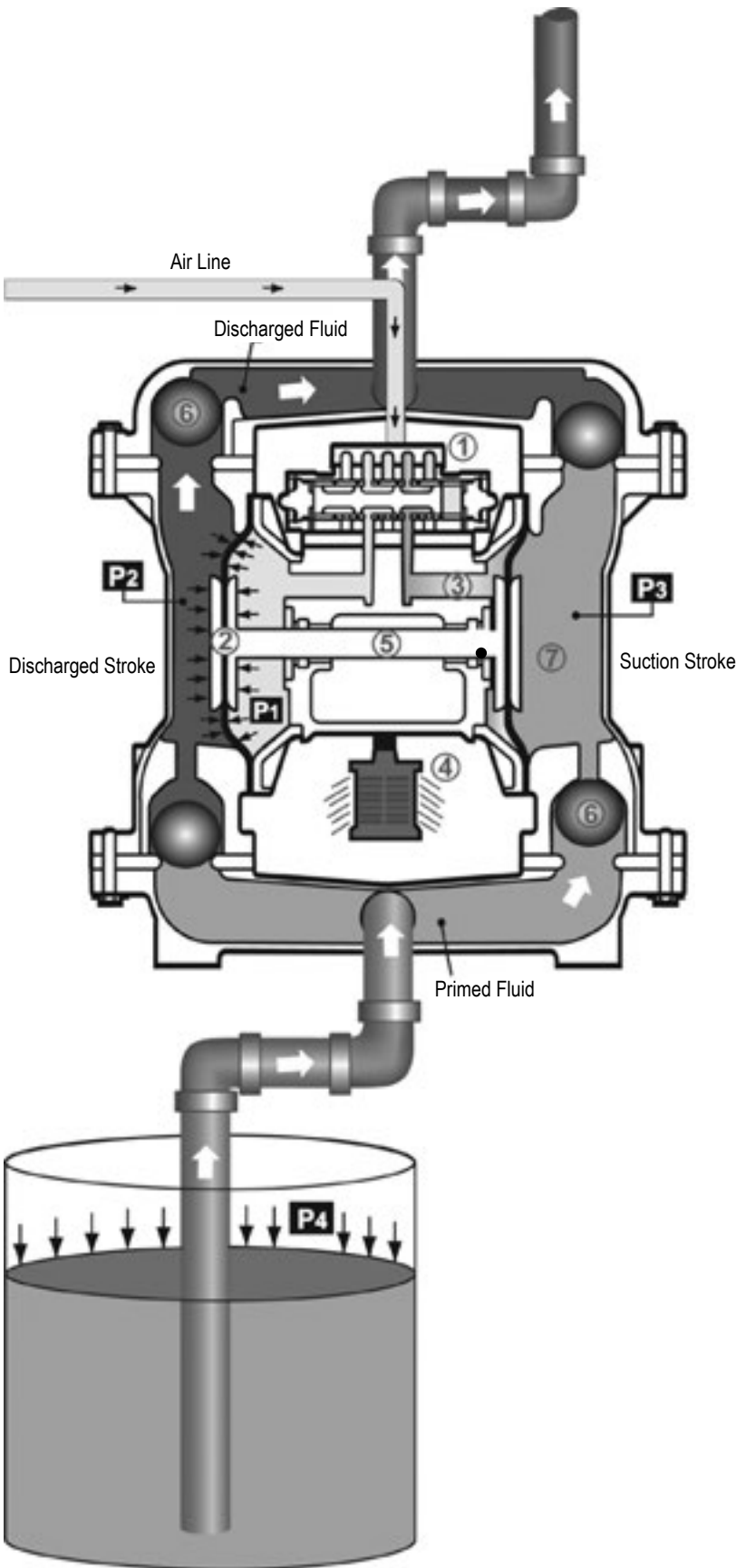

Air-Operated Double Diaphragm (AODD) pumps are powered by compressed air or nitrogen.

The main directional (air) control valve ① distributes compressed air to an air chamber, exerting uniform pressure over the inner surface of the diaphragm ②. At the same time, the exhausting air ③ from behind the opposite diaphragm is directed through the air valve assembly(s) to an exhaust port ④.

As inner chamber pressure (P1) exceeds liquid chamber pressure (P2), the rod ⑤ connected diaphragms shift together creating discharge on one side and suction on the opposite side. The discharged and primed liquid's directions are controlled by the check valves (ball or flap)⑥ orientation.

The pump primes as a result of the suction stroke. The suction stroke lowers the chamber pressure (P3) increasing the chamber volume. This results in a pressure differential necessary for atmospheric pressure (P4) to push the fluid through the suction piping and across the suction side check valve and into the outer fluid chamber ⑦.

Suction (side) stroking also initiates the reciprocating (shifting, stroking or cycling) action of the pump. The suction diaphragm's movement is mechanically pulled through its stroke. The diaphragm's inner plate makes contact with an actuator plunger aligned to shift the pilot signaling valve. Once actuated, the pilot valve sends a pressure signal to the opposite end of the main directional air valve, redirecting the compressed air to the opposite inner chamber.

SUBMERGED ILLUSTRATION

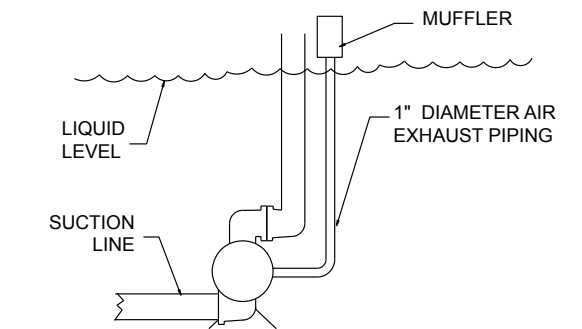

Pump can be submerged if the pump materials of construction are compatible with the liquid being pumped. The air exhaust must be piped above the liquid level. When the pumped product source is at a higher level than the pump (flooded suction condition), pipe the exhaust higher than the product source to prevent siphoning spills.

Recommended Installation Guide

Available Accessories:

1. Surge Suppressor
2. Filter/Regulator
3. Air Dryer

Note: Surge Suppressor and Piping must be supported after the flexible connection.

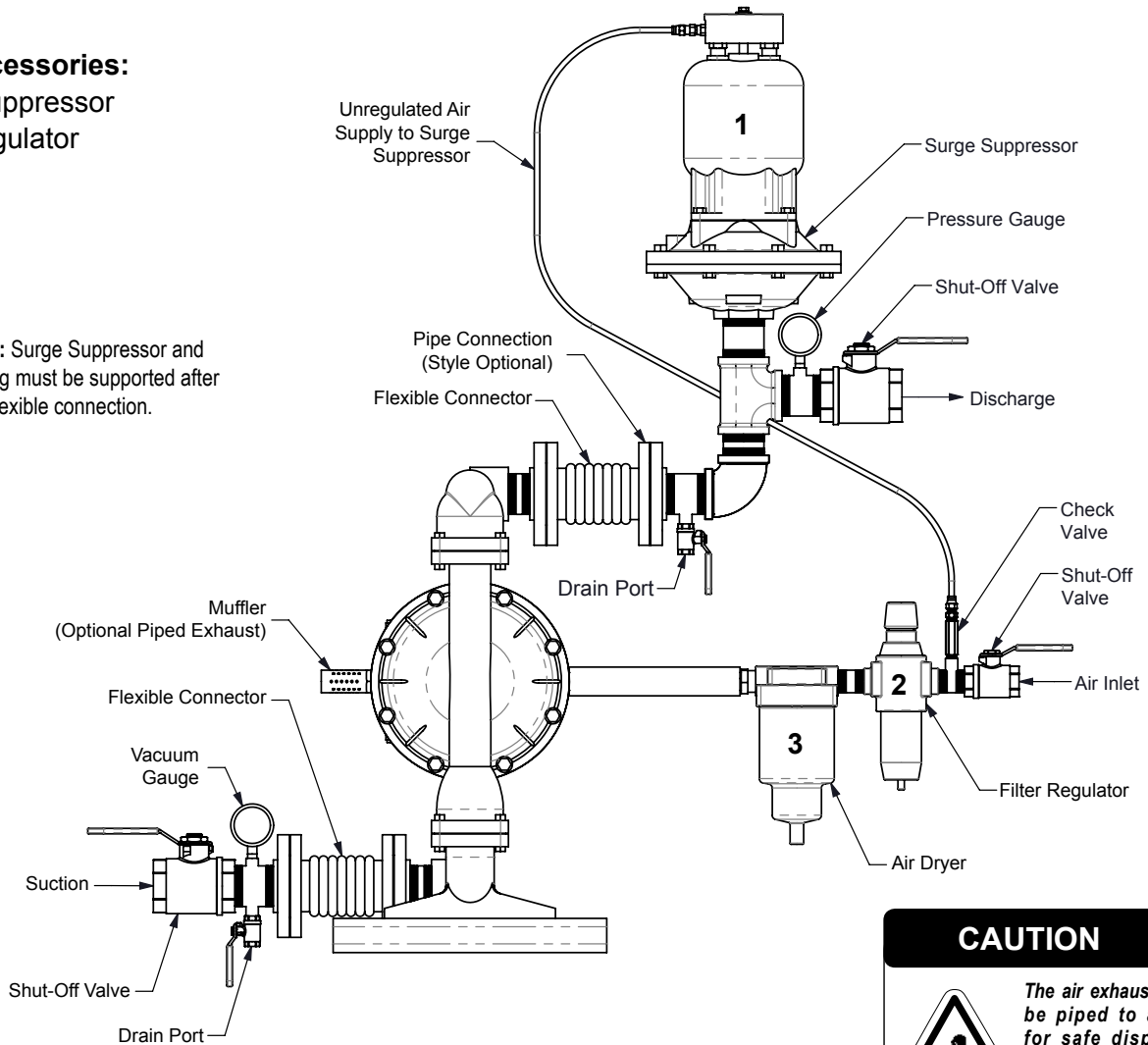

CAUTION



The air exhaust should be piped to an area for safe disposition of the product being pumped, in the event of a diaphragm failure.

Installation And Start-Up

Locate the pump as close to the product being pumped as possible. Keep the suction line length and number of fittings to a minimum. Do not reduce the suction line diameter.

Air Supply

Connect the pump air inlet to an air supply with sufficient capacity and pressure to achieve desired performance. A pressure regulating valve should be installed to insure air supply pressure does not exceed recommended limits.

Air Valve Lubrication

The air distribution system is designed to operate **WITHOUT** lubrication. This is the standard mode of operation. If lubrication is desired, install an air line lubricator set to deliver one drop of SAE 10 non-detergent oil for every 20 SCFM (9.4 liters/sec.) of air the pump consumes. Consult the Performance Curve to determine air consumption.

Air Line Moisture

Water in the compressed air supply may cause icing or freezing of the exhaust air, causing the pump to cycle erratically or stop operating. Water in the air supply can be reduced by using a point-of-use air dryer.

Air Inlet And Priming

To start the pump, slightly open the air shut-off valve. After the pump primes, the air valve can be opened to increase air flow as desired. If opening the valve increases cycling rate, but does not increase the rate of flow, cavitation has occurred. The valve should be closed slightly to obtain the most efficient air flow to pump flow ratio.

Troubleshooting Guide

Symptom:	Potential Cause(s):	Recommendation(s):
Pump Cycles Once	Deadhead (system pressure meets or exceeds air supply pressure).	Increase the inlet air pressure to the pump. Pump is designed for 1:1 pressure ratio at zero flow. (Does not apply to high pressure 2:1 units).
	Air valve or intermediate gaskets installed incorrectly.	Install gaskets with holes properly aligned.
	Bent or missing actuator plunger.	Remove pilot valve and inspect actuator plungers.
Pump Will Not Operate / Cycle	Pump is over lubricated.	Set lubricator on lowest possible setting or remove. Units are designed for lube free operation.
	Lack of air (line size, PSI, CFM).	Check the air line size and length, compressor capacity (HP vs. cfm required).
	Check air distribution system.	Disassemble and inspect main air distribution valve, pilot valve and pilot valve actuators.
	Discharge line is blocked or clogged manifolds.	Check for inadvertently closed discharge line valves. Clean discharge manifolds/piping.
	Deadhead (system pressure meets or exceeds air supply pressure).	Increase the inlet air pressure to the pump. Pump is designed for 1:1 pressure ratio at zero flow. (Does not apply to high pressure 2:1 units).
	Blocked air exhaust muffler.	Remove muffler screen, clean or de-ice, and re-install.
	Pumped fluid in air exhaust muffler.	Disassemble pump chambers. Inspect for diaphragm rupture or loose diaphragm plate assembly.
	Pump chamber is blocked.	Disassemble and inspect wetted chambers. Remove or flush any obstructions.
Pump Cycles and Will Not Prime or No Flow	Cavitation on suction side.	Check suction condition (move pump closer to product).
	Check valve obstructed. Valve ball(s) not seating properly or sticking.	Disassemble the wet end of the pump and manually dislodge obstruction in the check valve pocket. Clean out around valve ball cage and valve seat area. Replace valve ball or valve seat if damaged. Use heavier valve ball material.
	Valve ball(s) missing (pushed into chamber or manifold).	Worn valve ball or valve seat. Worn fingers in valve ball cage (replace part). Check Chemical Resistance Guide for compatibility.
	Valve ball(s)/seat(s) damaged or attacked by product.	Check Chemical Resistance Guide for compatibility.
	Check valve and/or seat is worn or needs adjusting.	Inspect check valves and seats for wear and proper setting. Replace if necessary.
	Suction line is blocked.	Remove or flush obstruction. Check and clear all suction screens or strainers.
	Excessive suction lift.	For lifts exceeding 20' of liquid, filling the chambers with liquid will prime the pump in most cases.
	Suction side air leakage or air in product.	Visually inspect all suction-side gaskets and pipe connections.
	Pumped fluid in air exhaust muffler.	Disassemble pump chambers. Inspect for diaphragm rupture or loose diaphragm plate assembly.
Pump Cycles Running Sluggish/Stalling, Flow Unsatisfactory	Over lubrication.	Set lubricator on lowest possible setting or remove. Units are designed for lube free operation.
	Icing.	Remove muffler screen, de-ice, and re-install. Install a point of use air drier.
	Clogged manifolds.	Clean manifolds to allow proper air flow
	Deadhead (system pressure meets or exceeds air supply pressure).	Increase the inlet air pressure to the pump. Pump is designed for 1:1 pressure ratio at zero flow. (Does not apply to high pressure 2:1 units).
	Cavitation on suction side.	Check suction (move pump closer to product).
	Lack of air (line size, PSI, CFM).	Check the air line size, length, compressor capacity.
	Excessive suction lift.	For lifts exceeding 20' of liquid, filling the chambers with liquid will prime the pump in most cases.
	Air supply pressure or volume exceeds system hd.	Decrease inlet air (press. and vol.) to the pump. Pump is cavitating the fluid by fast cycling.
	Undersized suction line.	Meet or exceed pump connections.
	Restrictive or undersized air line.	Install a larger air line and connection.
	Suction side air leakage or air in product.	Visually inspect all suction-side gaskets and pipe connections.
	Suction line is blocked.	Remove or flush obstruction. Check and clear all suction screens or strainers.
	Pumped fluid in air exhaust muffler.	Disassemble pump chambers. Inspect for diaphragm rupture or loose diaphragm plate assembly.
	Check valve obstructed.	Disassemble the wet end of the pump and manually dislodge obstruction in the check valve pocket.
	Check valve and/or seat is worn or needs adjusting.	Inspect check valves and seats for wear and proper setting. Replace if necessary.
Entrained air or vapor lock in chamber(s).	Purge chambers through tapped chamber vent plugs. Purging the chambers of air can be dangerous.	
Product Leaking Through Exhaust	Diaphragm failure, or diaphragm plates loose.	Replace diaphragms, check for damage and ensure diaphragm plates are tight.
	Diaphragm stretched around center hole or bolt holes.	Check for excessive inlet pressure or air pressure. Consult Chemical Resistance Chart for compatibility with products, cleaners, temperature limitations and lubrication.
Premature Diaphragm Failure	Cavitation.	Enlarge pipe diameter on suction side of pump.
	Excessive flooded suction pressure.	Move pump closer to product. Raise pump/place pump on top of tank to reduce inlet pressure. Install Back pressure device (Tech bulletin 41r). Add accumulation tank or pulsation dampener.
	Misapplication (chemical/physical incompatibility).	Consult Chemical Resistance Chart for compatibility with products, cleaners, temperature limitations and lubrication.
	Incorrect diaphragm plates or plates on backwards, installed incorrectly or worn.	Check Operating Manual to check for correct part and installation. Ensure outer plates have not been worn to a sharp edge.
Unbalanced Cycling	Excessive suction lift.	For lifts exceeding 20' of liquid, filling the chambers with liquid will prime the pump in most cases.
	Undersized suction line.	Meet or exceed pump connections.
	Pumped fluid in air exhaust muffler.	Disassemble pump chambers. Inspect for diaphragm rupture or loose diaphragm plate assembly.
	Suction side air leakage or air in product.	Visually inspect all suction-side gaskets and pipe connections.
	Check valve obstructed.	Disassemble the wet end of the pump and manually dislodge obstruction in the check valve pocket.
	Check valve and/or seat is worn or needs adjusting.	Inspect check valves and seats for wear and proper setting. Replace if necessary.
Entrained air or vapor lock in chamber(s).	Purge chambers through tapped chamber vent plugs.	

2: INSTAL & OP

For additional troubleshooting tips contact After Sales Support at service.warrenrupp@idexcorp.com or 419-524-8388

Composite Repair Parts Drawing

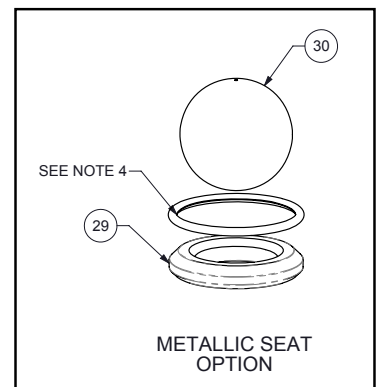
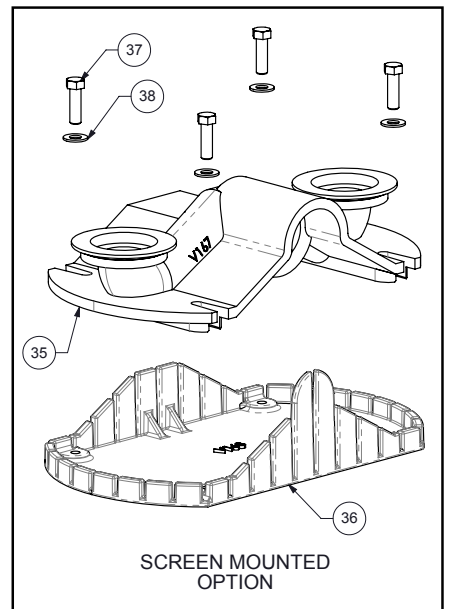
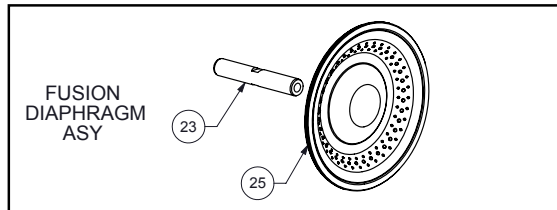
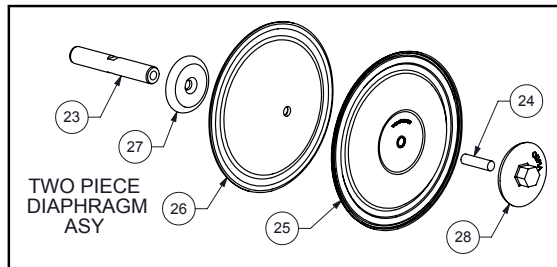
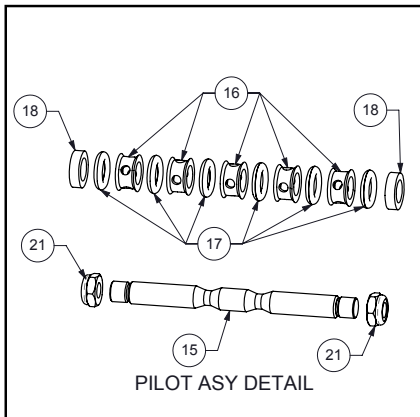

3: EXP VIEW

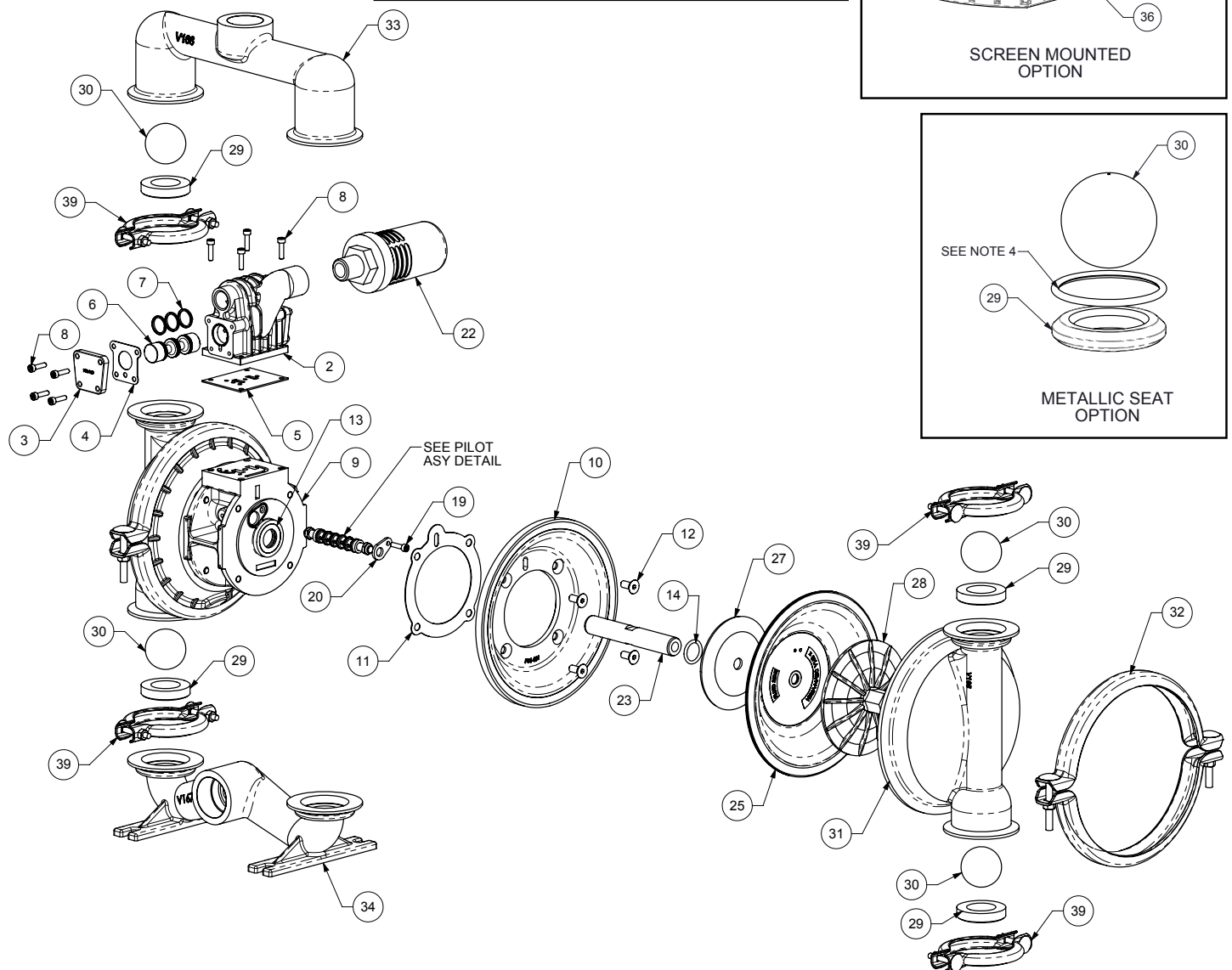

Composite Repair Parts List

Air Valve Assembly						
Item #	Qty.	Description	Part Number			
			Aluminum	Nickel Plated	PTFE Coated	
1	-	Valve Body Assembly (includes items 2-8)	P31-200	P31-200-NP	P31-200-TC	
2	1	Valve Body	P31-201	P31-201NP	P31-201TC	
3	2	End Cap	P50-300	P50-300NP	P50-300TC	
4	2	End Cap Gasket		P50-110		
5	1	Valve Body Gasket		P31-202		
6	1	Valve Spool		P50-104		
7	3	Glyde Ring Assembly		P50-104C		
8	12	Mounting Screws (8 included on item 1)		S1001		
Center Section Assembly						
Item #	Qty.	Description	Part Number			
			Aluminum	Nickel Plated	PTFE Coated	
9	1	Center Block Assembly (Includes item 13 & 14)	P31-400DC ASY	P31-401NP	P31-401TC	
10	2	Air Chamber	P31-101DC	P31-101NP	P31-101TC	
11	2	Air Chamber Gasket		P31-109		
12	8	Bolt		P31-404		
13	2	Bearing Sleeve		P31-403		
14	2	Main Shaft O-Ring		P24-403		
15	1	Pilot Shaft		P50-112		
16	5	Pilot Spacer		P24-106P		
17	6	Pilot O-Ring		P24-107		
18	2	Pilot Ring		2		
19	2	Screw		S1001		
20	2	Pilot Retainer		P50-109		
21	2	Stop Nut		P24-108		
22	1	Muffler		VTM-6		
Diaphragm Assembly / Elastomers						
Item #	Qty.	Description	Versa-Rugged	PTFE		
				Two Piece	Fusion	
23	1	Main Shaft	P31-103	P31-102	P31-103	
24	2	Main Shaft Stud	N/A	V221F	N/A	
25	2	Diaphragm (See Below Material Chart)	V163xx	V163TF	V163F	
26	2	Back-Up Diaphragm	N/A	V163TFB	N/A	
27	2	Inner Diaphragm Plate (See Note 2 Below)	V161C, V161CNP, V161CTC	V161TIC, V161TINP, V161TITC	N/A	
28	2	Outer Diaphragm Plate (See Note 1 Below)	VB161, SVB161, WVB161, HVB161	V161TO, SV161TO	N/A	
29	4	Valve Seat (See Below Material Chart)		V170xx		
30	4	Valve Ball (See Below Material Chart)		V171xx		
Wet End Assembly						
Item #	Qty.	Description	Part Number			
			Aluminum	Cast Iron	Stainless Steel	Hastelloy
31	2	Water Chamber	V165	WV165	SV165	HV165
32	2	Large Clamp Assembly		P31-110		SP31-110
33	1	Discharge Manifold	V166	WV166	SV166	HV166
		Discharge Manifold (BSP Option)	V166BSP	WV166BSP	SV166BSP	N/A
34	1	Suction Manifold (Footed Option)	V167F	WV167	SV167	HV167
		Suction Manifold (BSP Footed Option)	V167BSP	N/A	N/A	N/A
35	1	Suction Manifold (Screen Mount Option)	V167	N/A	N/A	N/A
36	1	Screen (Screen Mount Only)	V168	N/A	N/A	N/A
37	4	Bolt (Screen Mount Only)	V302G	N/A	N/A	N/A
38	4	Washer (Screen Mount Only)	V302GA	N/A	N/A	N/A
39	4	Small Clamp Assembly		V169		SV169
Elastomer Material Specifications						
Material	Versa-Rugged Diaphragm P/N	"Ball P/N"	Seat P/N			
Neoprene	V163N	V171N	V170N			
Nitrile	V163BN	V171BN	V170BN			
FKM	V163VT	V171VT	V170VT			
EPDM	V163ND	V171ND	V170ND			
PTFE	See item # 24	V171TF	N/A (use metallic seat)			
Santoprene	V163TPEXL	V171TPEXL	V170TPEXL			
Hytrel	V163TPEFG	V171TPEFG	V170TPEFG			
Geolast	V163G	V171G	V170G			
Aluminum	N/A	N/A	V170A (See Note 3)			
Carbon Steel	N/A	N/A	V170CS (See Note 3)			
Stainless Steel	N/A	V171SS	SV170 (See Note 3)			
Alloy C	N/A	N/A	HV170 (See Note 3)			

Notes:

- 1.) The outer diaphragm plate material is to match the water chamber material (Cast Iron pumps are to use Stainless outer diaphragm plate)
- 2.) The inner diaphragm plate material is to match the air chamber material
- 3.) This metallic seat material is to match the water chamber material. In addition to this seat, (4) o-rings are needed. (Ref Note 4)
- 4.) (4) V170T o-rings are only used with metallic fitted seats.
- 5.) V=Aluminum, SV=Stainless Steel, WV=Cast Iron, H=Hastelloy, TC=PTFE Coated, NP=Nickel Plated

Written Warranty

5 - YEAR Limited Product Warranty

Quality System ISO9001 Certified • Environmental Management Systems ISO14001 Certified

Versa-Matic warrants to the original end-use purchaser that no product sold by Versa-Matic that bears a Versa-Matic brand shall fail under normal use and service due to a defect in material or workmanship within five years from the date of shipment from Versa-Matic's factory.

~ See complete warranty at <http://www.versamatic.com/pdfs/VM%20Product%20Warranty.pdf> ~

DECLARATION OF CONFORMITY

DECLARATION DE CONFORMITE • DECLARACION DE CONFORMIDAD • ERKLÄRUNG BEZÜGLICH EINHALTUNG DER VORSCHRIFTEN
DICHIARAZIONE DI CONFORMITÀ • CONFORMITEITSVERKLARING • DEKLARATION OM ÖVERENSSTÄMMELSE
EF-OVERENSSTEMMELSESERKLÆRING • VAATIMUSTENMUKAISUUSVAKUUTUS • SAMSVARSERKLÄRING
DECLARAÇÃO DE CONFORMIDADE

MANUFACTURED BY:

FABRIQUE PAR:
FABRICADA POR:
HERGESTELLT VON:
FABBRICATO DA:
VERVAARDIGD DOOR:
TILLVERKAD AV:
FABRIKANT:
VALMISTAJA:
PRODUSENT:
FABRICANTE:

VERSA-MATIC®
Warren Rupp, Inc.
A Unit of IDEX Corporation
800 North Main Street
P.O. Box 1568
Mansfield, OH 44901-1568 USA

Tel: 419-526-7296
Fax: 419-526-7289



PUMP MODEL SERIES: E SERIES, V SERIES, VT SERIES, VSMA3, SPA15, RE SERIES AND U2 SERIES

This product complies with the following European Community Directives:

Ce produit est conforme aux directives de la Communauté européenne suivantes:

Este producto cumple con las siguientes Directrices de la Comunidad Europea:

Dieses produkt erfüllt die folgenden Vorschriften der Europäischen Gemeinschaft:

Questo prodotto è conforme alle seguenti direttive CEE:

Dir produkt voldoet aan de volgende EG-richtlijnen:

Denna produkt överensstämmer med följande EU direktiv:

Versa-Matic, Inc., erklærer herved som fabrikant, at ovennævnte produkt er i overensstemmelse med bestemmelserne i Direktive:

Tämä tuote täyttää seuraavien EC Direktiivien vaatimukset:

Dette produkt oppfyller kravene til følgende EC Direktiver:

Este produto está de acordo com as seguintes Directivas comunitárias:

2006/42/EC
on Machinery, according
to Annex VIII

This product has used the following harmonized standards to verify conformance:

Ce matériel est fabriqué selon les normes harmonisées suivantes, afin d' en garantir la conformité:

Este producto cumple con las siguientes directrices de la comunidad europea:

Dieses produkt ist nach folgenden harmonisierten standards gefertigt worden, die übereinstimmung wird bestätigt:

Questo prodotto ha utilizzato i seguenti standards per verificare la conformità:

De volgende geharmoniseerde normen werden gehanteerd om de conformiteit van dit produkt te garanderen:

För denna produkt har följande harmoniserande standarder använts för att bekräfta överensstämmelse:

Harmoniserede standarder, der er benyttet:

Tässä tuotteessa on sovellettu seuraavia yhdenmukaistettuja standardeja:

Dette produkt er produsert i overensstemmelse med følgende harmoniserte standarder:

Este produto utilizou os seguintes padrões harmonizados para verificar conformidade:

EN809:1998+
A1:2009

AUTHORIZED/ APPROVED BY:

Approuve par:
Aprobado por:
Genehmigt von:
approvato da:
Goedgekeurd door:
Underskrift:
Valtuutettuna:
Bemyndiget av:
Autorizado Por:

Dave Roseberry
Engineering Manager

DATE: August 10, 2011

FECHA:
DATUM:
DATA:
DATO:
PÄIVÄYS:



VMQR 044FM

04/19/2012 REV 07

4: WARRANTY