

CAST IRON WAFER CHECK VALVE MODEL - WCV1



FEATURES AND BENEFITS

- Features excellent retaining performance, high safety and reliability
- Low flow resistance
- Effective in preventing backflow of the medium, reducing water hammer.
- No maintenance required
- Two torsion springs exert pressure on the pair of disc which close the discs quickly and automatically.
- The quick close action prevents the medium from backflow and eliminates water hammer.
- Easy to install
- Can be installed both vertically or horizontally
- Larger sizes equipped with eye bolts to assist with lifting and installation.



ITEM	COMPONENT	MATERIAL	GRADE
1	Body	Cast Iron	AS1831
2	Seal	Nitrile	AS1646
3	Disc	Stainless Steel 316	ASTM351 CF8M
4	Stem	Stainless Steel 316	ASTM 276 304
5	Spring	Stainless Steel 316	ANSI 304

TECHICAL SPECIFICATION

Construction: Dual Plate Wafer Check Valve

Size: 50mm - 600mm

(Larger sizes available upon request)

Pressure Rating: PN16

Face to Face: ISO5752 Series 16

Flanging: Suits AS2129 Table E & D, AS4087 B5

Coating: 2 Pack Epoxy

Temperature Range: -10°C - 80°C

Pressure Testing: Shell— 24BAR

Seat—17.6 BAR

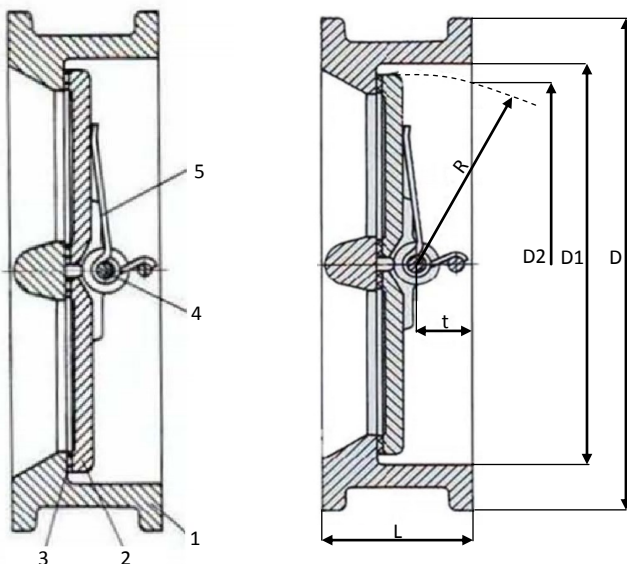

APPLICATIONS

Challenger Valves and Actuators are the **“Right Choice for Valves and Actuation”** when quality matters.

Servicing industries such as: Textile, Water Treatment, Irrigation, Energy & Light Industry

DIMENSIONS AND WEIGHTS							
Size	L	D	D1	D2	R	t	Weight Kg
50	43	107	65	43.3	50	29	1.5
65	48	127	80	60.2	65	30	2.4
80	64	142	94	66.4	80	38	3.6
100	64	162	117	90.8	52.8	27	5.7
125	70	192	145	116.9	65.7	30	7.3
150	74	218	170	144.6	78.6	31	9.0
200	89	273	224	198.2	104.4	33	17
250	114	328	265	233.7	127	50	26
300	114	376	310	283.9	148.3	43	42
350	127	438	360	332.9	172.4	45	55
400	140	489	410	381.0	197.4	52	75
450	152	555	450	419.9	217.8	58	107
500	152	594	505	467.8	241	58	111
600	178	690	624	572.8	295.4	73	172