

PROVIDING PURE, CLEAR, GREAT-TASTING WATER ON TAP.



Pristine Water

Puretec filter systems provide clear great tasting water removing chlorine, harmful chemicals, taste, odour, sediment, and on some models Giardia and Cryptosporidium cysts

Save Time & Money

Purified water is available at the touch of the tap - no lugging bottles and no running out. All at a fraction of the cost.

Do-it-Yourself Cartridges

Cartridges are designed to be changed yourself with ease. Saving technician call-out fees.

Easy Installation

The Filter kits come complete with all the required plumbing fittings for installation so the units are 'ready to go'.

Backup

Puretec group is a family owned Australian company since 1989. The Basic Puretec systems are covered by a 1 year warranty.



Customer Service: **1300 140 140**
Email: sales@puretec.com.au
Web: www.puretec.com.au

Customer Service: **0800 130 140**
Email: sales@puretec.co.nz
Web: www.puretec.co.nz

What's Inside

IL-UB Series Inline Undersink Filter System with Filter Tap	4
IL-TM Series Inline Undersink Water Filter System with 3-Way Tap	5
TW Series Twin Undersink Filter System	8
RU-194-4 Reverse Osmosis Undersink Filter System	9
WU Series Dual Whole House Filtration System	10
WU-UV Series Filtration & UV All-in-One Unit with Reversible Mounting	12
System Dimension Diagrams.....	14

Our dedication to manufacturing a wide range of leading edge products with seamless backup has ensured our water filtration products are of impeccable quality and are true to our tag line "perfecting water".

The Puretec range has been designed for the worldwide market from extensive market research and customer feedback. We know uncompromising quality and consistency along with innovation and technology is of utmost importance with water filtration - that's how we've ensured Puretec water is consistent and exact.

IL- UB

Inline Undersink Filter System with Filter Tap



FEATURES

- Designed for mains water.
- Compact design saves space.
- Mounts horizontally or vertically.
- Do-It-Yourself cartridge change out.
- Removes sediment, taste, odour & heavy metals.
- Designed for town and rural water supplies.

COMPLETE KIT INCLUDES:

- Installation Instructions
- All fittings for Standard Installation
- High Loop Faucet
- Filter Cartridge
- Pressure Limiting Valve

Model Number:	IL-UB
Faucet Model:	OT250
Replacement Cartridge:	IN149C
Micron Rating	1 micron
Flow Capacity	1.9 Litres Per Minute
Maximum Pressure	500 kPa
Maximum Temperature	38°C
Connection:	1/4" Quick Connect
Space Required:	350 mm x 120 mm
Warranty:	1 year



IL-TM10

Inline Undersink Water Filter System with 3-Way Tap



FEATURES

- Designed for mains water.
- Compact design saves space.
- Mounts horizontally or vertically.
- Do-It-Yourself cartridge change out.
- Removes sediment, taste, odour & heavy metals.
- Designed for town and rural water supplies

COMPLETE KIT INCLUDES:

- Installation Instructions
- All fittings for Standard Installation
- Stylish 3-Way Mixer Tap
- Pressure Limiting Valve

Model Number:	IL-TM10
Mixer Tap Model:	TM10
Replacement Cartridge:	IN149C
Micron Rating	1 micron
Flow Capacity	1.9 Litres Per Minute
Maximum Pressure	500 kPa
Maximum Temperature	38°C
Connection:	1/4" Quick Connect
Space Required:	350 mm x 120 mm
Warranty:	1 year



IL-TM20

Inline Undersink Water Filter System with 3-Way Tap



FEATURES

- Designed for mains water.
- Compact design saves space.
- Mounts horizontally or vertically.
- Do-It-Yourself cartridge change out.
- Removes sediment, taste, odour & heavy metals.
- Designed for town and rural water supplies

COMPLETE KIT INCLUDES:

- Installation Instructions
- All fittings for Standard Installation
- Stylish 3-Way Mixer Tap
- Pressure Limiting Valve

Model Number:	IL-TM20
Mixer Tap Model:	TM20
Replacement Cartridge:	IN149C
Micron Rating	1 micron
Flow Capacity	1.9 Litres Per Minute
Maximum Pressure	500 kPa
Maximum Temperature	38°C
Connection:	1/4" Quick Connect
Space Required:	350 mm x 120 mm
Warranty:	1 year



IL-TM30

Inline Undersink Water Filter System with 3-Way Tap



FEATURES

- Designed for mains water.
- Compact design saves space.
- Mounts horizontally or vertically.
- Do-It-Yourself cartridge change out.
- Removes sediment, taste, odour & heavy metals.
- Designed for town and rural water supplies

COMPLETE KIT INCLUDES:

- Installation Instructions
- All fittings for Standard Installation
- Stylish 3-Way Mixer Tap
- Pressure Limiting Valve

Model Number:	IL-TM20
Mixer Tap Model:	TM20
Replacement Cartridge:	IN149C
Micron Rating	1 micron
Flow Capacity	1.9 Litres Per Minute
Maximum Pressure	500 kPa
Maximum Temperature	38°C
Connection:	1/4" Quick Connect
Space Required:	350 mm x 120 mm
Warranty:	1 year



TW Series

Twin Undersink Filter System



FEATURES

- Designed for mains water.
- Dual stage for extra cartridge life & dirt capacity.
- Do-It-Yourself cartridge change out.
- Removes sediment, taste, odour, chlorine, giardia and cryptosporidium cysts.
- Very economical filter replacement cost.

COMPLETE KIT INCLUDES:

- Installation Instructions
- All fittings for Standard Installation
- OT250 High Loop Faucet
- Pressure Limiting Valve (TW1-PL)

Model Number:	TW1	TW1-PL
Sediment Cartridge:	MB051	MB051
Taste & Odour Cartridge:	EC951	EC951
Micron Rating:	0.5 micron	0.5 micron
Flow Capacity:	7 Lpm	7 Lpm
Maximum Pressure:	500 kPa	500 kPa
Maximum Temperature:	45 °C	45°C
Connection:	1/4" QC	1/4" QC
Space Required:	390 x 240 x 120 mm	
Pressure Limiting Valve:	No	Yes
Warranty:	1 year	1 year



RU-194-4

Reverse Osmosis Undersink Filter System



FEATURES

- Designed for mains water.
- Removes pp to 98% of all impurities including Fluoride.
- Storage tank for speedy pure water delivery.
- 4 stage filtration process.
- Latest reverse osmosis filtration process.

Model Number:	RU194-4
Micron Rating:	0.0005 micron
Capacity:	283 Lpd
Tank Capacity:	7 Litres
Tank Refill Rate:	0.19 Lpm
Tank Delivery Flow Rate:	4 Lpm
Maximum Pressure:	500 kPa
Maximum Temperature:	38°C
Connection:	15mm (1/2") cold water line
Warranty:	1 year

COMPLETE KIT INCLUDES:

- Installation Instructions
- All fittings for Standard Installation
- OT250 High Loop Faucet
- Filter Cartridges
- Pressure Limiting Valve
- 7 Litre Storage Tank



WU Series 10"

Dual Whole House Filtration System



FEATURES

- Chlorine and dirt reduction.
- Taste and odour reduction.
- No power required.
- Easy to install and low maintenance.

COMPLETE KIT INCLUDES:

- Installation Instructions
- All fittings for Standard Installation
- Dual 10" Housings & Bracket
- Filter Cartridges

Model Number:	WU10-25R	WU10-25M	WU10-40R	WU10-40M
Water Supply:	Rainwater	Mains Water	Rainwater	Mains Water
Sediment Cartridge:	PP05LD1	MB05LD1	PP05LD1	MB05LD1
Taste & Odour Cartridge:	ML10LD1-DP	EC10LD1	ML10LD1-DP	EC10LD1
Micron Rating:	5 micron			
Flow Capacity:	60 Lpm	30 Lpm	60 Lpm	30 Lpm
Max Pressure:	520 kPa			
Max Temperature:	52°C			
Connection:	1" BSP	1" BSP	1 ½" BSP	1 ½" BSP
Size:	390 x 465 x 200 mm			
Warranty:	1 year			



WU Series 20"

Dual Whole House Filtration System



FEATURES

- Designed for mains water.
- Chlorine and dirt reduction.
- Taste and odour reduction.
- No power required.
- Easy to install and low maintenance.

COMPLETE KIT INCLUDES:

- Installation Instructions
- All fittings for Standard Installation
- Dual 20" Housings & Bracket
- Filter Cartridges

Model Number:	WU20-25R	WU20-25M	WU20-40R	WU20-40M
Water Supply:	Rainwater	Mains Water	Rainwater	Mains Water
Sediment Cartridge:	PP05LD2	MB05LD2	PP05LD2	MB05LD2
Taste & Odour Cartridge:	ML10LD2-DP	EC10LD2	ML10LD2-DP	EC10LD2
Micron Rating:	5 micron			
Flow Capacity:	60 Lpm	30 Lpm	60 Lpm	30 Lpm
Max Pressure:	520 kPa			
Max Temperature:	52°C			
Connection:	1" BSP	1" BSP	1 ½" BSP	1 ½" BSP
Size:	390 x 730 x 200 mm			
Warranty:	1 year			



WU-UV Series 10"

Whole House Filtration & Ultraviolet All-in-One Unit with Reversible Mounting



FEATURES

- Designed for rainwater
- Kills 99.9% of bacteria.
- Reversible mounting frame for easy installation.
- Lamp count-down timer & failure alarm.
- Turns your tank water into pure & safe water at every tap.

COMPLETE KIT INCLUDES:

- Installation Instructions
- 10" Dual Housing Assembly
- Radfire® UV Filter
- Filter Cartridges
- Housing Spanner

Model Number:	WU-UV100 (NZ)	WU-UV150 (AU)
Stage 1 Cartridge:	PP2OLD1	PPO5LD1
Stage 2 Cartridge:	MB01LD1	ML10LD1-DP
UV Lamp:	RL6	RL6
Quartz Sleeve:	RQS6	RQS6
Micron Rating:	1 micron	5 micron
Max Flow Rate:	60 Lpm	60 Lpm
Max Pressure:	520 kPa	520 kPa
Max Temperature:	52°C	52°C
Connection:	1" BSP	1" BSP
Size:	555 x 583 x 187 mm	555 x 583 x 187 mm
Warranty:	1 year	1 year

UV DOSAGES

Flow rate @40mJ/cm ²	54 Lpm
Flow rate @30mJ/cm ²	70 Lpm*
Flow rate @16mJ/cm ²	130 Lpm

*Industry standard for drinking water



WU-UV Series 20"

Whole House Filtration & Ultraviolet All-in-One Unit
with Reversible Mounting



FEATURES

- Designed for rainwater
- Kills 99.9% of bacteria.
- Reversible mounting frame for easy installation.
- Lamp count-down timer & failure alarm.
- Turns your tank water into pure & safe water at every tap.

COMPLETE KIT INCLUDES:

- Installation Instructions
- 20" Dual Housing Assembly
- Radfire® UV Filter
- Filter Cartridges
- Housing Spanner

Model Number:	WU-UV200 (NZ)	WU-UV250 (AU)
Stage 1 Cartridge:	PP20LD2	PP05LD2
Stage 2 Cartridge:	MB01LD2	ML10LD2-DP
UV Lamp:	RL6	RL6
Quartz Sleeve:	RQS6	RQS6
Micron Rating:	1 micron	5 micron
Max Flow Rate:	110 Lpm	110 Lpm
Max Pressure:	520 kPa	520 kPa
Max Temperature:	52°C	52°C
Connection:	1" BSP	1" BSP
Size:	555 x 583 x 187 mm	555 x 583 x 187 mm
Warranty:	1 year	1 year

UV DOSAGES

Flow rate @40mJ/cm ²	54 Lpm
Flow rate @30mJ/cm ²	70 Lpm*
Flow rate @16mJ/cm ²	130 Lpm

*Industry standard for drinking water



Dimensions

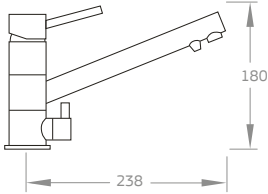

IL-TM10 TAP

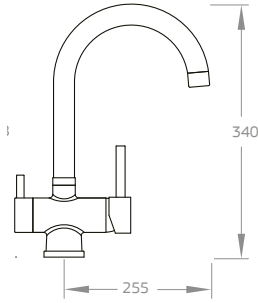

IL-TM20 TAP

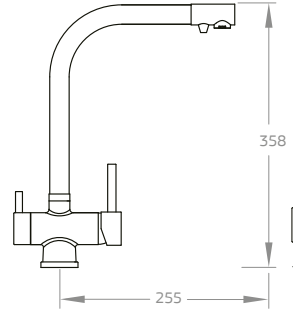

IL-TM30 TAP

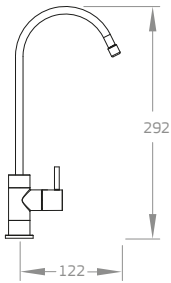

OT250

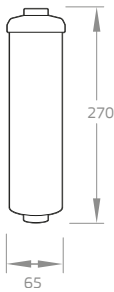

IN149C

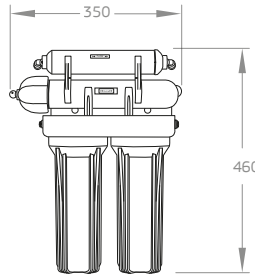

RU194-4

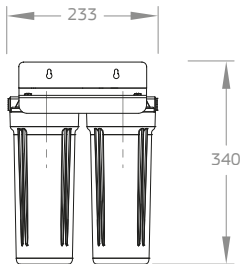
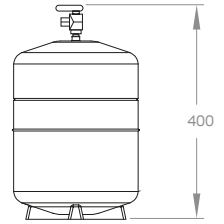

TW SERIES

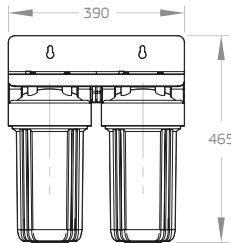

WU 10" SERIES

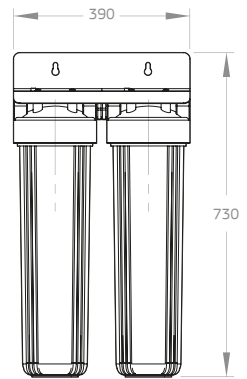

WU 20" SERIES

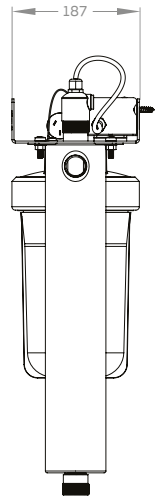
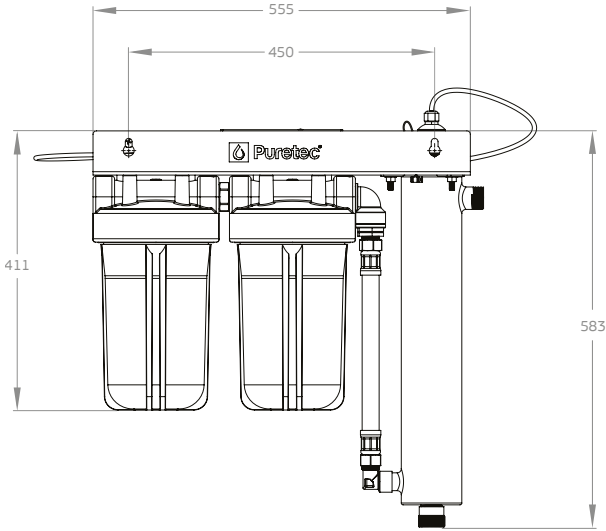

WU-UV 10" SERIES

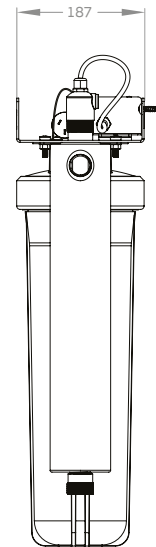
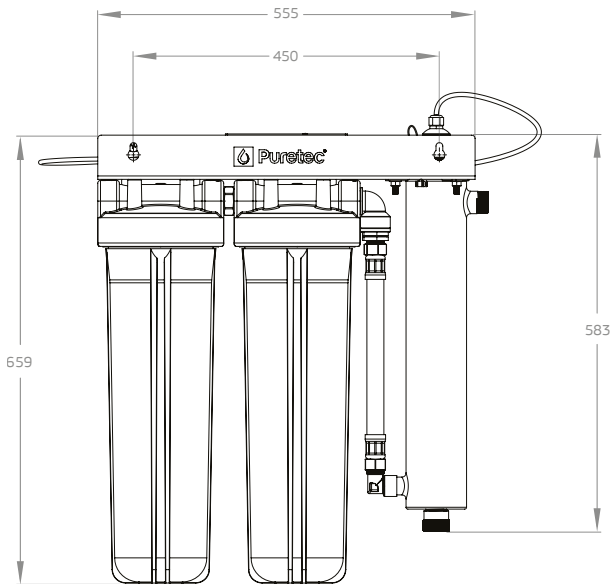

WU-UV 20" SERIES

The effectiveness of any water treatment system is affected by variances in incoming water quality. Do not use with unknown or contaminated water that does not fit the parameters of the system/product as specified by Puretec, for further assistance, contact the Puretec Customer Service Helpline on 1300 140 140 (AU) or 0800 130 140 (NZ).

This catalogue renders all previous catalogues invalid. No claims can be made based on the specifications and images in this catalogue. The design, technology, colours, features and prices are subject to change. This catalogue and all its contents are copyright protected. All rights are reserved, particularly alteration, translation and reproduction using electronic systems. Whilst every endeavour is made to ensure accuracy, no responsibility is taken for any errors or omissions in detail. This brochure contains information which is general in nature, you should seek professional advice for your own application. Important Note: Sales of products are subject to our Terms and Conditions which are available upon request. Warning: For correct operation of appliances it is essential to observe manufacturer's instructions.

This catalogue contains various filter systems and cartridges designed for different applications. Puretec dealers can provide you with advice to suit your needs. Please call our Customer Care Team for assistance. Micron ratings are nominal.

Copyright © Puretec Pty Ltd 2022.



Customer Service: **1300 140 140**
Email: sales@puretec.com.au
Web: www.puretec.com.au

Customer Service: **0800 130 140**
Email: sales@puretec.co.nz
Web: www.puretec.co.nz

