



A **valmont** COMPANY



HR PRODUCTS COMMERCIAL SERIES VALVE BOX

hrproducts.com.au



V1_0324

COMMERCIAL SERIES VALVE BOX

Protects in-ground irrigation valves, functions as a durable enclosure that provides easy access to valves for maintenance.
Used in turf applications to house either single valves, multiple valves, or other subsurface components of an irrigation system.

Product Features

- Moulded from 100% recycled High Density Polyethylene Materials (HDPE)
- 100% Australian Made
- Light Weight robust construction for long life and strong performance
- NEW Plastic Locking Bolt - no special key is needed (a standard set of pliers is all that is required)
- Optional Plug instead of Locking Bolt - if lockable box is not required
- Reinforced Side Ridges - for long life and strong performance
- NEW Improved Non Slip Surface Pattern - meets AS 4586 Wet Slip resistance rating (NATA Approved Testing Facility)
- Broad Base Version - for better in-ground surface area contact and stability in lighter compacted soil environments
- Metal Plate Option - can be fitted to underside of lid for easy location if valve box is buried
- Personalised customer detail option / special application marking & colouring (available on request)
- Reclaimed water detail / option - Entire box and lid in purple with optional extra customer detail upon request
- Chain connection fixing points on the underside of the lid and box to secure them together if required (chain not supplied)
- The 12" Valve box is interlockable when placed together (base to base) for deeper installation when required
- Suitable for general light commercial applications*

DESCRIPTION	ORDER CODE
Commercial Series Valve Box - 12" Standard Base	HR1419-12VBOLN
Commercial Series Valve Box - 12" Broad Base	HR1419-12VBOLNBB
Commercial Series Valve Box - 8" Standard Base	HR1419-8VBOLN
Commercial Series Valve Box - 6" Standard Base	HR1419-6VBOLN
Commercial Series Valve Box Overlay Lid for HR1419-XXVBOLN models	HR1419OLN
COMING SOON	
Commercial Series Valve Box - 12" Standard Base Reclaimed Water	HR1419-12VBOLNRW
Commercial Series Valve Box - 8" Standard Base Reclaimed Water	HR1419-8VBOLNRW
Commercial Series Valve Box - 6" Standard Base Reclaimed Water	HR1419-6VBOLNRW
Commercial Series Valve Box - 12" Standard Base Water Meter Lid	HR1419-12VBOLNWM
Commercial Series Valve Box - 8" Standard Base Water Meter Lid	HR1419-8VBOLNWM
Commercial Series Valve Box - 6" Standard Base Water Meter Lid	HR1419-6VBOLNWM

* Note: Please consult your local authority for load rating requirements for sites with heavy vehicular traffic site access. A higher graded product may be required.

VALVE BOX FEATURES

Chain Connection Fixing Points - keeps the lid connected to the valve box

(image shows optional metal plate for easy valve box location)

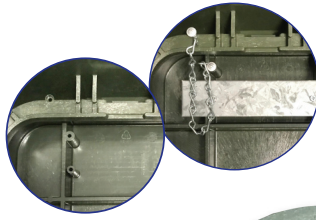

NEW Improved Non Slip Surface Pattern - meets AS 4586 Wet Slip resistance rating (NATA Approved Testing Facility)

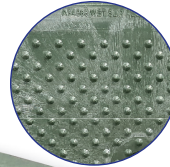

NEW Plastic Locking Bolt - no special key is needed (a standard set of pliers is all that is required)

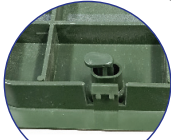

Lock Mechanism under lid

Reinforced Side Ridges - for long life and strong performance

Manufactured from - Recycled High Density Polyethylene Materials (HDPE)



Lid Removal Access Slot - makes lid removal easier with this special design access slot

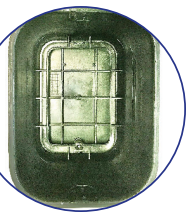

Old HR Commercial Valve Box

VS

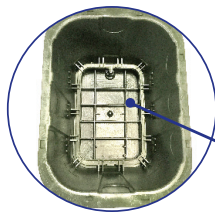

New HR Commercial Valve Box

Standard Base Version - smarter design large base footprint for extra in-ground stability

Base Lip Width: 32mm x 22mm

Base Lip Width

Broad Base Version - for better in-ground surface area contact and stability in lighter compacted soil environments

Base Lip Width: 50mm x 50mm



100% Australian Made

Extra Ribbing and a larger base footprint gives the **NEW HR Commercial Valve box** extra strength and stability

EXTERNAL DIMENSIONS (MM)					INTERNAL DIMENSIONS (MM)		
TOP LENGTH	TOP WIDTH	HEIGHT	BOTTOM LENGTH	BOTTOM WIDTH	CLEAR ACCESS TOP OPENING	INTERNAL BASE OPENING	

HR MANUFACTURED COMMERCIAL VALVE BOX

HR1419-12VBOLN - 12" Standard Model	435	302	315	575	417	355 x 255	490 X 355
HR1419-12VBOLNBB - 12" Broad Base	435	302	315	610	473	355 x 255	490 x 355
HR1419-8VBOLN - 8" Standard Model	435	302	220	555	400	355 x 255	470 x 335
HR1419-6VBOLN - 6" Standard Model	435	302	180	545	390	355 x 255	463 x 325

VALVE BOX DIMENSIONS

HR1419-6VBOLN - 6" Standard Model

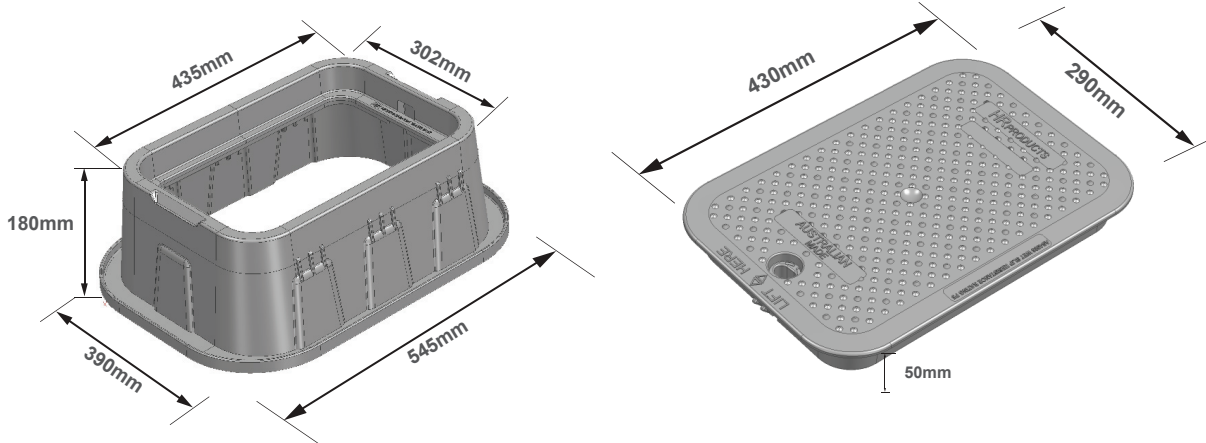

HR1419-8VBOLN - 8" Standard Model

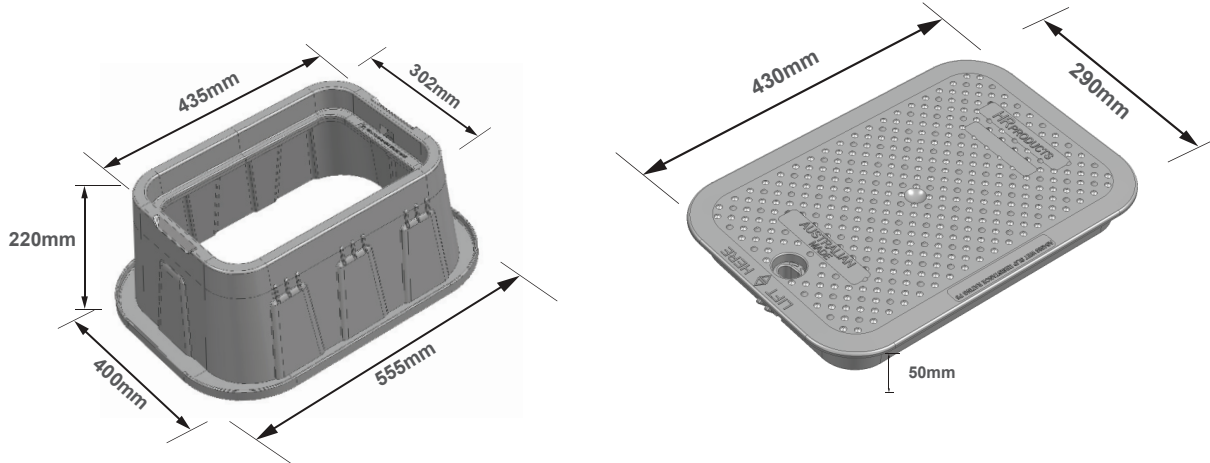

HR1419-12VBOLN - 12" Standard Model

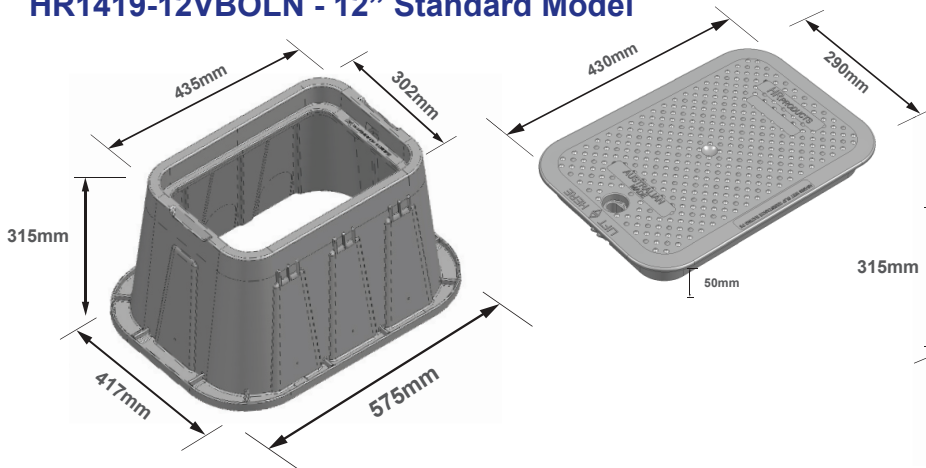

HR1419-12VBOLBB - 12" Broad Base Model

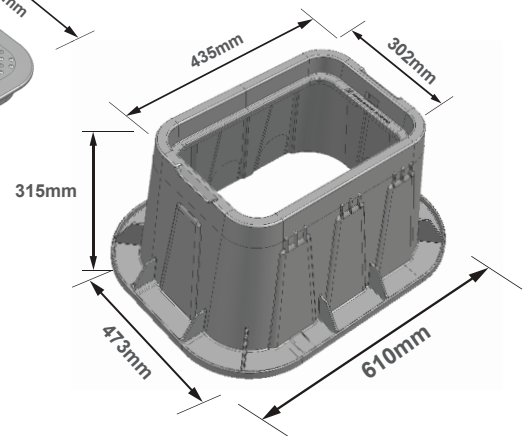

MANUFACTURERS IMPORTERS & DISTRIBUTORS
OF QUALITY IRRIGATION EQUIPMENT



A valmont COMPANY

PERTH
PH: 08 9484 6500
FAX: 08 9455 1680
hrsales@hrproducts.com.au

SYDNEY
PH: 02 9616 1300
FAX: 02 9725 5283
infonsw@hrproducts.com.au

MELBOURNE
PH: 03 8458 7400
FAX: 03 9457 7400
infovic@hrproducts.com.au

BRISBANE
PH: 07 3080 6200
FAX: 07 3806 0533
infoqld@hrproducts.com.au

ADELAIDE
PH: 08 8408 7200
FAX: 08 8341 0707
infosa@hrproducts.com.au

hrproducts.com.au

V1_0324