

PUMP CONTROL
**OWNER'S
OPERATION
MANUAL**

Rain/Mains Water Controller
Installation and Operating Instructions

MODEL: FPC-12725

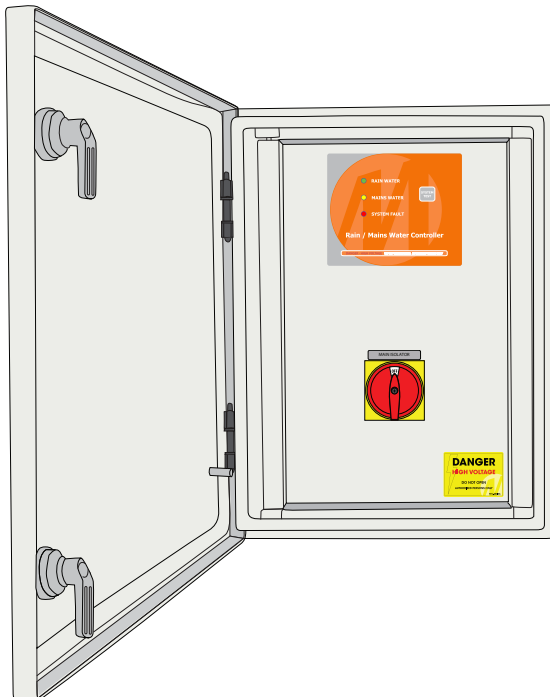

WELCOME TO LIQUID LEVEL CONTROL

Congratulations on the purchase of this product.

Your Liquid Level Control product reflects the superior quality and attention to detail in design, engineering and manufacturing that has distinguished MATElec Products for decades. The controller incorporates the very latest in micro-processor technology, ensuring you, the owner/operator many years of functional, reliable and 'user friendly' operation.

Please read this manual prior to installation and operation of the controller.

CONTENTS

SAFETY	2	NOTES	6
INSTALLATION	3	CIRCUIT DIAGRAM	7
Mounting			
Connection			
GETTING STARTED	4	AT A GLANCE	8
Operations		Indicators	
Features		Push Buttons	

WARNING: All electrical connections must be carried out by a suitably qualified and registered electrician

SAFETY

- Prior to Installation, ensure power supply is isolated.
- Power supply must be Circuit Breaker Protected. (Qualified Electrician to determine appropriate amp rating.)
- Electrical connection to the panel must be carried out in accordance with 'Connection Instructions', see page 3.
- Addition or modifications to the control panel are not permitted and will void warranty.
- The controller is not intended for use by children or infirm persons without supervision.
- Repairs to the Controller must only be carried out by a suitably qualified Electrician

INSTALLATION

MOUNTING

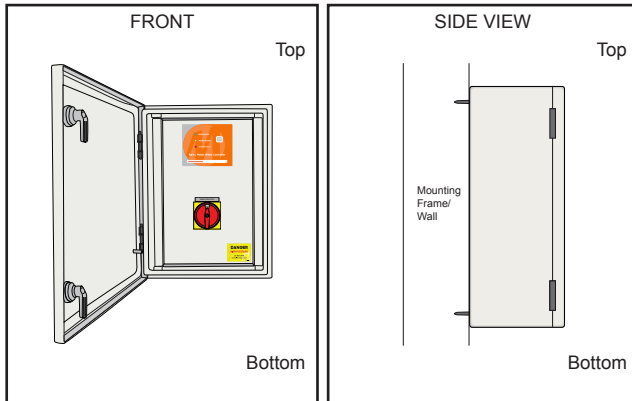

1. Controller enclosure must be mounted in a vertical position.
2. Ensure mounting method does not compromise enclosure weather proof rating.
3. Ensure access to main isolator is not restricted.
4. Ensure cables/conduits entering the panel have mechanical protection and that the penetrations are sealed and do not compromise the weather proof rating of the enclosure.

CONNECTION

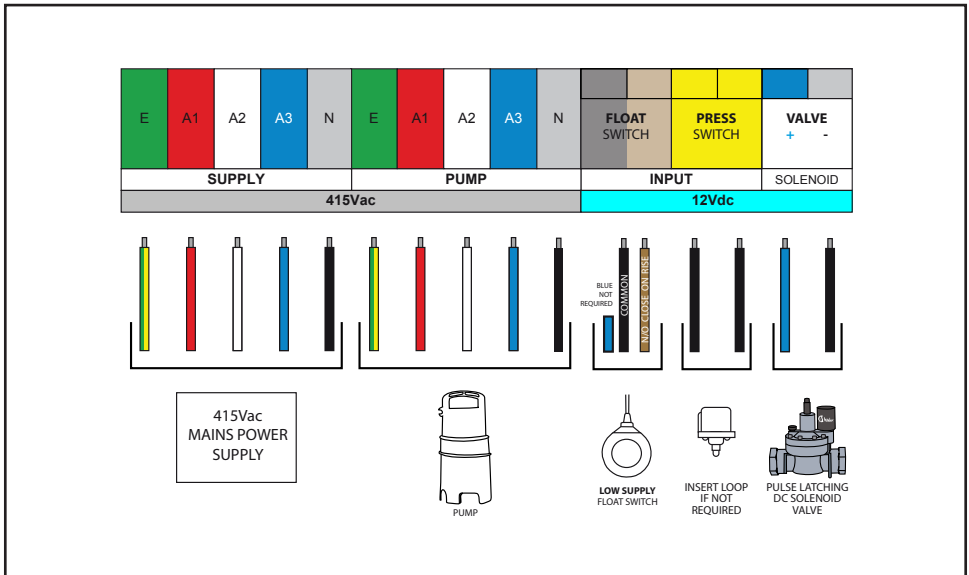

Note: Controller must be earthed and all electrical connections must be carried out by a suitably qualified Electrician.

GETTING STARTED

OPERATIONS

The unique MATElec Rain/Mains Water Controller is designed to provide a continuous supply of water for a variety of uses, whilst prioritising and maximising the usage of Rain Water.

The system comprises a Controller, a unique Valve and a Liquid Level Switch. The controller not only monitors the level of stored Rain Water, switching the valve accordingly, but also provides a switched output for the control of power to a pressure pumping system

If Rain Water becomes available, the valve through which Mains Water is being supplied, is automatically pulsed closed by the controller, and at the same time, the 240Vac pump output contacts are energised.

In the event of either 'Rain Water Depletion', 'Prime Loss' (if set up), 'Power Failure' or 'Pump Failure' the controller will immediately pulse the valve open, and de-energise the pump output contacts.

The controller has a 'System Test' function which, if initiated, changes the status of the system to enable the operator to check valve and pump function at the press of a button. This test button doubles as a Reset Button to enable the operator to clear faults without having to enter the live voltage area of the enclosure.

This product is ideally setup for Industrial and Commercial applications such as playing fields, golf courses and large commercial properties with multiple toilets, where a 'high flow' system is required. The controller is suited to an outdoor installation, and is housed in a weatherproof lockable metal enclosure.

FEATURES

- Unlimited pump options above ground or submersible
- Compatible with an entire range of high flow, low "head loss" valves
- No pressure reducing valves
- No continuously actuated solenoid valves
- Test Button - Provides change of system status, including pump and valve switching
- Indicator Lights provide 'power', 'valve' and 'fault' status information
- Pump protection feature - If Rain Water is depleted, switching of pump output isolates power to pressure pump system
- Controller can be situated up to 50m from storage tank
- Ideal for Industrial, Commercial and/or Domestic applications

SCHEMATIC

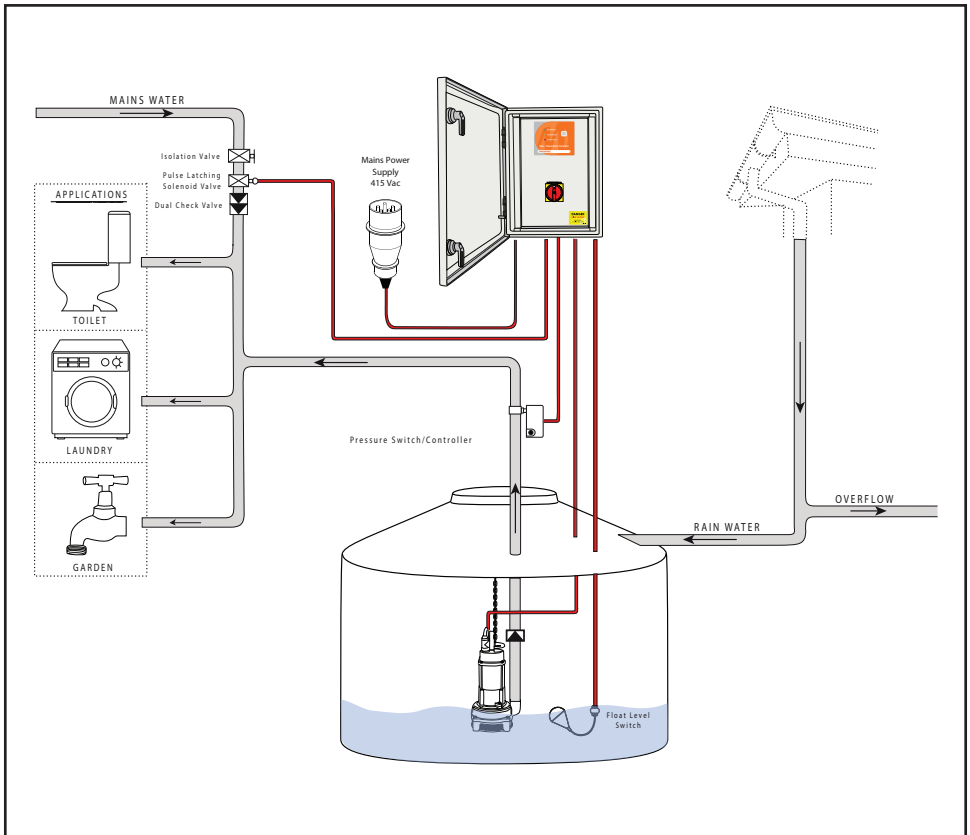

CIRCUIT DIAGRAM

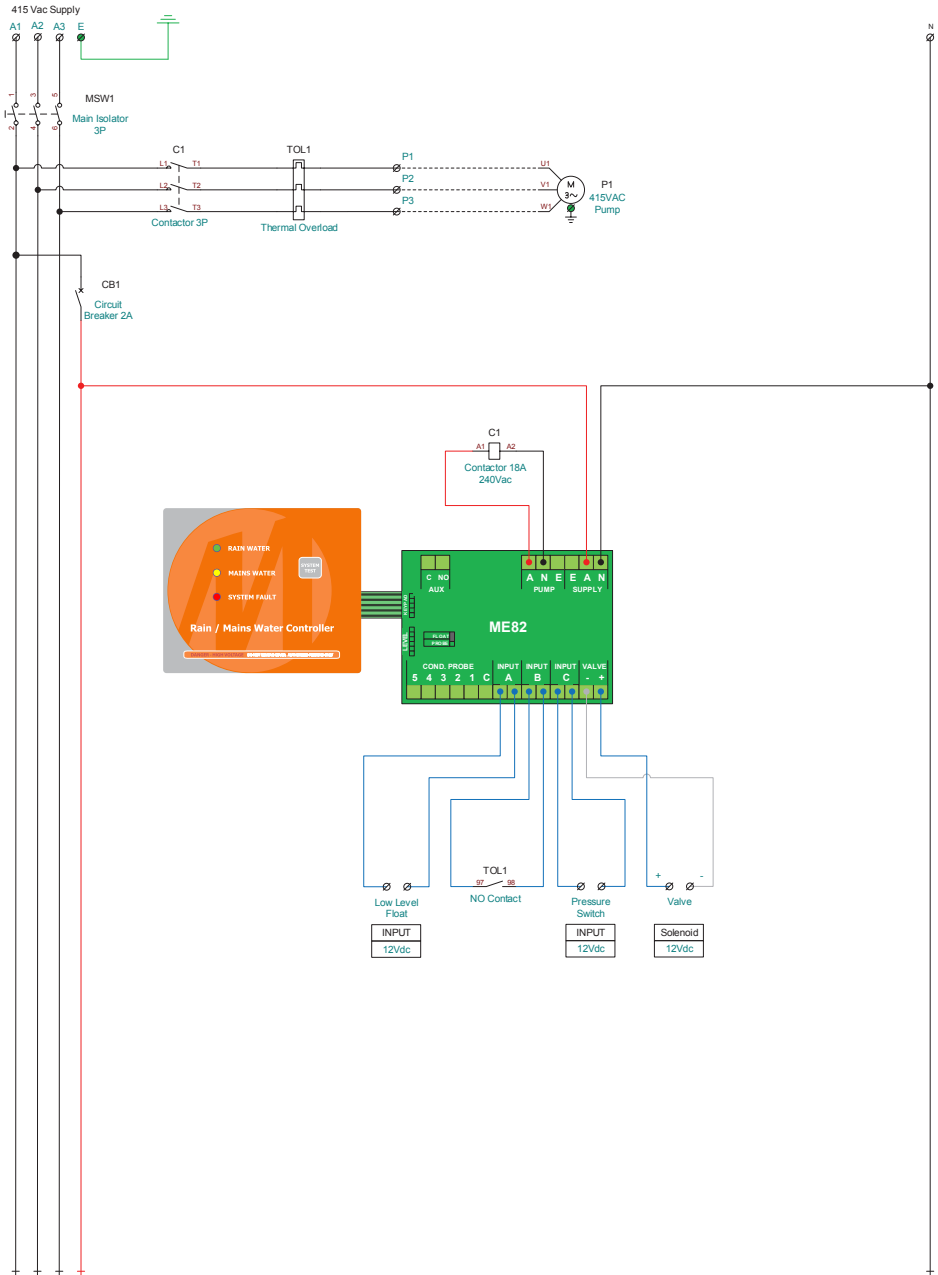

AT A GLANCE

A quick reference to the Rain/ Mains Water Controller's Keypad Button and Indicators functions and meanings.

NOTE: A light 'On' means Power is 'On'.

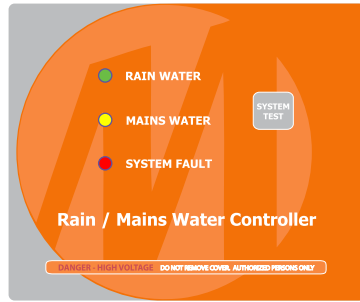

KEYPAD

INDICATORS

 RAIN WATER

ON STEADY
Rain/Tank Water is in use
FLASHING
The Pump is Running

 MAINS WATER

ON STEADY
Mains/Town Water is in use

 SYSTEM FAULT

ON STEADY
Either a Pump (overload) or
a Prime Loss (if setup) Fault
has occurred

PUSH BUTTONS

 SYSTEM TEST

Press to reset fault or momentary
SYSTEM change valve state

DISTRIBUTED BY:

INSTALLATION DATE:

SERIAL NUMBER:

MANUFACTURED BY MATElec AUSTRALIA

EMAIL: info@matelecaustralia.com.au

MATElec reserves the right to alter technical specifications without notice.