

SMB20/A/10HME03S15/M2

Company	APT Water	Customer	Date	12/05/2023
Contact	Andrew Dean	Contact	Item no.	
Phone number	08 6143 1000	Phone number	Project	
Email	andrew@aptwater.com.au	Email	Project no.	

Operating data

1	Pumpe type	Single head pump	Fluid	Water, pure
2	No. of pumps / Reserve	1 / 0	Operating temperature t A	°C 4
3	Nominal flow	m ³ /h 0	pH-value at t A	7
4	Nominal head	m 0	Density at t A	kg/dm ³ 1
5	Static head	m 0	Kin. viscosity at t A	mm ² /s 1.569
6	Inlet pressure	bar 0.098	Vapor pressure at t A	bar 0.0083
7	Environmental temperature	°C 20	Solids	0
8	Available system NPSH	m 0	Altitude	m 1000

Pump data

9	Pump designation		Impeller Ø	Max.	mm	
10	SMB20/A/10HME03S15/M2			designed	mm	
11	Design			Min.	mm	
12	Make			Nominal	m ³ /h	()
13			Flow	Max-	m ³ /h	33.9
14	Speed	1/min 2900		Min-	m ³ /h	
15				Nominal	m	
16	Max. working pressure	bar 5.2	Head	at Qmax	m	17.6
17	Head H(Q=0)	m 53		at Qmin	m	52.6
18	Weight	kg On demand	Shaft power		kW	()
19	Weight data include external package		Max. shaft power		kW	
20			Efficiency		%	
21			NPSH 3%		m	

Materials

22		Booster		Motor data		
23	Manifolds	AISI 304	Manufacturer	Lowara	Electric voltage	240 V
24	On-off valves	Nickel-plated brass	Specific design	Single phase e-SM motor (SMB)		
25	Non-return valves	Brass	Type	ESM80/115 HM	Electric current	4.43 A
26	Pressure switches	Galvanized steel/AISI 301	Rated power	1.5 kW	Degree of protection	IP 55
27	Pressure transmitters	AISI 304	Speed	3600 1/min	Insulation class	B
28	Caps/plugs/flanges	AISI 304 / 316	Frame size	80		RAL 5010
29	Fittings	AISI 304 / 316	Weight	0 kg		
30	BRACKET	Galvanized/painted steel				
31	Base	Painted steel				
32						

Standard options

33	Non return valve position		Non return valve in delivery side
34	Set certificate	/A	WRAS, ACS set certificate
35	Material Combination		Standard materials combination
36	Pump Test		Set without certified pumps
37	High pressure protection		Without high pressure protection on delivery
38	Turned Delivery Manifold		Standard
39	Oversize Piping		Standard manifold
40	Control panel		Standard
41	Protection against Dry running		Without protection against dry running
42	Control Devices Oversized		Standard
43	Delivery side		Standard delivery
44	Eintritt		Standard suction
45	Pressure transmitter		Standard
46	Control Panel Position		Standard position
47	Electric Pump Special Seals		Standard
48	Non-return Valve		Standard non-return valve

SMB20/A/10HME03S15/M2

Company	APT Water	Customer	Date	12/05/2023
Contact	Andrew Dean	Contact	Item no.	
Phone number	08 6143 1000	Phone number	Project	
Email	andrew@aptwater.com.au	Email	Project no.	
Operating Data Specification		Hydraulic data (duty point)		Impeller design
Flow	0 m ³ /h	Flow	Impeller R	0 mm
Head	0 m	Head	Frequency	50 Hz
Static head	0 m		Speed	2900 1/min

Power datas referred to:
 Water, pure [100%] ; 4°C; 1kg/dm³; 1.57mm²/s
 Performance according to ISO 9906:2012 – Grade 3B

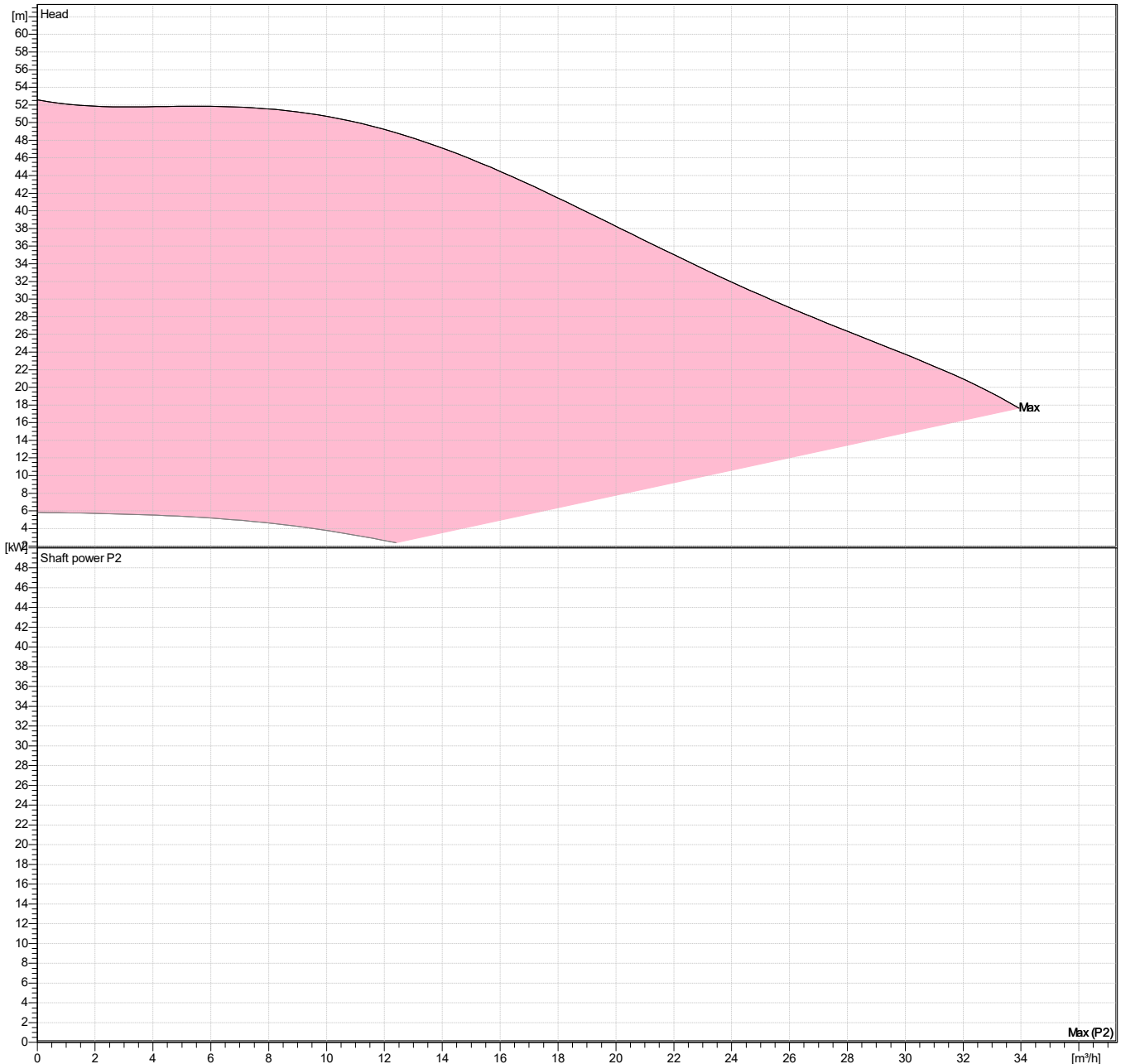

SMB20/A/10HME03S15/M2

Company	APT Water	Customer	Date	12/05/2023
Contact	Andrew Dean	Contact	Item no.	
Phone number	08 6143 1000	Phone number	Project	
Email	andrew@aptwater.com.au	Email	Project no.	

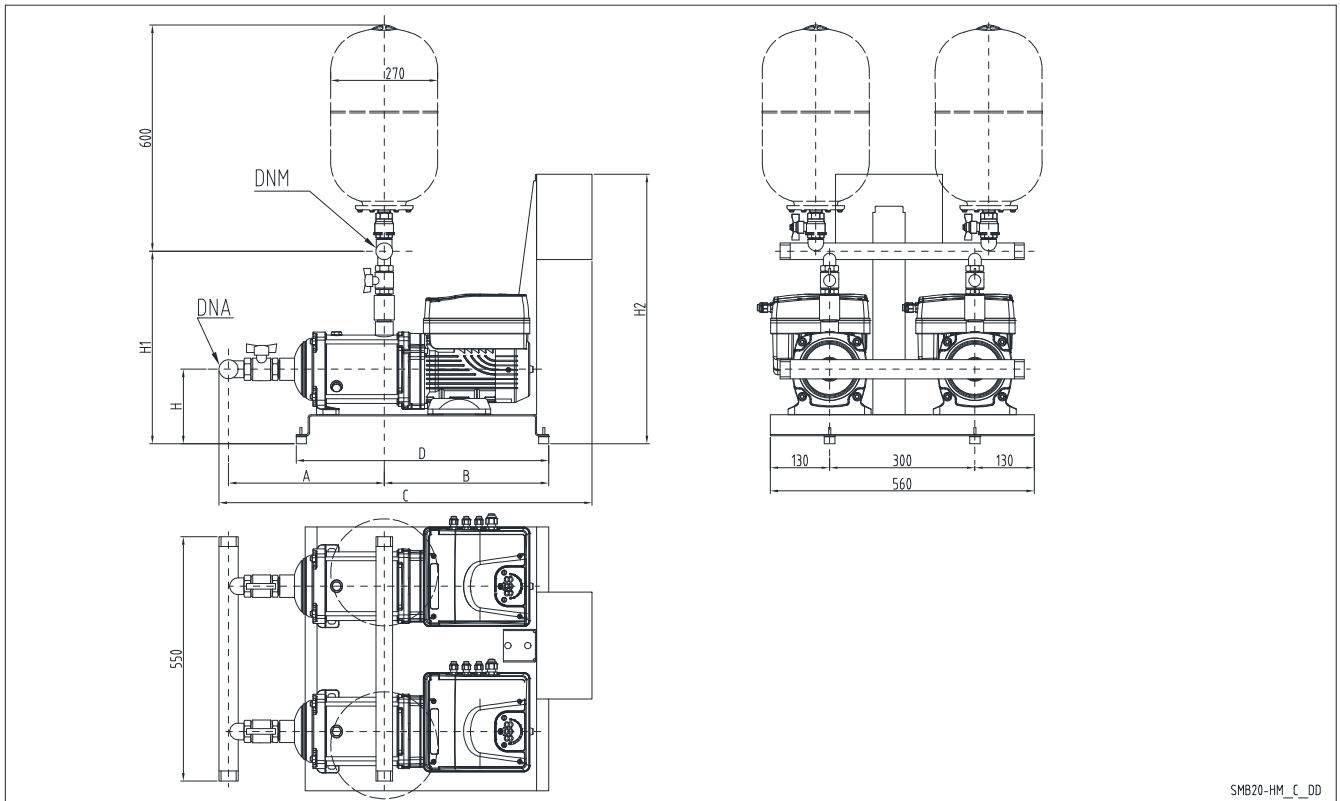

PLEASE NOTE:

Dimensions

mm

A	301				Weight (Include external package) On demand
B	350				
C	749				
D	590				
DNA	R 2"1/2				
DNM	R 2"1/2				
H	205				
H1	611				
H2	720				